

General Catalogue

2020 — 2021

The world of heating and cooling is changing with Panasonic

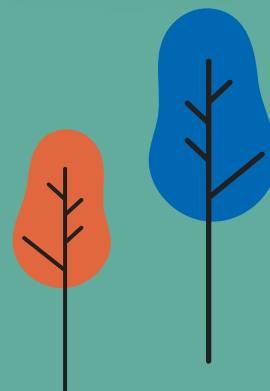
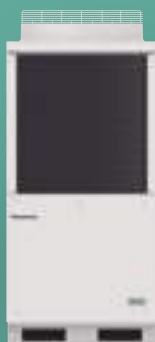

AQUAREA

Aquarea is a ground breaking low energy system for heating and domestic hot water production: delivering outstanding performance, even at extreme outdoor temperatures.

Aquarea J generation R32.

Aquarea is now available in R32, making Aquarea excellent choice for those who really care the environment. Aquarea J Series, the new generation designed for R32 refrigerant.



Aquarea Service Cloud for professionals.

Aquarea Service Cloud will activate remote maintenance service while end user is controlling and monitoring its heating and DHW remotely.



New Aquarea All in One Compact.

The Aquarea All in One Compact unit is the ultimate space-saving solution. Its 598 x 600 mm footprint, standard size of other big appliances, reduces the space required for the installation.



New residential heat recovery solution.

Ventilation systems with heat recovery offer users a high degree of living comfort thanks to temperature controlled and clean air. Heat recovery units in combination with Aquarea heat pump are the ideal solution.

DOMESTIC

Panasonic has developed a range of domestic products designed for you and your clients.

Cleaning the air we breathe.

Panasonic systems are equipping different technologies to clean the air. Anti allergy nanoe™ X and PM2,5 filters are some examples to take care of the air we breathe.



Easy installation and servicing.

Intelligently designed for quick and simple installation, the new models are lighter, smaller and stronger than ever.



New super-compact units.

The new super-compact wall-mounted units measure a mere 779 mm, ideal for installations in narrow spaces or above the door. The updated, elegant design is suitable for all types of interiors.



Voice Control.

Control without boundaries and get hands-free help to fully access the features of your air conditioners. Maximising your cooling comfort is now a breeze with our Network-Enabled Air Conditioners with Panasonic's Comfort Cloud and Voice Control.

COMMERCIAL

The commercial range is constantly expanding so that you can always offer your clients the optimal solutions: high performance, silent machines and a complete range of ducts, cassettes and ceiling installations.

Panasonic PACi R32 up to 25,0 kW.

Panasonic PACi provides a wide range of heating & cooling solutions with R32 refrigerant from 3,6 to 25,0 kW. From residential to commercial applications, it's the low GWP solution.



R32 Big PACi with a Split-able Hide Away indoor.

New Hide Away indoor. The new light weight and compact body design can be split into 3 components, providing simplified installation within a space with narrow access.

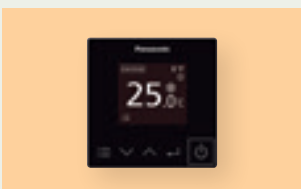

New wired remote controller.

Panasonic has developed the new wired remote controller to meet the modern control needs. The controller provides great accessibility and convenient tools in a stylish design.



Highly-Efficient Water Heat Exchanger for PACi series.

Providing not only an efficient operation with A++ Energy efficiency class*, but also 2 installation configurations (Wall-mounted and Floor-standing) meeting the needs of various spaces.

* Scale from A+++ to D.

VRF SYSTEMS

The VRF industrial range considerably improves efficiency so even large buildings can benefit from a high-level of comfort with less energy consumption.

VRF Systems ECOi EX.

A game-changing VRF system delivering outstanding energy saving performance. Taking quality to the extreme - that's the challenge by Panasonic.



ECO G 3 Series. + GHP/EHP Hybrid system.

Upgraded Gas Driven VRF - ECO G 3 Series. 3-Pipe ECO G GF3 provides free hot water effectively using waste heat generated by heating and cooling. Let's also take an advantage of Gas and Electricity with GHP/EHP Hybrid solution.



Mini ECOi LE Series.

The Mini ECOi combines smartly compact body with high specifications. It delivers high levels of energy-saving, powerful operation, reliability and comfort.



VRF Smart Connectivity+.

Panasonic's VRF Smart Connectivity is a completely new, state-of-the-art solution providing energy saving and comfort as well as simple installation, operation and running.

CHILLER

Panasonic introduces the new ECOi-W heat pump chiller series. This new series provides a wide variety of HVAC system solutions, to meet all of your residential, commercial and industrial needs.

ECOi-W, the solution for hotels, offices and industry.

High seasonal efficiency with the line-up from 20 kW to 210 kW. Fully customisable design gives high flexibility for commercial applications.



BMS integration.

Modbus RTU is included as standard in full range and additional optional BMS connection by Modbus and BACnet is also available.



Quiet operation in full range.

The full range provides very low noise operation thanks to the compressor phonic insulation. The level of quiet operation is outstanding in the market.



Simple user friendly control.

A control panel with intuitive design is equipped on all ECOi-W systems as standard.

REFRIGERATION

Panasonic condensing units with natural refrigerant.

Panasonic is now introducing the environmentally friendly CO₂ condensing units for commercial refrigeration.

Natural refrigerant CO₂.

CO₂ is a very attractive refrigerant from an environmental perspective. Zero ODP and "GWP" (Global Warming Potential) =1 means natural substance in the atmosphere.



New line-up 7,5 kW MT Type.

Medium temperature operation (evaporation temperature set point range -20 ~ -5 °C). Maximum cooling capacity: 7,4 kW* (ET -10 °C AT 32°). Slim & light unit with 1 fan. Heat Recovery port available.



CO₂ Condensing units CR Series by trusted technology.

CR Series are made in Japan with an excellent quality control established by skilled factory team.



Modbus compatibility with monitoring system.

Panasonic CO₂ condensing units can be supervised by major monitoring system such as CAREL, Eliwell and Danfoss.

EDITORIAL

- 6 A DESIRE TO CREATE THINGS OF VALUE
- 8 A GLOBALLY TRUSTED AIR CONDITIONING BRAND
- 10 100 % PANASONIC, THE DNA OF JAPANESE CRAFTSMANSHIP
- 12 NANO^E™ X - PANASONIC UNIQUE TECHNOLOGY TO IMPROVE INDOOR AIR QUALITY
- 14 PANASONIC: ECO & SMART IDEAS FOR A SUSTAINABLE LIFESTYLE
- 16 PROJECTS & CASE STUDIES OF PANASONIC HEATING AND COOLING SOLUTIONS
- 18 PRO CLUB. THE PROFESSIONAL WEBSITE OF PANASONIC

AQUAREA

- 20 WELCOME TO AQUAREA AIR TO WATER HEAT PUMP
- 22 HIGHLIGHTED FEATURES
- 24 INTRODUCING THE PANASONIC AQUAREA – AIR SOURCE HEAT PUMP
- 26 AQUAREA HEAT PUMP LINE-UP
- 28 AQUAREA, TOP-LEVEL EFFICIENCY ACROSS THE BOARD
- 30 AQUAREA ALL IN ONE
- 32 AQUAREA HIGH PERFORMANCE
- 34 AQUAREA T-CAP
- 36 AQUAREA HT
- 38 AQUAREA COMMERCIAL
- 40 AQUAREA SMART CLOUD FOR END USERS
- 41 AQUAREA SERVICE CLOUD FOR INSTALLERS / MAINTENANCE
- 42 CONTROL AND CONNECTIVITY
- 43 AQUAREA + PV PANELS
- 44 PANASONIC PRO CLUB MAKES YOUR LIFE EASIER. ALL AQUAREA DESIGN TOOLS CAN BE FOUND THERE
- 45 AQUAREA DESIGN TOOLS
- 46 AQUAREA HEAT PUMPS LINE-UP
- 64 SMART FAN COILS
- 65 FAN COILS
- 66 SANITARY TANKS
- 68 HEAT RECOVERY VENTILATION UNIT
- 70 DHW STAND ALONE
- 72 ACCESSORIES AND CONTROL
- 74 HEATING & COOLING CAPACITY TABLES
- 85 EXAMPLES OF INSTALLATIONS

DOMESTIC

- 86 WELCOME TO DOMESTIC RANGE
- 88 HIGHLIGHTED FEATURES
- 90 NANO^E™ X. QUALITY AIR FOR LIFE
- 92 ETHEREA STYLISH AND OUTSTANDING FEATURES
- 94 HEATCHARGE. ENERGY CHARGE SYSTEM
- 96 NEW WALL-MOUNTED TZ SUPER-COMPACT
- 98 NEW, SUPER-COMPACT UNITS, REDESIGNED FOR SIMPLE INSTALLATION AND MAINTENANCE
- 100 FLOOR CONSOLE. EFFICIENT COMFORT AND CLEAN AIR ALL YEAR ROUND
- 102 PANASONIC R2 ROTARY COMPRESSOR
- 104 R22 RENEWAL. PANASONIC STANDARD UNITS CAN BE INSTALLED ON EXISTING R22 PIPINGS
- 106 COMFORT CLOUD APPLICATION. CONVENIENT CENTRALISED CONTROL
- 108 NEW VOICE CONTROL. WORDS DO MORE THAN ACTIONS
- 110 CONTROL AND CONNECTIVITY
- 112 DOMESTIC AIR CONDITIONER RANGE R32
- 122 MULTI SPLIT AND FREE MULTI SYSTEM
- 128 FEATURE COMPARISON
- 130 FEATURES EXPLAINED
- 131 ACCESSORIES AND CONTROL
- 133 FREE MULTI R32 COMBINATIONS TABLE

COMMERCIAL

- 150 PANASONIC COMMERCIAL AIR TO AIR
- 152 HIGHLIGHTED FEATURES
- 154 PACi OUTDOOR UNITS. ENERGY SAVING CONCEPT
- 156 PACi ELITE: EXCELLENT SEER AND SCOP VALUES
- 158 GENERATION PACi 90X90 CASSETTE
- 160 SOLUTIONS FOR 24/7/365 APPLICATIONS
- 162 RANGE OF COMMERCIAL UNITS R32
- 190 PACi SINGLE, TWIN, TRIPLE AND DOUBLE-TWIN SYSTEM
- 196 PRO-HT TANK SERIES FOR PACi
- 200 PACi WITH WATER HEAT EXCHANGER · R32 REFRIGERANT
- 204 PANASONIC VENTILATION SOLUTIONS
- 205 ELECTRIC AIR CURTAIN
- 206 AIR HANDLING UNIT KIT 3,6-25,0 KW FOR PACi
- 208 AIR CURTAIN WITH DX COIL, CONNECTED TO THE VRF OR PACi SYSTEMS.
- 210 PANASONIC PACi ELITE CAN COOL ROOMS DOWN TO 8 °C
- 212 R22 RENEWAL. FAST, EASY TO INSTALL AND COST EFFECTIVE
- 216 ACCESSORIES AND CONTROL

VRF SYSTEMS

- 218 COMMERCIAL VRF SYSTEMS
- 220 VRF HIGHLIGHTED FEATURES
- 222 PANASONIC: DELIVERING TOP ENERGY EFFICIENCIES FOR MANY YEARS
- 224 PANASONIC VRF: TOP IN COMFORT
- 226 SOLUTIONS FOR RESTAURANTS
- 228 YOUR ENTIRE HOTEL WITH SUPERIOR COMFORT, CONTROL AND SAVINGS TOO
- 230 INNOVATIVE SOLUTIONS FOR RETAIL
- 232 RANGE OF VRF OUTDOOR UNITS
- 234 BEST EFFICIENCY ECOi SERIES FROM PANASONIC
- 236 MINI ECOi LE SERIES FOR LIGHT COMMERCIAL & RESIDENTIAL USE
- 242 ECOi EX THE GAME CHANGER
- 264 EUROVENT CERTIFIED TECHNICAL DATA
- 266 ECO G, THE GAS DRIVEN VRF
- 276 PANASONIC GHP/EHP HYBRID SYSTEM
- 280 WATER HEAT EXCHANGER FOR HYDRONIC APPLICATIONS
- 284 LEAK DETECTION AND AUTOMATIC REFRIGERANT PUMP DOWN
- 285 DESIGN SUPPORT SOFTWARE FOR VRF
- 286 VRF SYSTEMS INDOOR UNITS
- 288 ECOi AND ECO G SYSTEMS INDOOR UNITS RANGE
- 306 PRO-HT TANK SERIES FOR ECOi
- 308 SMART FAN COILS
- 309 FAN COILS
- 310 PANASONIC VENTILATION SOLUTIONS
- 312 AHU CONNECTION KIT 16, 28 AND 56 KW FOR ECOi AND ECO G
- 314 AIR CURTAIN WITH DX COIL, CONNECTED TO THE VRF OR PACi SYSTEMS
- 316 ENERGY RECOVERY VENTILATION
- 318 HEAT RECOVERY WITH DX COIL
- 320 DIMENSIONS AND TUBE SIZES OF BRANCHES AND HEADERS
- 322 ACCESSORIES AND CONTROL

HEAT PUMP CHILLERS

- 368 DISCOVER A NEW ERA OF ECOi, THE ECOi-W. HEAT PUMP CHILLERS
- 370 ECOi-W MEETS THE CUSTOMER'S NEEDS, WITH THIS FULLY CUSTOMISABLE HEAT PUMP CHILLER
- 372 ECOi-W, THE SOLUTION FOR HOTELS, OFFICES AND INDUSTRY
- 374 PANASONIC CERTIFIED QUALITY
- 376 RANGE OF ECOi-W OUTDOOR UNITS
- 386 CONTROL
- 387 FAN COILS APPLICATION WITH ECOi-W HEAT PUMP CHILLER SYSTEM
- 388 MODEL REFERENCING AND OPTIONS

CONTROL AND CONNECTIVITY

- 328 CONTROL AND CONNECTIVITY
- 330 VRF SMART CONNECTIVITY+
- 336 PANASONIC AC SMART CLOUD
- 338 COMMERCIAL WLAN ADAPTOR
- 340 NEW WIRED REMOTE CONTROLLER - CZ-RTC6 / CZ-RTC6BL / CZ-RTC6BLW
- 342 REMOTE CONTROLLER WITH ECONAVI
- 344 DATANAUI
- 346 INTELLIGENT CONTROLLER
- 348 ECONAVI SENSOR
- 350 CONTROLLER FOR HOTEL APPLICATION
- 352 BMS INTERFACE WITH P-LINK
- 354 CONTROL AND CONNECTIVITY
- 356 INDIVIDUAL CONTROLLERS
- 359 CENTRALISED CONTROLLERS
- 364 PACi AND VRF CONTROL AND CONNECTIVITY
- 366 ECOi, ECO G AND PACi CONNECTIVITY INDOOR UNITS

REFRIGERATION

- 390 PANASONIC CONDENSING UNITS WITH NATURAL REFRIGERANT
- 392 CHOOSE THE GREEN SOLUTION BY PANASONIC
- 394 NATURAL SOLUTION WITH HIGH ENERGY SAVING
- 396 CO₂ TRANSCRITICAL CONDENSING UNITS CR SERIES
- 398 TECHNOLOGY BY PANASONIC
- 400 RANGE OF CO₂ CONDENSING UNITS CR SERIES

402 DIMENSIONS

452 WIRING DIAGRAMS



Quality Management System Certificate



Certified to ISO 9001: 2008
Panasonic Appliances Air-Conditioning
Malaysia. Sdn.Bhd.
Cert. No.: MY-AR 1010



Certified to ISO 9001: 2008
Panasonic Appliances Air-Conditioning
(GuangZhou) Co., Ltd.
Registration Number: 01209Q20645R5L

Environmental Management System Certificate



Certified to ISO 14001: 2004
Panasonic Appliances Air-Conditioning
Malaysia Sdn.Bhd.
Cert. No.: MY-ER0112



Certified to ISO 14001: 2004
Panasonic Appliances Air-Conditioning
(GuangZhou) Co., Ltd.
Registration Number: 02110E10562R4L

A desire to create things of value

"Recognising our responsibilities as industrialists, we will devote ourselves to the progress and development of society and the well-being of people through our business activities, thereby enhancing the quality of life throughout the world."

Panasonic Corporation's Basic Management Objective, formulated in 1929 by the company's founder, Konosuke Matsushita.



Panasonic becomes the first Japanese air conditioner manufacturer in Europe.



Introduces world's first simultaneous 3-Pipe heating/cooling VRF System.



Starts production of absorption chillers.



1958

1971

1973

1975

1985

1989



Panasonic launches the first highly efficient air-to-water heat pump in Japan.



First room air conditioner launched for domestic installation.



Introduces first GHP (gas heat pump) VRF air conditioner.

New Aquarea. Panasonic introduces Aquarea, an innovative new, low-energy system in Europe.



The first Hybrid System with VRF and GHP in Europe.



World's first air conditioner equipped with nanoe™



CO₂ condensing units in Europe. The ideal solution for supermarkets, shops and gas stations.



2008

2010

2012

2015

2016

2018

Looking ahead



Ethera new concept: high efficiency and high performances with a great design.



New VRF Systems ECOi EX with extraordinary energy-saving performance.



New Panasonic GHP units. The gas-driven VRF Systems are ideal for projects where power restrictions apply.



Panasonic introduces a new Heat Pump Chiller series which is named as ECOi-W.

A Globally Trusted Air Conditioning Brand



Panasonic – leading the way in Heating and Cooling.
With more than 50 years of experience, selling to more than 120 countries around the world, Panasonic is one of the leaders in the heating and cooling sector.

With a diverse network of production and R&D facilities, Panasonic delivers innovative products incorporating cutting-edge technologies that set the standard for air conditioners worldwide.

Expanding globally, Panasonic provides superior international products transcending borders.



100 % Panasonic: we control the process

The company is also a world leader in innovation as it has filed more than 91539 patents to improve its customers' lives. Moreover, Panasonic is determined to remain at the forefront of its market. In all, the company has produced more than 200 million compressors and its products are manufactured in 294 plants which are located all over the world. You can be assured of the extremely high quality of Panasonic's heat pumps.

This wish to excel has made Panasonic a leading company in heating and turn-key air conditioning solutions. These offer maximum effectiveness, comply with all environmental standards and meet the most avant-garde construction requirements of our time.

Constantly Improving

At Panasonic, we know that the best is always yet to come. This is why our air conditioning and heat pump solutions are constantly upgraded. Panasonic is committed to offering our customers innovative products in the heating and cooling market across Europe, and has the ambition to not only meet but also exceed their requirements. Our Technology & Design teams anticipate the needs of tomorrow. We look to produce smaller, quieter, efficient solutions - with better technological features – that can reduce energy consumption while providing suitable temperature conditions for the user.

40 years of experienced organization in Europe

The partner for all Europe.

- Full European coverage and integrated organization
- One voice for European Agreements
- Availability and delivery anywhere in Europe
- Specification team to support project design throughout Europe
- European Service Network

Trained professionals.

- 22 Training centres in 15 countries
- More than 5000 professionals trained every year. Innovation and manufacture in Europe

R&D Department designs solutions for different European needs.

- New factory set up in Czech Republic
- Design software made in Europe for Europe

More than Cooling, Heating and Refrigeration Solutions.

- Security, communication solutions, advanced digital signage technology, access control solutions, displays...



100 % Panasonic, the DNA of Japanese craftsmanship

JAPAN
QUALITY



Applying advanced technologies that truly make life better, we live by an unparalleled commitment to product quality.

Panasonic is building on the Japanese tradition of uncompromising quality control worldwide, developing and manufacturing fine products and delivering them to customers everywhere.

At Panasonic, we believe that the best air conditioner is one that works quietly and effectively in the background whilst minimising its impact on the environment

People who use our products can look forward to long years of high-quality performance without the need for constant service. As part of our rigorous design and development process, Panasonic air conditioners undergo a variety of stringent tests to ensure their effectiveness and long-term reliability. Tests for durability, waterproofing, shock resistance, and noise are conducted on component parts or on the finished products themselves.

As a result of all of these time consuming efforts, Panasonic air conditioners meet industrial standards and regulations in every country where they are sold.

International Standard Quality

To uphold the company's reputation around the world, Panasonic strives continuously to offer quality with minimized environmental impact.

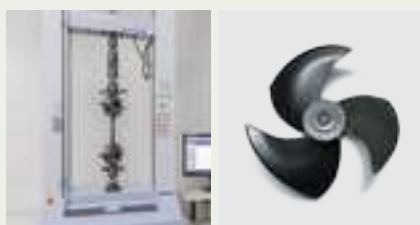

Reliable parts that meet or exceed industrial standards.

In every country where they are sold, Panasonic air conditioners comply with all required industrial standards and regulations. In addition, Panasonic conducts stringent testing to ensure the reliability of parts and materials. The strength of the resin material used in a propeller fan is confirmed by a tension test.



Compliance with RoHS / REACH substance restrictions.

Panasonic products and used materials strictly comply with chemical substance restrictions as defined by RoHS or REACH. During the development and production of parts, stringent inspections are conducted on over 100 materials to ensure that no hazardous substances are included.



Sophisticated production process.

Panasonic's air conditioner production lines employ state-of-the-art factory automation technologies to ensure products are manufactured with high attention to quality to meet expectations of reliability and trustworthiness.

Durability

At Panasonic we know the importance of a long service life with minimal maintenance. That's why we subject our air conditioners to a wide range of stringent durability tests.



Long-term durability test.

To ensure durability and stable operation for many years, we conduct a long-term continuous operation test under conditions that are much more severe than actual operating conditions.



Compressor reliability test.

After the continuous operation test, we remove the compressor from a selected outdoor unit, disassemble it, and examine the internal mechanisms and parts for potential failure. This helps ensure reliable long-term performance under harsh conditions.



Waterproofing test.

The unit - which is subject to rain and wind - complies with IPX4 waterproof specifications. Contact sections on printed circuit boards are resin-potted to prevent adverse effects caused by exposure to water (an unlikely occurrence).

nanoe™ X - Panasonic unique technology to improve indoor air quality



Let Panasonic take care of indoor air quality. nanoe™ X inhibits a wide variety of bacteria, viruses and pollutants, and deodorises the environment. This unique technology is equipped to provide better air quality whether residential or commercial.



7 effects of nanoe™ X – Panasonic unique technology

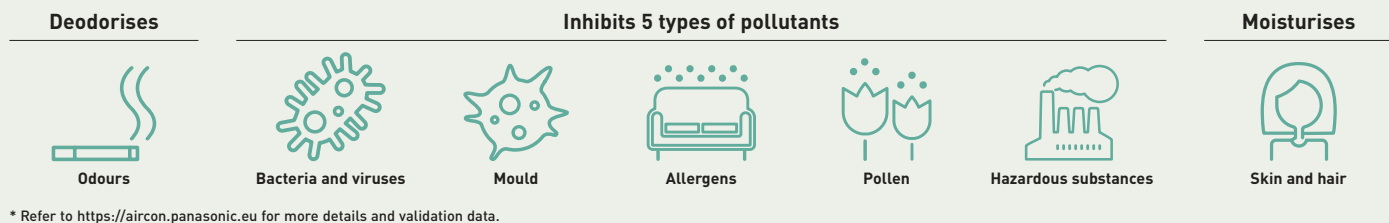

* Refer to <https://aircon.panasonic.eu> for more details and validation data.

How nanoe™ X works

nanoe™ Technology by Panasonic has been updated from nanoe™ to nanoe™ X. nanoe™ X improves the indoor air quality in commercial application.

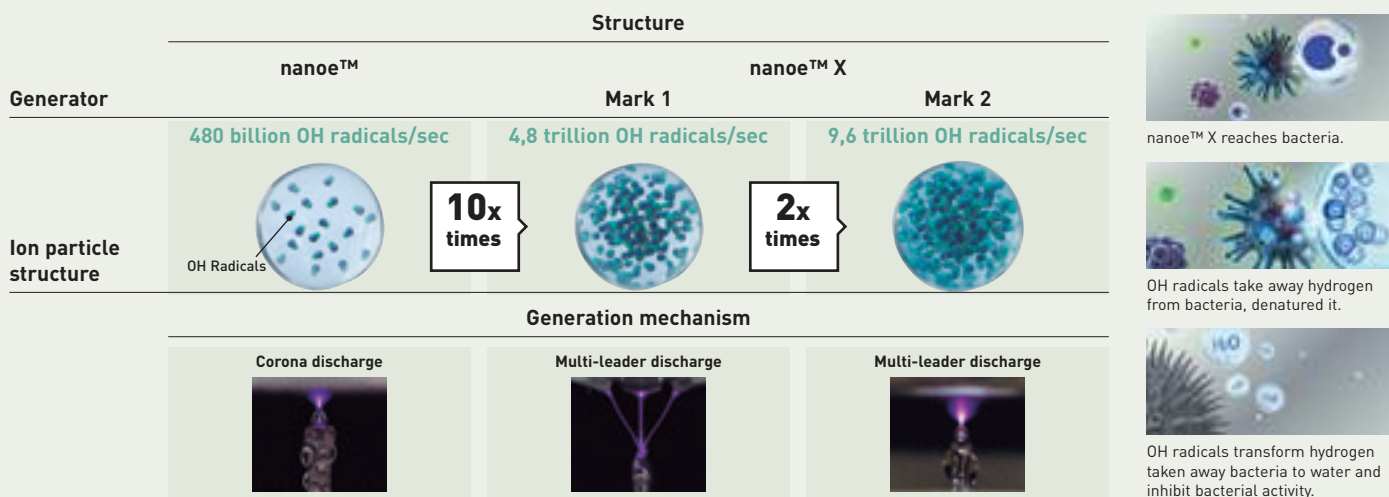

nanoe™ X reaches bacteria.

OH radicals take away hydrogen from bacteria, denatured it.

OH radicals transform hydrogen taken away bacteria to water and inhibit bacterial activity.

nanoe™ and nanoe™ X world in Japan

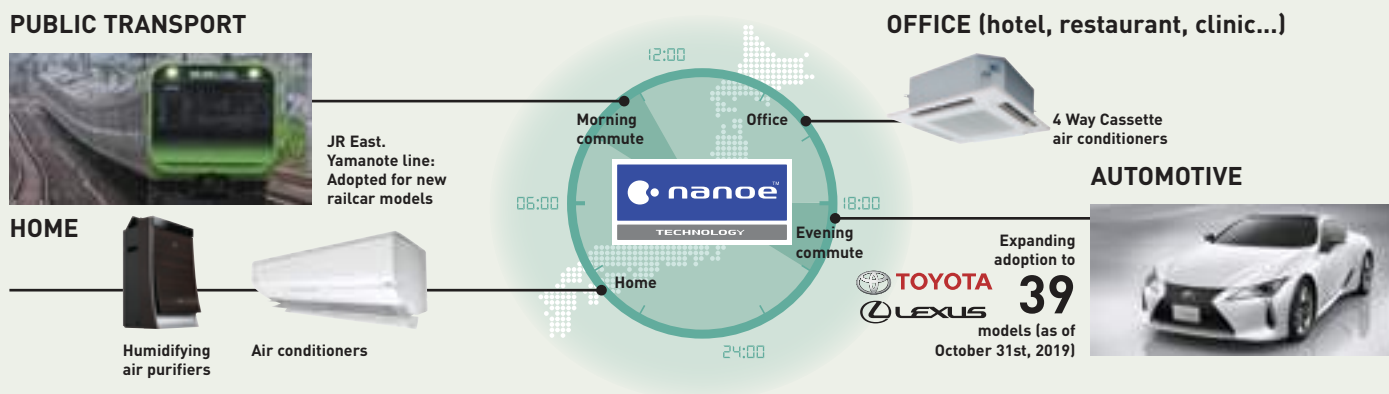

International validation

Effectiveness of nanoe™ Technology has been tested by 3rd parties laboratories in Denmark, Malaysia and Japan.

99,9 %*
OF CERTAIN BACTERIA INHIBITED

Reduction of 99,9% of Staphylococcus aureus after 8 hours of exposure. Texting organisation: Danish Technological Institute. Report no. 868988.



Denmark

Malaysia

Japan



Panasonic: Eco & smart ideas for a sustainable lifestyle



A better life, a better world.
Panasonic is creating a safe and secure society
with clean energy.



www.future-living-berlin.com

FUTURE LIVING®
BERLIN

Smart City Quarter Berlin

A European Lighthouse Project for Smart Home & Connected Life. Future Living® Berlin.

The building project Future Living® Berlin is a future model for interconnected urban district. Since 2013 GSW Sigmaringen and Unternehmensgruppe Krebs are developing a model for future living – based on their long term expertise in real estate business and in cooperation with leading international technology companies. In spring 2019 first residents will move into the new quarter.

Future Living® Berlin is making use of the increasing possibility to interconnect products and services. Based on this chance smart and intelligent solutions for future living as well for the single apartments as for the quarter are developed. These solutions are enabling residents to use online services in their intelligent housing environment. Based on these opportunities a concept of living for daily routine is developed offering residents comfort, security and time saving.

A special enhancement of Future Living® Berlin is the pre-configuration for different apartments by experts that enable residents to move into a “ready to go” apartment and be directly supported in their daily routines in an intelligent way. By using one central app or native language single apartments can be steered, adopted and individually expanded by future smart products. Cross-linkage of products and technologies provides all residents with a simple access for an exclusive community

care sharing in the residential quarter which is, of course, based on e-mobility and part of an holistic energy concept containing photo-voltaic systems and battery storage. Cooperating with leading technology companies as project partners a continuous and technological progression is guaranteed in the future. Including residents and learning from their usage data participating partner a ready and enabled to improve the offered solutions pointedly further more.

Beside Future Living® Homes there is Future Living® Dialog offering extensive information and use cases for the general public. The project with it's innovative aims is also representing for sustainability and social solutions. Affordable rental and ancillary rental costs result in apartments available for many target groups. Future Living® Berlin is aiming for conceptional and architectural answers for some of the big challenges of our society as demographical changes, energy turnaround and changing mobility manners. With it's comprehensive solution approach it is unique in Europe.

Demographic change, energy revolution and mobility change. We offer solutions for the challenges of our time.

Projects & Case Studies of Panasonic Heating and Cooling Solutions



Panasonic, a partner with the knowledge and experience to achieve your objectives and green needs.

Integrated technology that permits better work, easy installation, high efficiency performance, and energy savings

Our main targets are the distributed services and B2B-integrated solutions.

Panasonic provides a single point of contact for the design and maintenance of your system, making things easy for you. Given our experience in processes, technologies and complex business models, we can offer you effective solutions that reduce costs, whilst also being efficient, user-friendly, reliable and innovative. Another advantage we offer to our clients is a support service for systems integration projects, which we provide through our wide range of services and solutions. As a global company, we have at our disposal the financial, logistical and technical resources to develop complex and wide-ranging solutions, both at country and international level by implementing them both on-time and on-budget.



Bulgaria's stand-out residential building with efficient HVAC solution. **Aquarea**



The new Hotel Vincci Gala with efficiency class A, up to 70 % save energy. Barcelona, Spain. **ECOi - ECO G**



New IKEA "Click and Collect" store in city centre. Birmingham, UK. **ECOi - ECO G**



9 high quality homes in Whittle-Le-Woods near Chorley, UK. **Aquarea**



Andalusia Technology Park. Offices of high energetic efficiency. Spain. **ECOi**



14 bubble style domes to bring a 180-degree transparent window to the nature. Belfast, Ireland. **Aquarea**



Madrid's new hotel Only You Atocha. The hotel has 206 rooms distributed over seven floors. **ECO G**



LIAIGRE showroom, well-known as a luxury design architect in Paris, France. **ECOi**



Marina Village Greystones. 205 apartments and 153 houses. Ireland. **Aquarea**



ITK Engineering GmbH. An innovative office building located in Germany. **ECOi - PACi**



Zalando's solution for its warehouse office conversion at Grand Canal Quay, Dublin. **ECOi**



NHS Canford house clinic, Bournemouth, UK. **VRF**

To find out more: www.aircon.panasonic.eu

PRO Club. The professional website of Panasonic



Panasonic PRO Club (www.panasonicproclub.com) is the online tool which makes your life easier! You just have to register and a lot of functionalities are freely available to you, where ever you are, from your computer or smartphone!

- Print catalogues with your logo and your address
- Download the latest Aquarea designer to define your system and select the good Aquarea Heat pump.
- Calculate the specs of the fan coil based on the parameters of your system
- Get Documents of conformity and all other documents you may need
- Download all the service manuals, end user manuals and installation manuals
- Know what to do with error codes
- Find out about the latest news first
- Register for training

Highlighted Features.

- Extensive library of resources
- Tools & Apps for end users. Check availability in your country:
 - My Home: sizing wizard for domestic and Air to Water range
 - My Project: Contact form to Panasonic team
 - iFinder: Lists of installers displayed by postcode

- Special offers & promotions
- Training PRO Academy
- Catalogues (Commercial documentation)
- Marketing (Images in high resolution, advertisements, dECO Guidelines)
- Tools (Professional software, sizing tools...)
- Installers customize leaflets in PDF format with their logo & contact details
- Energy label generator. Download energy labels of any device in PDF format
- Heating calculator
- Noise calculator for outdoor unit
- Aquarea Radiator calculator
- Error Code Search by error code or unit ref. Compatible with smartphone and tablet computer
- Revit / CAD Images / Spec texts
- Access to Pananet, online library of technical documentation
- Download Documents of Conformity and other Certifications
- Commissioning online

Panasonic PRO Club is fully compatible with tablet computer and smartphone.



Easy download Panasonic service documentation and brochures



Customise leaflets with your logo & contact details. Save and print the PDF



Energy label generator. Download Energy labels of any device in PDF format



Error Code on your smartphone and your PC: Search by error code or model reference. Online version + downloadable version for offline use

Panasonic has an impressive range of support services for designers, specifiers, engineers and distributors working in the heating and cooling markets.



Aquarea Designer

This program allows HVAC designers, installers and distributors to identify the correct heat pump for a particular application from Panasonic's Aquarea range, calculate the savings compared to other heat sources and very quickly calculate CO₂ emissions.

Using Panasonic's Aquarea Designer, projects can be developed simply and easily, by either using the Quick Design or Expert Design options. Each allows the user to build up the project data in a simple step-by-step process and choose to output reports (in either Quick or Large formats) as HTML files or as print-outs. To create these useful reports, project data is input, including:

- Heated area
- Heating requirement
- Heating flow and return temperatures
- Climate data (from a simple drop-down menu) including outdoor temperature
- Type of hot water tank, storage capacity and hot water target temperature

Panasonic provides bespoke software helping system designers, installers and dealers to very quickly design and size systems, create wiring diagrams and issue bills of quantities at the push of a button.



Aquarea Designer also means saving

Aquarea Designer will calculate the project's energy costs in terms of hot water, heating and pumping. It will show the equipment running times and calculate the COP (coefficient of performance). It then allows the designer to show clients a comparison with other equipment options such as heating by conventional gas-fired boilers, oil systems, wood, standard electric heating and electric night storage heaters. This compares running costs, initial investment costs and maintenance costs. The comparison can also be made for CO₂ emissions and savings.

The Panasonic PRO Academy

Panasonic takes its responsibility to its distributors, specifiers and installers seriously and has developed a comprehensive Training Programme. The Panasonic Pro-Academy encompasses the traditional hands-on approach to teaching.

New training courses cover three levels. Design, installation, and commissioning & trouble-shooting.

Training courses include:

- Domestic applications Air to Air
- Aquarea air source heat pumps
- VRF ECOi

The courses are offered on site at Panasonic's premises across Europe. The Training Centres display Panasonic's latest product range and give delegates an opportunity to get a hands-on experience with the latest controllers, indoor and outdoor units from the VRF ECOi, Etherea, GHP and Aquarea ranges.

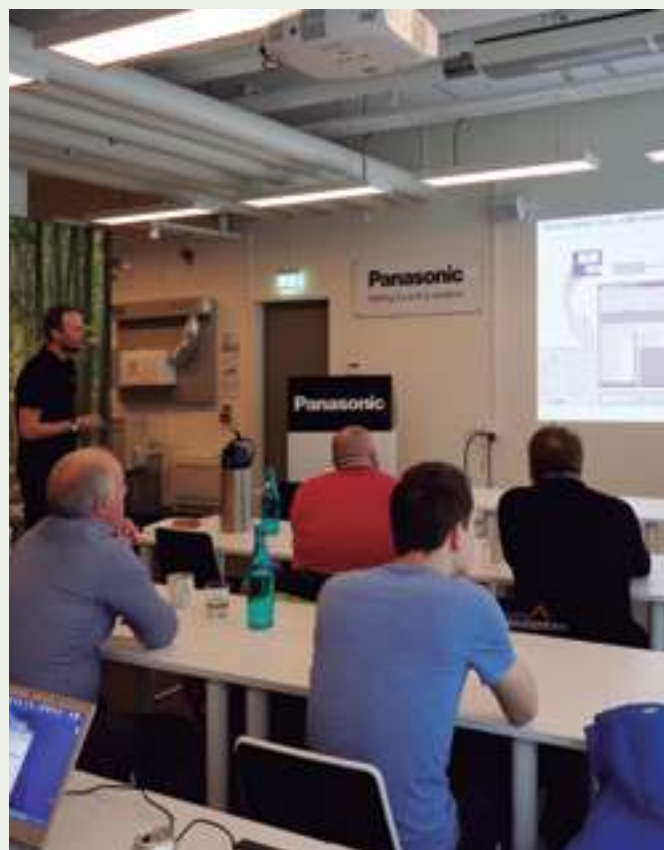

Download on www.panasonicproclub.com or connect simply with your smartphone to the PRO Club using this QR





Welcome to Aquarea air to water heat pump

Aquarea's Air to Water Heat Pump for residential and commercial applications. Offering capacities from 3 kW all the way through to 16 kW, the Aquarea Heat Pump Range is the widest on the market, ensuring a system is available, whatever your heating and cooling needs. Suitable for new build and refurbishment projects, the solutions are cost-effective with minimised environmental impact.

Highlighted Features



The Good Design Award is among the most prestigious awards for product design excellence. Winning this award has underscored the outstanding performance and energy savings of the Panasonic indoor units All in One and Bi-bloc. In addition, these units' clean, tidy design and functionality make the Aquarea line the ideal system for household applications.







Panasonic's Aquarea range of heat pumps deliver major energy savings thanks to its incredible efficiency even at -20 °C. The Panasonic Aquarea Heat Pumps are designed and produced by Panasonic and not by other companies.

The Aquarea Heat Pump is a system that generates the perfect temperature and produces hot water, in an easy, cheap and environmentally conscious way, by transferring heat instead of generating it. It is among the Technologies listed on the International Energy Agency (IEA) Blue Map, whose goal is to reduce CO₂ emissions to half the levels emitted in 2005, by the year 2050.

Aquarea is part of a new generation of heating solutions that use a renewable, free energy source (the air) to heat or cool the home and to produce hot water.

Energy saving





| | | | | | |
|--|---|---|---|--|--|
|  R32 |  A++ ErP 55°C |  A+++ ErP 35°C |  A+ DHW |  INVERTER+ | A CLASS WATER PUMP AUTO SPEED |
| Refrigerant gas R32 Our heat pumps containing the refrigerant R32 show a drastic reduction in the value of Global Warming Potential (GWP). | Better efficiency & value for medium temperature applications. Energy efficiency class up to A++ in a scale from A+++ to D. | Better efficiency & value for low temperature applications. Energy efficiency class up to A+++ in a scale from A+++ to D. | Better efficiency & value for domestic hot water. Energy efficiency class up to A+ in a scale from A+ to F. | Inverter Plus. Panasonic Inverter Plus compressors are designed to achieve outstanding level of performance. | A class water pump. Aquarea are built-in with A class energy efficiency water pump. High efficiency circulating the water in the heating installation. |

High Performance

| | | | | |
|--|---|---|--|--|
| 5,33 COP HIGH PERFORMANCE | -20°C CONSTANT HEATING T-CAP | 65°C OUTPUT WATER HIGH TEMPERATURE |  DHW |  -20°C HEATING MODE |
| Aquarea High Performance for low consumption houses. From 3 to 16 kW. For a house with low temperature radiators or under-floor heating, our high performance Aquarea HP is a good solution. *COP of 5,33 for J Generation 3 kW. | Aquarea T-CAP for extremely low temperatures. From 9 to 16 kW. If the most important aspect is to maintain nominal heating capacities even at temperatures as low as -7 °C or -20 °C, select the Aquarea T-CAP. | Aquarea HT ideal for retrofit. From 9 to 12 kW. For a house with traditional high-temperature radiators, the Aquarea HT solution is the most appropriate, can work in output water temperatures of 65 °C even at outdoor temperatures as low as -20 °C. | DHW. With Aquarea you can also heat your domestic hot water at a very low cost with the optional hot water cylinder. | Down to -20 °C in heating mode. The heat pumps work in heating mode with an outdoor temperature is as low as -20 °C. |

| | | | | |
|--|---|---|---|--|
|  WATER FILTER WITH MAGNET |  FLOW SENSOR |  5 YEARS COMPRESSOR WARRANTY |  | |
| Water filter with magnet. Easy access & fast clip technology for J Generation. Water filter only for H Generation. | Water flow sensor. Included on J and H Generation. | 5 years compressor warranty. We guarantee the outdoor unit compressors in the entire range for five years. | SG Ready: Thanks to Aquarea HPM, Aquarea HT range is holding the SG Ready Label (Smart Grid Ready Label), given by Bundesverband Wärmepumpe (German Heat Pump Association). This Label shows the real capacity of Aquarea to be connected in an intelligent grid control. MCS Certificate number: MCS HP0086.* Keymark: Check all our certified heat pumps on: www.heatpumpkeymark.com . | |

High connectivity

| | | | | |
|---|--|--|---|---|
|  BOILER CONNECTION |  SOLAR KIT |  ADVANCED CONTROL |  OPTIONAL WLAN |  BMS CONNECTIVITY |
| Renovation. Our Aquarea Heat Pumps can be connected to an existing or new boiler for optimum comfort even at very low outdoor temperatures. | Solar kit. For even greater efficiency, our Aquarea Heat Pumps can be connected to photovoltaic solar panels with an optional kit. | Advanced control. Remote controller with full dotted 3,5" wide back light screen. Menu with 17 available languages easy to use for installer and user. Included on J and H Generation. | Internet control. A next generation system providing user-friendly remote control of air conditioning or heat pump units from everywhere, using a simple Android™ or iOS smartphone, tablet or PC via the internet. | Connectivity. The communication port can be integrated into the indoor unit and provides easy connection to, and control of, your Panasonic heat pump to your home or building management system. |

Warning On Quality Of Water and Groundwater Use:
 This product is designed to comply with the European Water Quality Directive 98/83/EC amended by 2015/1787/EU. The lifespan of the product is not guaranteed in the case of the use of groundwater, such as spring water or well water, the use of tap water when salt or other impurities are contained, nor in areas of acidic water quality. Maintenance and warranty costs related to these cases are the customer's responsibility.

* Not all products certified. As the certification process is on-going and the list of certified products constantly changing, please check for latest details on the official websites.

Introducing the Panasonic Aquarea – air source heat pump



At the forefront of energy innovation, Aquarea is resolutely positioned as a “green” heating and air conditioning solution.

Introducing the Panasonic Aquarea – air source heat pump

In European households, 79 %* of energy consumption comes from heating and producing domestic hot water. By converting heat energy in the air into household warmth, highly efficient Aquarea technology reduces CO₂ emissions and environmental impact, compared to conventional boilers and electric heaters.

An Aquarea air source Heat Pump circulates fresh air and

passes it over refrigerant-filled coils (like a refrigerator). The captured heat is automatically transferred to water, which is then ready for use in your heating system and for supplying all of your domestic hot water needs. Panasonic’s latest technology offers you a sustainable alternative to oil, LPG and electric heating systems.

* ec.europa.eu/eurostat

Why Panasonic Aquarea air source heat pumps?



Optimum solutions for premium comfort.

Panasonic Aquarea Heat Pumps warm your home effectively and efficiently, they precisely control the indoor temperature thanks to reliable Panasonic Inverter Compressors. Aquarea can also cool space in summer and bring hot water all year round. Panasonic has created a night mode to reduce the noise when it’s needed. Aquarea offers enhanced connectivity to improve the comfort of users. For example, with ventilation equipment connected, it will make the indoor air cleaner and fresher. With solar panels, it can operate using renewable energy.



Adapts to your needs.

Panasonic Aquarea heat pumps produce heating, cooling and domestic hot water with a single system and can be connected to floor heating, radiators or fan coil units. In refurbishment projects Aquarea can be integrated in existing heating systems. Aquarea is able to reach up to 60 °C water outlet and allows high flexibility in installation thanks to the large piping length of up to 50 m between indoor and outdoor (see table each model limitations). From 3 kW to 16 kW, there is always an option for lower initial investment and lower operational cost.



Energy saving means money savings.

Panasonic Aquarea heat pumps are a smart choice for saving in heating, as they provide savings of up to 80 % on heating expenses compared to electrical heaters. Aquarea units reach A+++ within the range of A+++ to D in heating and A+ in the range of A+ to F in domestic hot water, all leading to large savings in electricity bills. Compared to an electric heater, the Air to Water Heat Pump offers five times the output in kilowatts per every input in kilowatts. Consumption can be further reduced by connecting photovoltaic solar panels to the system.



Contributing to a decarbonised society.

The Air to Water Heat Pump is powerful technology designed with the future in mind. The heat pump is considered a ‘green’ choice as the heat energy is taken from the environment, making it a sustainable option. It maintains a comfortable indoor temperature while significantly reducing environmental burden. All Aquarea heat pumps can also be connected to a solar thermal or PV system in order to increase efficiency and minimise environmental impact.

Panasonic Aquarea key points

- Panasonic’s unique software and inverter technology for low consumption houses, allows the heat pump to produce heating water at 35 °C.
- Most of the Aquarea heat pumps have a 10 L expansion vessel fitted internally
- Inverter compressor which can regulate the output capacity depending on demand
- Twin dice system included within the system (twin fan outdoor unit)
- 3/6/9 kW electrical heater included in the heat pump (depending on unit)
- Panasonic Aquarea T-CAP heat pumps can work in outdoor temperatures as low as -28 °C (for All in One and Bi-bloc, -20 °C for Mono-bloc) and guarantee the capacity without backup heating down to -20 °C¹⁾
- Panasonic heat pumps are very quiet and have a noise reduction setting for night mode

1) 35 °C flow temperature.

Comparison: 1 kW input versus output in kW.

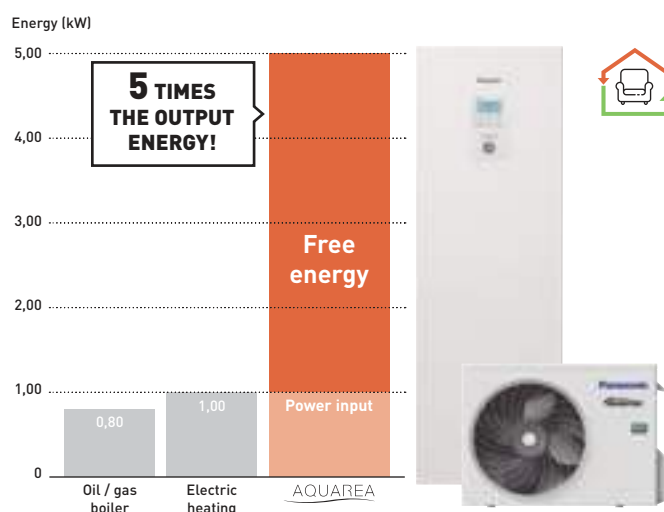

Aquarea Heat Pump Line-Up

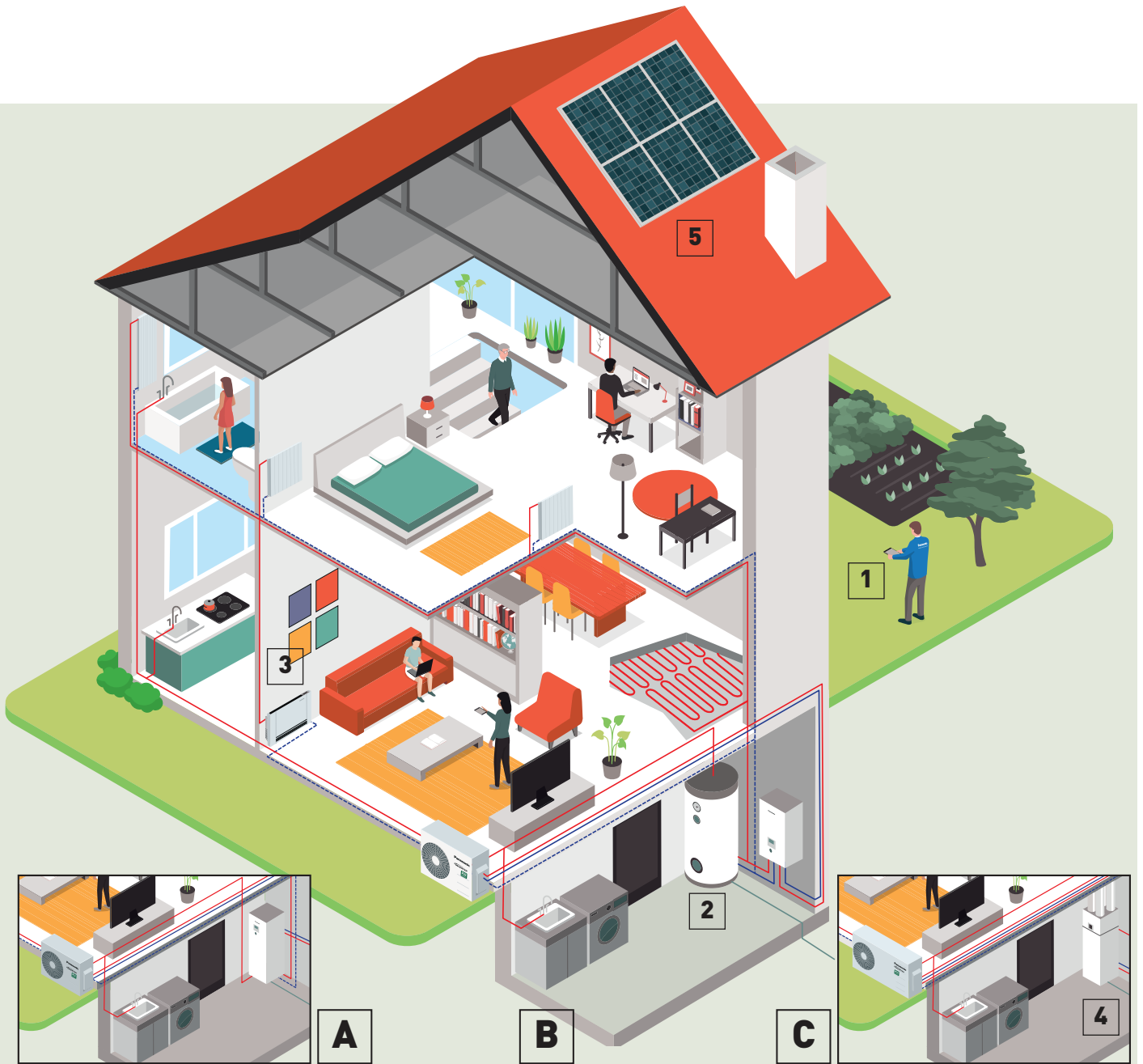

A All in One system.



B Bi-bloc system.



C Mono-bloc system.

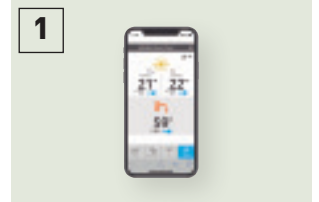

1 Control through smartphone, tablet or computer (optional).



2 Super High Efficiency cylinder (optional).



3 Fan coils for heating and cooling (optional).



4 Heat Recovery Ventilation + DHW Tank (optional).



5 Heat Pump + HIT Photovoltaic solar panel (optional).

Panasonic Aquarea offers you solutions, helping to make the home more efficient and the installation cheaper and easier.

Aquarea High Performance

For new installations and low consumption homes.

Outstanding efficiency and energy savings with minimised CO₂ emissions and minimum space. Improved performance with COPs up to 5,33 for J Generation 3 kW.

Aquarea T-CAP

For extremely low temperatures, refurbishment and innovation.

Ideal to ensure that the heating capacity is maintained even at very low temperatures. This line-up is able to maintain the heat pump output capacity until -20 °C outdoor temperature without the help of an electrical booster heater.

Aquarea HT













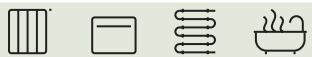

For a house with old high-temperature radiators.

Ideal for retrofit: green energy source works with existing radiators. Aquarea HT Solution is the most appropriate, providing output water temperatures of 65 °C even at outdoor temperatures as low as -15 °C.

DHW Stand Alone

Highly efficient heat pump water heater.

Ideal to cover the hot water needs of a family house, stand-alone DHW heat pumps are designed to provide maximum comfort and savings in the production of DHW. Consumption of the A+ DHW heat pump is reduced by 75 % compared with traditional electric water heaters.

| Aquarea High Performance | Aquarea T-CAP | Aquarea HT | DHW Stand Alone |
|---|---|--|---|
|  Heating - Cooling - DHW Single Phase from 3 to 16 kW Three Phase from 9 to 16 kW |  Heating - Cooling - DHW Single Phase from 9 to 12 kW Three Phase from 9 to 16 kW |  Heating - DHW Single Phase from 9 to 12 kW Three Phase from 9 to 12 kW |  Only DHW From 100 to 270L |
| Connectable to | | | |
|  Radiators - Fan coil - Underfloor heating - DHW |  Radiators - Fan coil - Underfloor heating - DHW |  Traditional high-temperature radiators - DHW |  Domestic hot water |
| Application | | | |
|  Normal installation |  For extreme cold ambient |  Retrofit for old radiators |  Only DHW |
| Energy efficiency | | | |
|  Heating 35 °C / 55 °C ¹⁾ |  Heating 35 °C / 55 °C ¹⁾ |  Heating 35 °C / 55 °C ¹⁾ |  DHW 50 ~ 62 °C ²⁾ |
| Minimum outdoor temperature | | | |
| -20 °C | -28 °C (All in One and Bi-bloc) -20 °C (Mono-bloc) ³⁾ | -20 °C | -5 °C |
| Minimum outdoor temperature to provide constant capacity at 35 °C supply water temperature | | | |
| -7 °C (not for all units) | -20 °C ³⁾ | -15 °C | — |
| Supply temperature for heating. Maximum / Heat pump only | | | |
| 75 °C ⁴⁾ / 55 °C ⁵⁾ (or 60 °C for Aquarea J Generation) | 75 °C ⁴⁾ / 60 °C ⁵⁾ | 75 °C ⁴⁾ / 65 °C | — |
| Control and connectivity | | | |
| Smart Grid Ready ⁶⁾ Wireless LAN Ready | Smart Grid Ready ⁶⁾ Wireless LAN Ready | — | — |
| Range | | | |
| Bi-bloc from 3 to 16 kW Mono-bloc from 5 to 16 kW All in One from 3 to 16 kW (185L) | Bi-bloc from 9 to 16 kW Mono-bloc from 9 to 16 kW All in One from 9 to 16 kW (185L) | Bi-bloc from 9 to 12 kW Mono-bloc from 9 to 12 kW | Wall-mounted 100 and 150L Floor-standing 200 and 270L |

All data in this chart is applicable in most of models in each line up, check product specs to confirm. 1) Scale from A+++ to D. 2) Scale from A+ to F. 3) 9 and 12 kW. 4) DHW maximum temperature with heater. 5) In case of outdoor temperature over -10 °C. 6) H Generation with CZ-NS4P, F and G Generation with Heat Pump Manager. * DHW Stand Alone is produced by S.A.T.E.

Aquarea, top-level efficiency across the board



Aquarea J Generation: much more than Aquarea in R32. Available in 3/5/7/9 kW All in One, Bi-bloc and 5/7/9 kW Mono-bloc.

1 Keeping Aquarea essence

- Free space on the top of All in One
- A+++ in heating mode at 35 °C (scale from A+++ to D)
- Service Cloud by accessory

2 Higher efficiency

- SCOP up to + 5 % vs H Generation
- DHW COP up to 3,30 (for 3 and 5 kW models)

3 More flexibility in design

- 60 °C water temperature
- Piping length improved: 7/9 kW: 50/30 m (up to 40 m without minimum floor area*) - 3/5 kW: 25/20 m
- Chiller function cooling down to 10 °C outdoor temperature

* With a 5 % decrease of the capacity.

4 New smart functions

- SG ready for heating, cooling and DHW modes
- Utility remote bivalent control: By dry contacts*
- Stop external device when defrost by Dry contact (for fan coil fan stop)*

* Can not be used at same time.

5 More comfort

- Better comfort in extreme low temperature: Heating curve can be set up down to -20 °C
- Efficient or comfort mode for DHW: Part load for better efficiency or full load to reduce the heat up time
- DHW two sensor position selectable for All in One: Efficient position (best DHW COP) or bigger volume of hot water

Other improvements: More silent outdoor units / Magnet filter for water cycle.

R32 refrigerant gas: A 'small' change that changes everything

Panasonic recommends R32 because it is comparably environmentally friendly. Compared to R22 and R410A, R32 has a very low potential impact on the depletion of ozone layer and global warming.

In line with the European countries who are concerned in protecting and maintaining the environment by participating in the Montreal Protocol to protect the Ozone Layer and prevent Global Warming, Panasonic is leading the switch to R32.

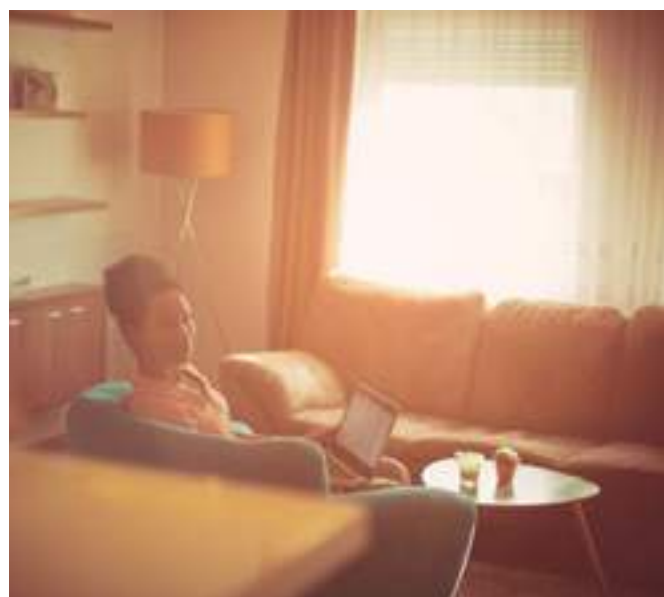

Aquarea H Generation.

The beauty of comfort. The H Generation is being introduced from 3 to 16 kW. The small capacities are specially designed for low energy homes and achieve an impressive COP of 5 (on the 3 kW).

Better Efficiency & Value A++/A+++.

- A++ for medium temperature applications (radiators. ErP 55 °C in the scale from A+++ to D)
- A+++ for low temperature applications (floor heating. ErP 35 °C in the scale from A+++ to D)

Aquarea, a generation of energy efficient heating and hot water.

Thanks to the system's high degree of technology and advanced control, it is able to maintain a high output capacity and efficiency even at -7 °C and -15 °C. The Aquarea's software can be set for the requirements of low consumption homes in order to maximise energy efficiency. Whatever the weather, Aquarea can work even at -28 °C (for T-CAP All in One and Bi-bloc) lower limit. The compact design of the outdoor unit makes installation very easy.

Aquarea All in One



Aquarea All in One: This range intelligently integrates the best Hydrokit technology with a premium quality stainless steel tank, which is maintenance-free.

Aquarea All in One: the best Panasonic technology for your home

All in One with U-Vacua insulation technology

Panasonic U-Vacua™ is a high performance vacuum insulation panel with very low thermal conductivity, that performs about 19 times better than standard urethane foam.

High quality components inside:

- Maintenance free Inox stainless 185 l tank
- Variable speed water pump (class A)
- Magnetic Filter with shut-off valves
- Expansion vessel
- Vortex flow sensor
- Back up heater
- Safety valve
- Air purge valves
- 3 way valve inside

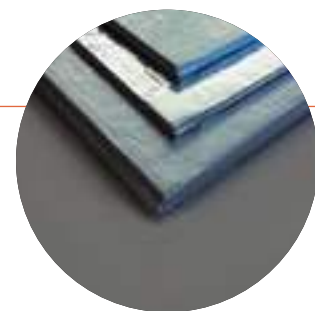

U-Vacua™ VIPs consist of a unique fiberglass core encased in a laminate film made up of several layers that include nylon, aluminium, and a protective layer. Interior pressure is reduced to a vacuum of 1-20 Pa, thereby minimising thermal conductivity.

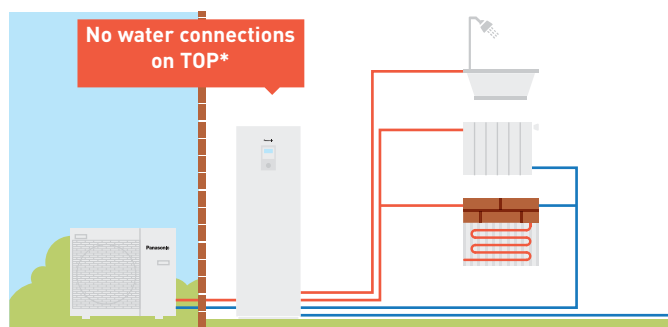

Technology to save space

Space-saving solutions, ideal for installations with restricted space.

- Hydrokit and tank in a single unit
- Water piping connections at the bottom, keeping more space above the unit free for use
- No buffer tank required
- Piping length up to 50 m (for J Generation 7 and 9 kW)
- Modern remote controller can be installed up to 50 m from the indoor unit

* Excluding 2 Zone model.

All in One, compact and easy to install

The Aquarea All in One belongs to the new generation of Panasonic heat pumps for heating, cooling and providing domestic hot water in the home.

Improved square design with white goods finish. Modern remote controller can be installed up to 50 m from the indoor unit.

Installer Friendly:

- Electrical connections is now located on front side
- Easy access to parts and easy to install by having all pipings in a row
- Remote controller with full dotted wide screen and new functions
- Can connect additional room temperature sensor, solar kit, 2 zones control, swimming pool and circulating pump (need optional PCB: CZ-NS4P)
- No buffer tank is required

All in One with 2 zones control.

- 2 heating circuits, with 2 different water temperatures
- 2 water pumps and 2 water filters
- Floor heating water control with mixing valve

2 Zones with control of 2 water temperatures (such as underfloor with water at 35 °C and radiators with water at 45 °C).

The new Aquarea All in One Compact unit is the ultimate space-saving solution.

Its 598 x 600 mm footprint, standard size of other big appliances, reduces the space required for the installation.

* 1 heating zone version available only.



Aquarea High Performance



For new installations and low consumption homes. Outstanding efficiency and energy savings with minimised CO₂ emissions and minimum space.

High Performance helps you to meet strict building requirements and reduce building costs

The heating and production of domestic hot water have a very important impact on the energy consumption of a house. Efficient Panasonic heat pumps can help to significantly reduce the energy consumption of the house.

Key points of the line-up

- Improved performance with COPs up to 5,33 for J Generation 3kW
- Reduced energy consumption through our circulating pump with energy efficiency class "A"
- Remote controller functions added: Auto mode, holiday mode, power consumption display

Panasonic has designed the Aquarea Bi-bloc and Mono-bloc heat pumps for homes which have high performance requirements. Whatever the weather, Aquarea can work even at -20 °C! The Aquarea is easy to install on new or existing installations, in all types of properties.

High Performance Heat Pumps are also highly efficient (take the KIT-ADC03JE5 for example)

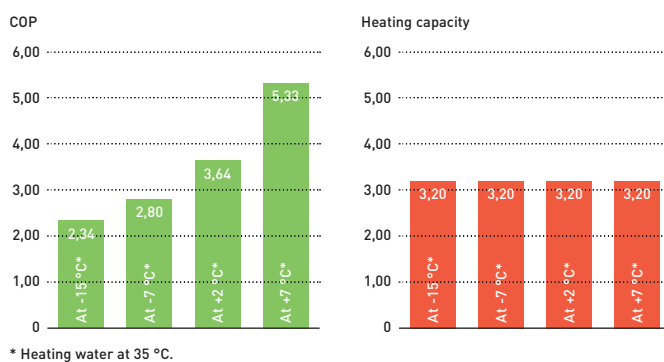

* Heating water at 35 °C.

Standard circulating pumps vs our circulating pump with energy efficiency class "A"

Comparison of energy consumption of circulation pumps. Circulating pump with energy efficiency class "A" with Dynamic flow control for 5 kW Mono-bloc.

* Based on German market: Assuming Standard pump may vary depending on consumption and energy cost.

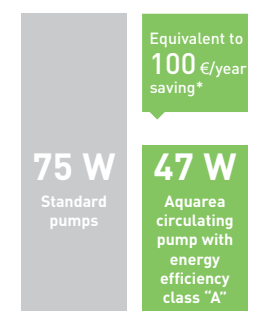

Panasonic created a night mode to reduce the noise when it's needed

Special attention has been given to noise levels.

- 1) Sound pressure measured at 1 m from the outdoor unit and at 1,5 m height.
- 2) At standard condition working at heating capacity at +7 °C (heating water at 35 °C) for two fans outdoor units. For one fan outdoor units, night mode reduction is 3 dB(A).

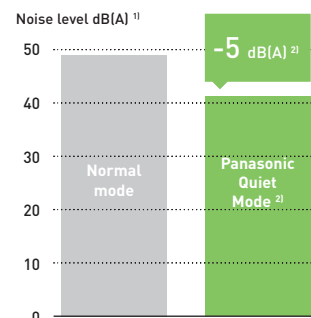

High Performance J Generation keeps 60 °C water outlet temperature even at very low temperatures

Aquarea High performance J Generation is able to keep 60 °C water outlet temperature in outdoor temperatures down to -10 °C, keeping high comfort in the room even at low temperatures. With other heat pumps, water temperature dramatically drops at low outdoor temperatures, making the heat pump to work out of the design conditions and creating discomfort inside the room.

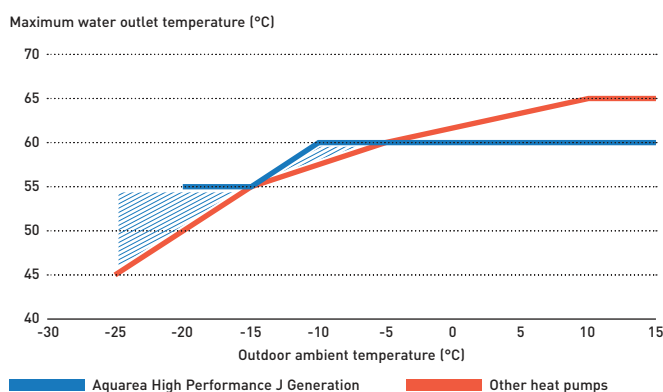

Aquarea T-CAP



For retrofit and new builds, install the T-CAP heat pump where the kW output capacity is demanding.

Ensure the heating capacity is maintained even at low temperatures

The entire Aquarea T-CAP lineup is excellent for replacing gas or oil boilers and for connecting to new underfloor heating, radiators or fan coil units. All Aquarea Heat

Pumps can also be connected to a solar thermal or PV system in order to increase efficiency and minimise environmental impact.

Higher efficiency compared to other heating systems

Panasonic heat pumps have a maximum COP of 4,85 at +7 °C which makes them much more efficient than others heating systems. T-CAP is also able to provide extremely high efficiencies, whatever the outside or the water temperature.

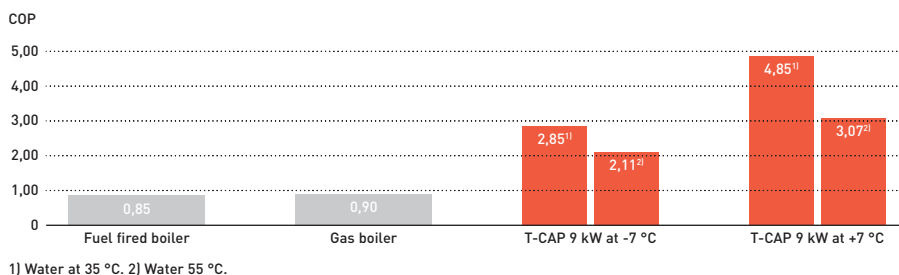

No need to oversize to reach required capacity at low temperatures

Panasonic heat pumps can work in outdoor temperatures as low as -28 °C and maintain capacity without backup heating at -20 °C¹⁾. With other heat pumps, a larger capacity is required to achieve the same level of comfort at low temperatures.

1) 35 °C flow temperature.

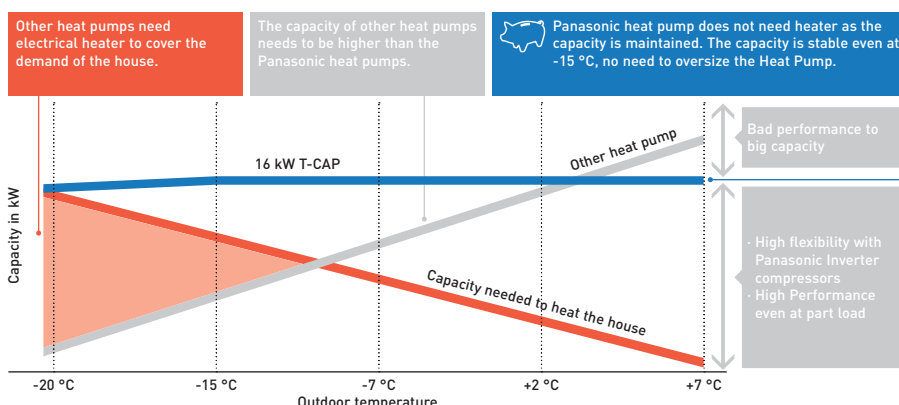

How Aquarea T-CAP maintains performance even at -20 °C outdoors

Thanks to effective refrigerant control via our unique dual-piped heat exchanger and bypass, Aquarea T-CAP provides stable heating even at -20 °C.

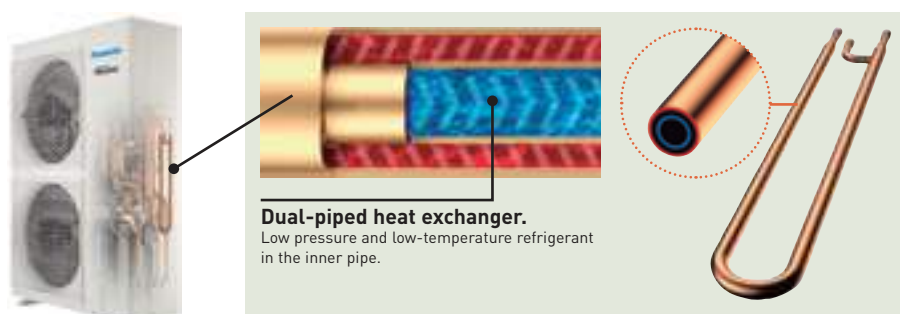

Aquarea Super Quiet T-CAP Bi-bloc

The special outdoor chassis notably reduces operation sound by up to 15 dB.^{1) 2)}

1) When comparing WH-UQ12HE8 at quiet mode level 3 operation with WH-UX12HE8 at full load operation.
2) Heating capacity may drop.

Key points of the line-up

- Ability to maintain the heat pump kW¹⁾ output capacity until -20 °C outdoor temperature without the help of an electrical booster heater
- High heating capacity even at low ambient temperatures
- Additional functions: Auto and holiday mode, boost, drying concrete and power consumption display
- 3/6/9 kW electrical heater is included in the heat pump (depending on unit)
- Cooling mode activation possible via software²⁾

1) At 35 °C flow. 2) This activation can only be done by service partner or installer.

Aquarea HT



Aquarea HT can produce a flow temperature of 65 °C making it the ideal high efficiency replacement for oil/gas boilers connected to high temperature radiators.

Green energy source works with existing radiators

The Aquarea HT (9 kW & 12 kW) allows you to replace your traditional heating source (such as oil or gas) while keeping the existing old style radiators for minimum disruption to the home.

Aquarea HT: High savings and low CO₂

The benefit of replacing a traditional heating systems with Aquarea HT are clear: Reduced CO₂ emissions, future proofing running costs. Panasonic heat pumps are much more efficient than fossil fueled boilers and help you to reach your house energy targets.

Yearly savings with Aquarea HT

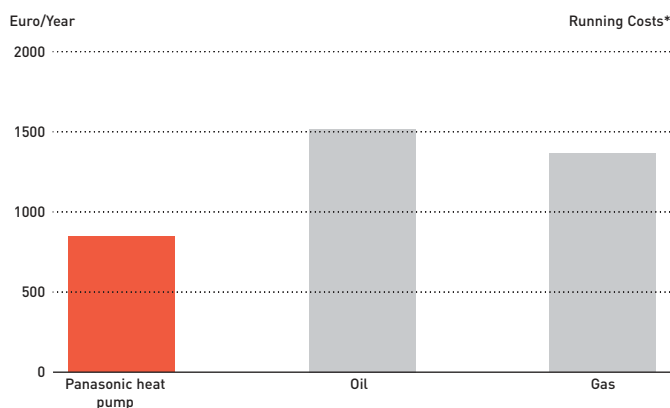

* For a 170 m² house and 40 W/m² energy losses in central Europe Conditions, outside minimum conditions -10 °C.

Smart Bivalent operation

Using the Aquarea bivalent controller, it is now possible to combine different heat sources (boiler with heat pump) allowing to set up the system to operate in the most efficient way.



Heat Pump + Boiler with DHW cylinder controlled by the smart bivalent controller.

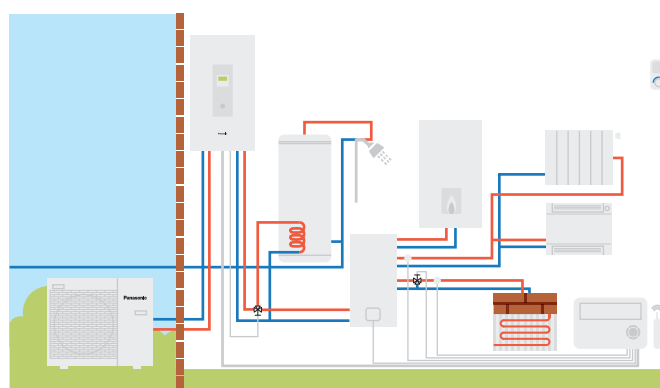

Easy installation

Air source heat pumps are simple to install. They do not require a chimney, gas connection or oil/lpg tank. All that is required is a power supply connection.

Panasonic Aquarea HT is highly efficient even at low outdoor temperatures

Heating Capacity of a 9 kW HT (WH-SHF09F3E5).

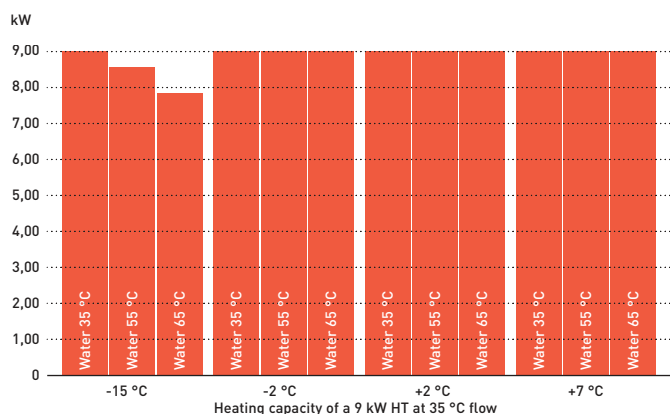

COP (Coefficient of Performance) of a 9 kW HT (WH-MHF09G3E5).

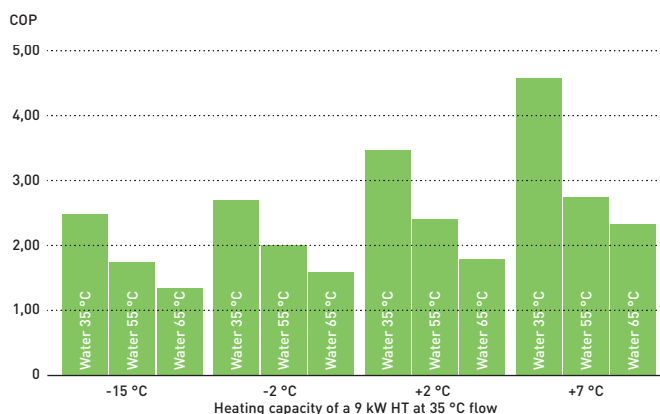

The Aquarea HT range is easy to install and is available with nominal heat outputs of 9 kW or 12 kW. These can be either single or three phase, in both Bi-bloc and Mono-bloc versions.

Aquarea commercial

Restaurant with Aquarea

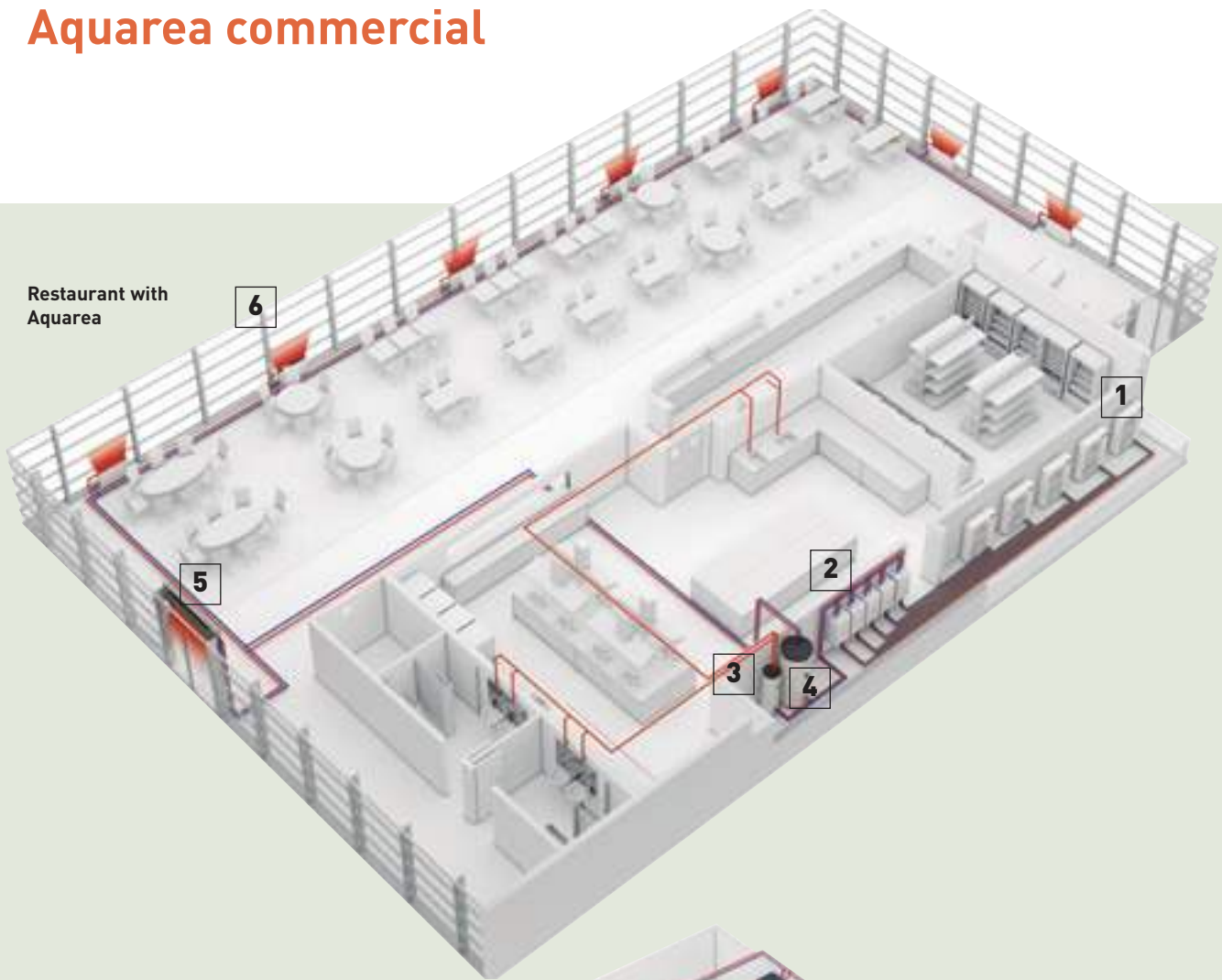

Supermarket with Aquarea

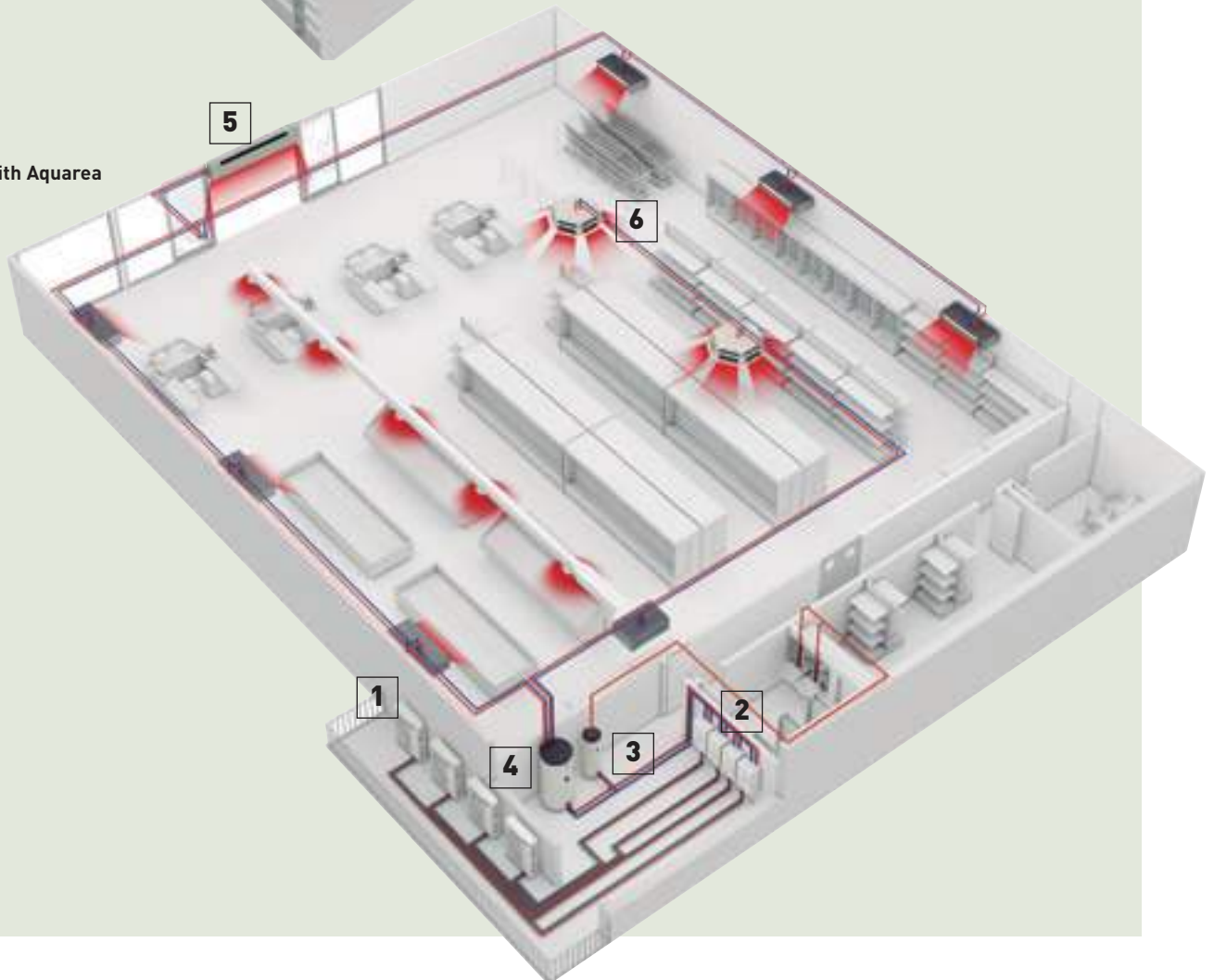

Solutions for best savings. Efficient Panasonic heat pumps can help to significantly reduce the energy consumption of your business.

Panasonic Aquarea Heat Pumps offer space saving, energy-efficient heating and can be easily adapted for installation in flats, houses and commercial premises. Businesses producing heating, cooling and big quantities of hot water at 65 °C, such as restaurants or supermarkets, installing an Aquarea Heat Pump system can also use this wasted heat to improve energy efficiency further.

Heat pump technology is scalable, meaning that it can be installed in buildings of varying sizes, offering both small and large-scale heating solutions. The technology is also environmentally friendly when compared to traditional

heating systems alternatives based on fossil fuel energy and in addition it is more energy efficient.

Key points:

- Efficient hot water production
- Fast return of investment
- Easy control
- Easy integration in the existing water system: fan coils, floor heating, domestic hot water tanks, etc
- Very good part load management
- High efficiency



1
Aquarea T-CAP.
16 kW heat pumps on cascade mode. T-CAP line-up is an ideal replacement for old gas/oil boilers



2
High efficiency Aquarea T-CAP hydromodule.
Indoor unit of Aquarea Bi-bloc systems. When a Mono-bloc system is used, the hydromodule is integrated in the outdoor unit.



3
Super high efficiency Tanks.
Combining Panasonic Aquarea with a high efficiency tank ensures the desired volume of hot water, at the correct temperature while reduced energy costs.



4
Buffer Tank.
Panasonic Aquarea can be combined with the hydraulic elements of the new or existing water system.



5
Air Curtain with water Coil.
Water coil air curtains can be used in the hydraulic system to have efficient performance of the water system.



6
Fan coils for heating and cooling.
Aquarea heat pumps can be easily connected to the existing water system: 2 way and 4 way fan coils, floor heating, DHW tanks...



7
Cascade manager.
The Cascade manager enables the control of up to 10 Aquarea heat pumps (balancing the working hours and making the operation more efficient) and up to 2 buffer tanks.

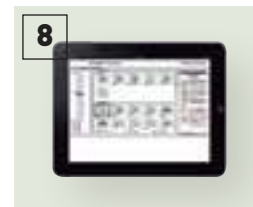

8
BMS integration.
The cascade system can be easily integrated in a Modbus project thanks to the Cascade manager.



Burger & Lobster restaurant. Bath, UK.
Panasonic's air-to-water Aquarea system has been installed in the latest glamorous Burger & Lobster restaurant in Bath. The Octagon Chapel, a large listed building in the city centre, was converted to accommodate the restaurant, and Panasonic's Aquarea system provided an extensive, energy efficient and unobtrusive heating and cooling solution.



Carluccio's restaurant. UK
One of UK's leading Italian restaurant, Carluccio's, wanted to install a system which would provide the desired volume of hot water, at the correct temperature while at the same time reduced energy costs. FWP installed a 12 kW Aquarea T-CAP mono bloc unit which would allow for the free air from the kitchen roof space to be transferred through condensing unit providing hot water at the optimum temperature.

Aquarea Smart Cloud for end users

The most advanced heating control for today and for the future. Aquarea can be connected to the Cloud with CZ-TAW1, enabling both end user control and remote maintenance by service partners.

WATCH DEMO ▶



Easy and powerful energy management

The Aquarea Smart Cloud is much more than a simple thermostat for switching a heating device ON or OFF. It is a powerful and intuitive service for remotely controlling the full range of heating and hot water functions, including monitoring energy consumption.

How does it work?

After connecting an Aquarea J or H generation to the cloud by wireless LAN or by wired LAN, the user accesses the Cloud portal to remotely operate all functions of his units. He can also permit service partners to access customised functions for remote maintenance and monitoring.



* User interface image may change without notification.

Requirements

1. Aquarea J or H Generation
2. In-house internet connection with router wireless LAN or wired LAN
3. Get a Panasonic ID in <https://aquarea-smart.panasonic.com/>

Functions:

- Visualization and Control
- Scheduling
- Energy Statistics
- Malfunction notification



More possibilities with IFTTT.

IF This Then That: IFTTT service enables user to automatically trigger actions for Aquarea system based on other apps, web services or devices.

Connect your Aquarea to your voice assistant, get an e-mail if your Aquarea gets an error or automatically turn on your Aquarea on Heat Mode when outdoor temperature drops below specified level.

Advantages

Energy savings, comfort and control from anywhere. Increased efficiency and resources management, operating costs savings and owner satisfaction. The Aquarea Smart Cloud services are focused on enabling full remote maintenance of the Aquarea system. This allows maintenance specialists to engage in predictive maintenance and system fine-tuning, as well as fixing malfunctions when they occur.

| | |
|--|----------------------------------|
| Aquarea compatibility | J and H Generation |
| Connection point | CN-CNT Aquarea port |
| Home router connection | Wireless or Wired LAN |
| Temperature sensor | Can use remote controller sensor |
| Tablet or PC browser compatibility* | Yes |
| Operation from remote — ON/OFF — Temperature setting Mode selection — DHW setting — Error codes — Scheduling | Yes |
| Heating areas | Up to 2 zones |
| Power consumption estimation — Operation log history | Yes — Yes |

* Check browsers and version compatibility.

Aquarea Service Cloud for Installers / Maintenance

WATCH DEMO ▶



The real remote maintenance made simple

The Aquarea Service Cloud allows installers to take care of their customers' heating systems remotely. It saves time and money and shortens the response time, thus increasing the customers' satisfaction.

Advanced functions for remote maintenance with professional screens:

- Global view at a glance
- Error log history
- Full unit information
- Statistics always available
- Most settings available

Home page.

Status of connected users at a glance. 2 view options: map view or list view.



Status tab.

Current status of unit with a maximum 28 parameters.



Statistics tab.

Customisable statistics of a maximum of 71 parameters. Available anytime with the information of the last 7 days.

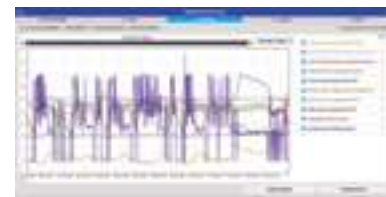

Settings tab.

Most of the user and installer settings can be done remotely.



Activation of the Aquarea Service Cloud

Requirements.

| Hardware and connection | End user registration | Installer / maintenance registration |
|---|-----------------------|--------------------------------------|
| J or H Generation Aquarea connected to CZ-TAW1 | Get Panasonic ID | Get Service ID |
| In-house internet connection with Wireless LAN or Wired LAN | Aquarea Smart Cloud | Aquarea Service Cloud |

Connecting the unit to the Aquarea Service Cloud.

The process can be initiated by the end user or by the installer.

The end user can select and change the installer's level of control anytime (4 levels).

Installer registration: <https://aquarea-service.panasonic.com/>

End user registration: <https://aquarea-smart.panasonic.com/>

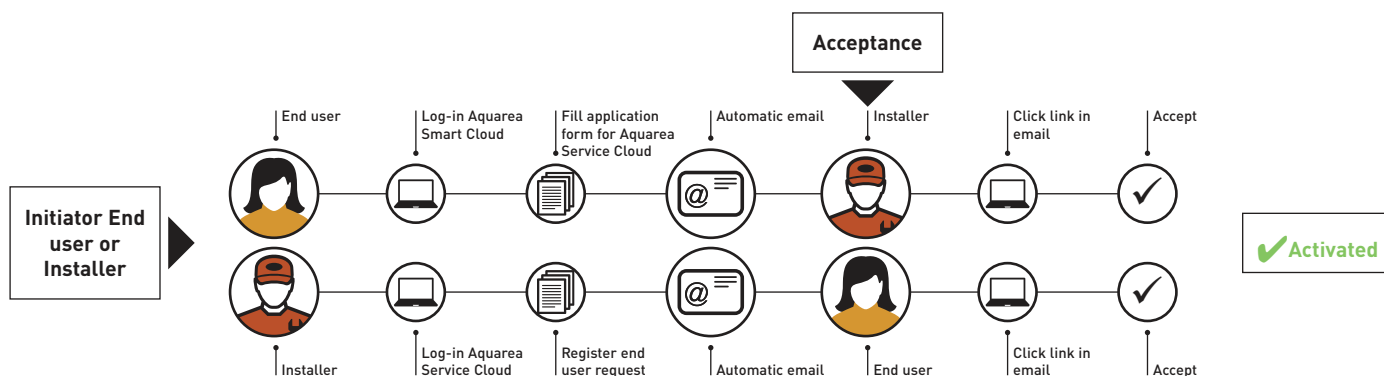

Control and Connectivity

Home connectivity and Home Managements Systems integration is becoming more and more popular.

These integrations helps to control all house devices from centralised platform and helps to optimise the operation and running costs. Panasonic interfaces are made to work with both KNX and Modbus, the most populars protocols. Also for non integrated control, Panasonic developed a simple connection to Wireless LAN, with this End User can control remotely its own heat pump from wherever.

Connectivity. Control by BMS

Great flexibility for integration into your KNX / Modbus projects allows fully bi-directional monitoring and control of all the functioning parameters.

| Reference |  PAW-AW-KNX-1i / PAW-AW-KNX-H | Modbus® PAW-AW-MBS-1 / PAW-AW-MBS-H |
|--|--|---|
| Small dimensions | ✓ | ✓ |
| Quick installation and possibility of hidden installation | ✓ | ✓ |
| External power not required | ✓ | ✓ |
| Direct connection to the unit | ✓ | ✓ |
| Control and monitoring, from sensors or gateways, of the internal variables of the indoor unit and error codes and indication | ✓ Fully interoperable | |
| Control and monitoring, from any BMS or PLC Modbus Master, of internal variables of the indoor unit and error codes and indication | | ✓ Fully interoperable |
| Aquarea unit can be controlled simultaneously by its remote controller and by KNX / Modbus Master devices | ✓ | ✓ |

These interfaces allows full monitoring and control, bi-directional, of most of the functioning parameters of Aquarea control from KNX / Modbus installations.

Advanced controller for J and H Generation



Improved visibility & Easy operation with large full dot LCD display and large touch panel!

Remote controller can be removed from indoor unit and installed in living room.

Function for installer:

- Floor heating concrete dry mode: Allows for a slow increase in temperature of underfloor heating via software.
- Heating and Cooling Mode: Authorised PRO Partners can enable the cooling mode through a special operation via the remote controller on site
- Installer can select delta T. Water pump speed is selected automatically due to this setting

Key Points:

Full large dot LCD screen (3,5 inch): High resolution screen with backlight, easy set up, check conditions easily, flat, innovative design, temperature sensor included in controller.

Function for End User:

- Auto Mode: Automatically changes from heating to cooling depending on outdoor temperature.
- Energy Consumption Display: Displays the heat pump's energy consumption, split by heating, cooling and domestic hot water, showing the total consumption figure.
- Holiday Mode: Enables the system to resume at the preset temperature after your holiday

Cascade Controller PAW-A2W-CMH



Cascade up to 10 Aquarea J or H Generation*.

- Up to 10 HP (working hour balancing)
- 3x M-BUS devices connectable (for heat meter and/or current meter)
- Demand PV functions (similar to HPM + 0-10 V demand signal control function)

- Can control 3 way valves for cooling (2 buffer tanks)
- MODBUS IP for BMS communication
- DHW control logic
- Touch display with information about the HP
- All components in one case

* Requires 1 PAW-AW-MBS-H per each Aquarea.

| Model name | Interface |
|---------------|---|
| PAW-AW-KNX-H | KNX Interface for J and H Generation |
| PAW-AW-MBS-H | Modbus Interface for J and H Generation |
| PAW-AW-KNX-1i | KNX interface (not compatible with J and H Generation) |
| PAW-AW-MBS-1 | Modbus interface (not compatible with J and H Generation) |

| Model name | Interface |
|-------------|--|
| PAW-A2W-CMH | Cascade controller. |
| CZ-TAW1 | Aquarea Smart Cloud, internet control through wireless or wired LAN for Aquarea J and H generation |

Aquarea + PV Panels

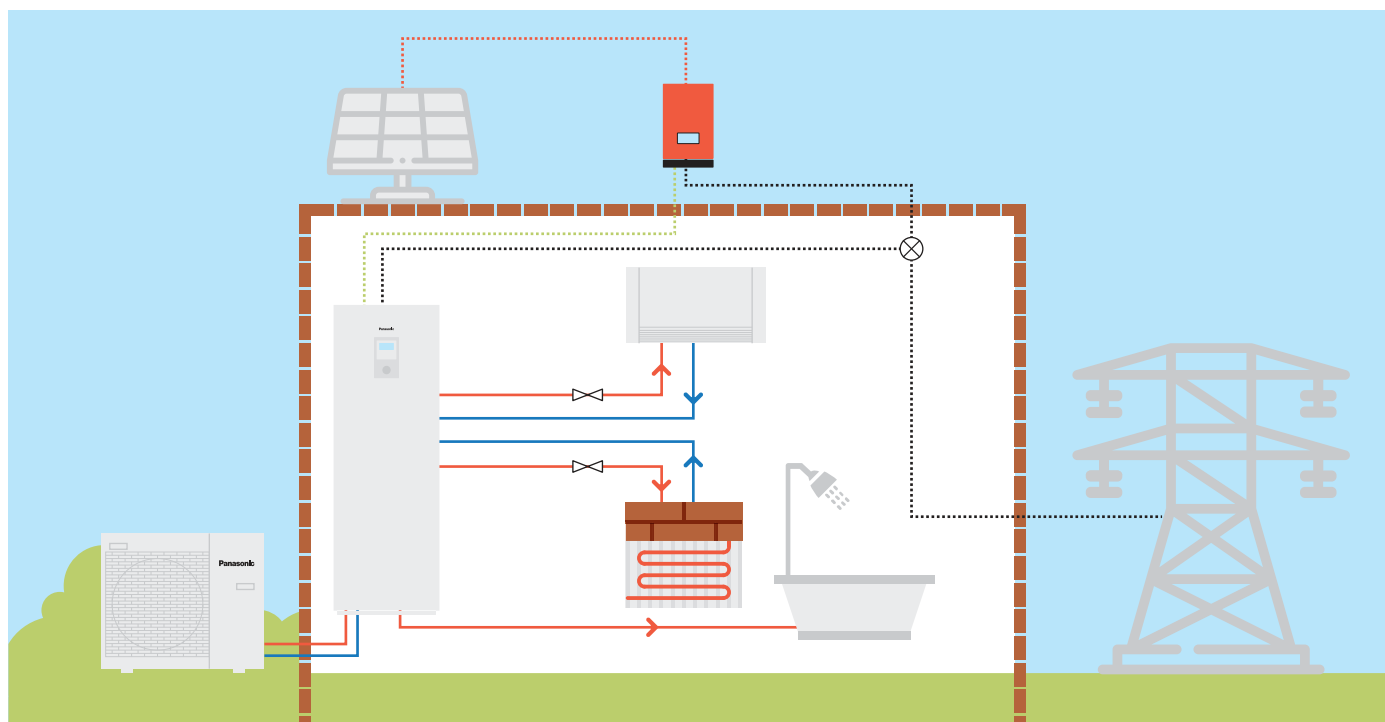

Aquarea heat pumps are designed with the future in mind. They can synchronise with PV panels with simple CZ-NS4P PCB. Thanks to this feature, demand of heating, cooling and domestic hot water production is adapted to the PV panel production.

A part of converting Aquarea in Smart Grid ready, the additional PCB allows 0-10V control, for and advanced energy management.

How Panasonic contributes to Nearly Zero Energy Buildings (NZEB)

Panasonic is committed to develop products with greater energy efficiency.

Our expertise gained over the years has helped to launch a range of products that contribute to a more carbon-free society.

Highly efficient Panasonic solutions can help to significantly reduce the energy consumption of the house:

- Aquarea High performance heat pump for heating, cooling and domestic hot water production
- Aquarea Smart Cloud, for energy monitoring
- Heat recovery ventilation system
- PV panels to produce renewable energy on-site



H3 Grande Passive House, Poland.

When looking for a energy-efficient heating solution, Polish construction company Procyon selected a 5 kW Panasonic Aquarea High Performance heat pump for its passive house project, H3 Grande. Procyon found this solution reduced annual heating expenses by almost half compared to an oil-based system, or by 10 % in comparison to natural gas.

H3 Grande is a 175 m² detached house certified by the Passive House Institute (PHI) in Darmstadt. It is designed to minimise energy losses while incorporating an attractive, yet simple aesthetic. The building's shape, interior design and pitched roof contribute to the energy balance of the house, while large south-facing windows and wall insulation provide passive thermal comfort by retaining heat. The building has very low heating demand of approximately 15 kW/m² and is designed to minimise energy.

Panasonic PRO Club makes your life easier. All Aquarea design tools can be found there



Energy Label

Fridges, dishwashers, washing machines, ovens – it all started with white goods in the 1990s. Today, other energy-consuming appliances also carry the European energy efficiency label, such as televisions and lighting. From 2013, the regulations applied to air conditioners and heat pumps but since September 2015, it has also been applicable to room heaters, water heaters and storage water heaters.

Minimum energy efficiency requirements are also specified for manufacturers of system and combi boilers, water heaters and DHW cylinders.

The purpose of Energy Labels are to assist consumers in their purchasing decisions, as well as ecodesign requirements on products which help reduce private energy demand and help to reduce global warming.

Panasonic helps you to calculate the system label.

From 26th September 2015, installers can be assured that all products manufactured after this date will be sold with the required energy efficiency labels which will aid installers with their paperwork. While it is the manufacturer's responsibility to issue their products with the required labels, the installers will need to calculate and issue an energy efficiency label for the entire heating system. Whether installing a new heating system or installing new boilers, controls or renewables into an existing system, it is, and will continue to be, the installer's responsibility to calculate and issue energy efficiency labels. Calculators which assist installers with this process are available on www.panasonicproclub.com.

Information on the energy efficiency label.

The rating system for heat pumps classifies them into seven efficiency categories. From 26th September 2019, the best energy efficiency category is A+++ (least energy efficient is D). The energy efficiency label for system boilers shows its efficiency category on a scale from A+++ to D, and from A+ to F for hot water cylinders.

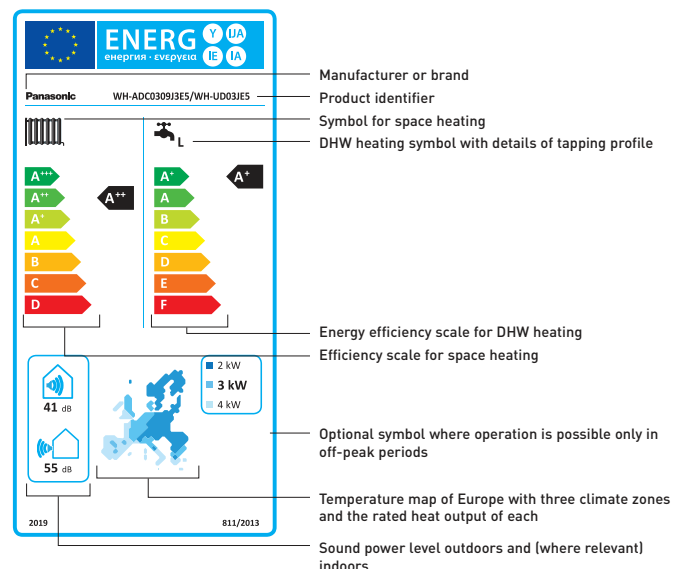

Aquarea design tools

Aquarea Designer

This program allows HVAC designers, installers and distributors to identify the correct heat pump for a particular application from Panasonic's Aquarea range, calculate the savings compared to other heat sources and very quickly calculate CO₂ emissions.

Using Panasonic's Aquarea Designer, projects can be developed simply and easily, by either using the Quick Design or Expert Design options. Each allows the user to build up the project data in a simple step-by-step process and choose to output reports (project data input includes: either Quick or Large formats) as HTML files or as print-outs. To create these useful reports, project data is input, including:

- Heated area
- Heating requirement
- Heating flow and return temperatures
- Climate data (from a simple drop-down menu) including outdoor temperature
- Type of hot water tank, storage capacity and hot water target temperature



Aquarea Designer also means saving

Aquarea Designer will calculate the project's energy costs in terms of hot water, heating and pumping. It will show the equipment running times and calculate the COP (coefficient of performance). It then allows the designer to show clients a comparison with other equipment options such as heating by conventional gas-fired boilers, oil systems, wood, standard electric heating and electric night storage heaters. This compares running costs, initial investment costs and maintenance costs. The comparison can also be made for CO₂ emissions and savings.

Panasonic provides bespoke software helping system designers, installers and dealers to very quickly design and size systems, create wiring diagrams and issue bills of quantities at the push of a button.

Heating demand calculator

This software can quickly and easily determine the heating requirements for the rooms in a project. The Heating demand calculator will help determine approximately how much power is needed to heat each room individually. The result in kilowatts will help you choose the space heater best suited to your needs.

CAD images and spec texts

In order to add value in the design of projects, Panasonic has a wide library of 2D CAD, BIM objects (Building Information Modeling) and Spec texts to be used in Revit.

Panasonic has an impressive range of support services for designers, specifiers, engineers and distributors working in air-to-water heat pump projects.

All the support tools are available in Panasonic PRO Club (www.panasonicproclub.com).

Among many others, these are the main tools for the design of Aquarea projects.

Panasonic helps you to calculate the system label www.panasonicproclub.com or connect simply with your smartphone to the PRO Club using this QR.

Hydraulic scheme generator



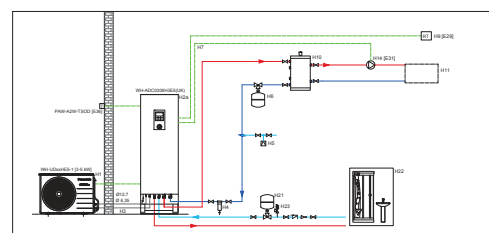













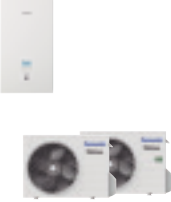
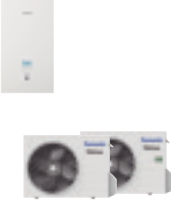

This tool allows customers to select the scheme between more than 110 different type according to their installation requirements in a simple way. It possible to download hydraulic and electric part in pdf and in cad file. Moreover it is available a list, one for each scheme type, with the Panasonic codes and third party codes that the customers need to realize the installation in a proper way.





PRO Club  



Aquarea Heat Pumps Line-Up

| | | 3 kW | 5 kW | 7 kW |
|---------------------------------|---|---|---|---|
| Aquarea High Performance | All in One 1 Phase 3 Phase |  WH-ADC0309J3E5 WH-ADC0309J3E5B WH-UD03JE5 WH-ADC0309H3E5 WH-ADC0309H3E5B WH-UD03HE5-1 |  WH-ADC0309J3E5 WH-ADC0309J3E5B WH-UD05JE5 WH-ADC0309H3E5 WH-ADC0309H3E5B WH-UD05HE5-1 |  WH-ADC0309J3E5 WH-ADC0309J3E5B WH-UD07JE5 WH-ADC0309H3E5 WH-ADC0309H3E5B WH-UD07HE5-1 |
| P. 48, 52, 53 |  | | | |
| P. 49 | NEW All in One Compact 1 Phase |  WH-ADC0309J3E5C ¹⁾ WH-UD03JE5 |  WH-ADC0309J3E5C ¹⁾ WH-UD05JE5 |  WH-ADC0309J3E5C ¹⁾ WH-UD07JE5 |
| |  | | | |
| P. 50, 56, 57 | Bi-bloc 1 Phase 3 Phase |  WH-SDC0305J3E5 WH-UD03JE5 WH-SDC03H3E5-1 WH-UD03HE5-1 |  WH-SDC0305J3E5 WH-UD05JE5 WH-SDC05H3E5-1 WH-UD05HE5-1 |  WH-SDC0709J3E5 WH-UD07JE5 WH-SDC07H3E5-1 WH-UD07HE5-1 |
| |  | | | |
| P. 51, 60 | Mono-bloc 1 Phase | |  NEW WH-MDC05J3E5 ²⁾ WH-MDC05H3E5 |  NEW WH-MDC07J3E5 ²⁾ WH-MDC07H3E5 |
| |  | | | |
| Aquarea T-CAP | All in One 1 Phase 3 Phase | | | |
| P. 54, 55 |  | | | |
| P. 58, 59 | Bi-bloc 1 Phase 3 Phase | | | |
| |  | | | |
| P. 61 | Mono-bloc 1 Phase 3 Phase | | | |
| |  | | | |
| Aquarea HT | Bi-bloc 1 Phase 3 Phase | | | |
| P. 62 |  | | | |
| P. 63 | Mono-bloc 1 Phase | | | |
| |  | | | |

 Heating,  Cooling,  DHW. WH-__E5 1 Phase // WH-__E8 3 Phase. Green references refer to R32 models. 1) Available in Autumn 2020. 2) Available in May 2020.

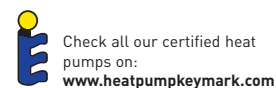

9 kW



WH-ADC0309J3E5
 WH-ADC0309J3E5B
 WH-UD09JE5-1
 WH-ADC0309H3E5
 WH-ADC0309H3E5B
 WH-UD09HE5-1
 WH-ADC0916H9E8
 WH-UD09HE8

12 kW

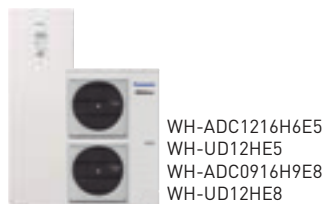

WH-ADC1216H6E5
 WH-UD12HE5
 WH-ADC0916H9E8
 WH-UD12HE8

16 kW

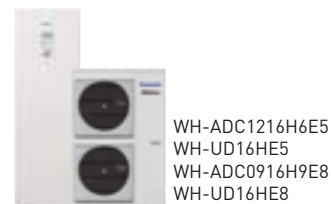

WH-ADC1216H6E5
 WH-UD16HE5
 WH-ADC0916H9E8
 WH-UD16HE8



WH-ADC0309J3E5C ¹⁾
 WH-UD09JE5-1



WH-SDC0709J3E5
 WH-UD09JE5-1
 WH-SDC09H3E5-1
 WH-UD09HE5-1
 WH-SDC09H3E8
 WH-UD09HE8

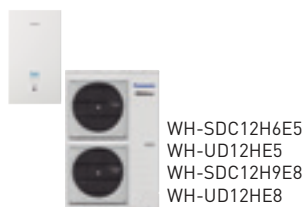

WH-SDC12H6E5
 WH-UD12HE5
 WH-SDC12H9E8
 WH-UD12HE8

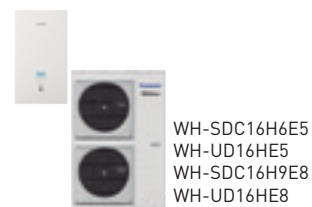

WH-SDC16H6E5
 WH-UD16HE5
 WH-SDC16H9E8
 WH-UD16HE8



NEW
 WH-MDC09J3E5 ²⁾

WH-MDC09H3E5



WH-MDC12H6E5



WH-MDC16H6E5

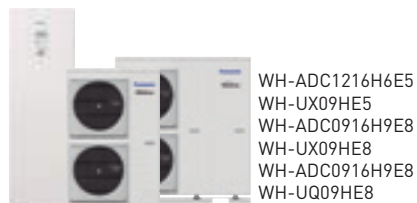

WH-ADC1216H6E5
 WH-UX09HE5
 WH-ADC0916H9E8
 WH-UX09HE8
 WH-ADC0916H9E8
 WH-UQ09HE8

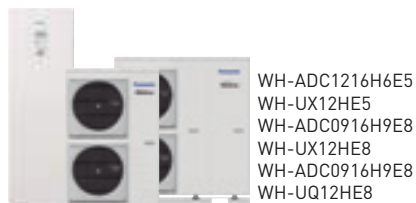

WH-ADC1216H6E5
 WH-UX12HE5
 WH-ADC0916H9E8
 WH-UX12HE8
 WH-ADC0916H9E8
 WH-UQ12HE8

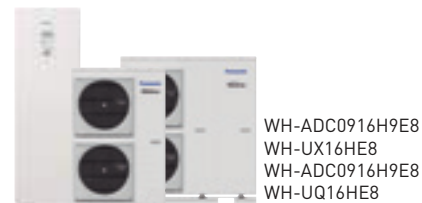

WH-ADC0916H9E8
 WH-UX16HE8
 WH-ADC0916H9E8
 WH-UQ16HE8



WH-SXC09H3E5
 WH-UX09HE5
 WH-SXC09H3E8
 WH-UX09HE8
 WH-SQC09H3E8
 WH-UQ09HE8

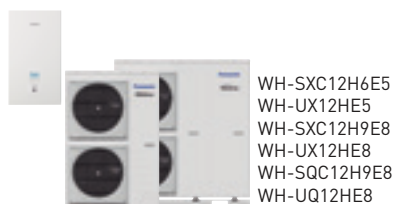

WH-SXC12H6E5
 WH-UX12HE5
 WH-SXC12H9E8
 WH-UX12HE8
 WH-SQC12H9E8
 WH-UQ12HE8



WH-SXC16H9E8
 WH-UX16HE8
 WH-SQC16H9E8
 WH-UQ16HE8



WH-MXC09H3E5
 WH-MXC09H3E8



WH-MXC12H6E5
 WH-MXC12H9E8



WH-MXC16H9E8

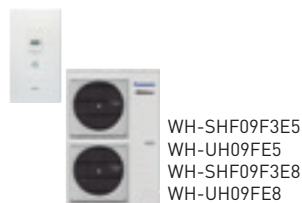

WH-SHF09F3E5
 WH-UH09FE5
 WH-SHF09F3E8
 WH-UH09FE8

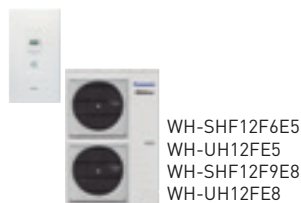

WH-SHF12F6E5
 WH-UH12FE5
 WH-SHF12F9E8
 WH-UH12FE8



WH-MHF09G3E5



WH-MHF12G6E5

Aquarea High Performance All in One J Generation Single Phase. Heating and Cooling 1 or 2 zones

- R32 refrigerant



Technical focus

Top level COP 5,33 — Reduced installation costs — Piping at the bottom of the All in One (easy to install) — Reduced installation time and minimised installation errors — Easy remote controller to set up — Reduced installation spaces — Electrical connections at the front — Easier installation and maintenance — Remote controller functions (cooling mode activation possible by software. This activation can only be done by service partner)



CZ-TAW1
Cloud connection.
For user control and installer remote maintenance.

| Tentative Data | | Single Phase (Power to indoor) | | | |
|--|-----------------------|--------------------------------|--------------------------|--------------------------|--------------------------|
| Kit* 1 zone (for 2 zone add B at the end) | | KIT-ADC03JE5 | KIT-ADC05JE5 | KIT-ADC07JE5 | KIT-ADC09JE5-1 |
| Heating capacity / COP [A +7 °C, W 35 °C] | kW / COP | 3,20/5,33 | 5,00/5,00 | 7,00/4,76 | 9,00/4,48 |
| Heating capacity / COP [A +7 °C, W 55 °C] | kW / COP | 3,20/2,81 | 5,00/2,72 | 7,00/2,82 | 8,95/2,78 |
| Heating capacity / COP [A +2 °C, W 35 °C] | kW / COP | 3,20/3,64 | 4,20/3,18 | 6,85/3,41 | 7,00/3,40 |
| Heating capacity / COP [A +2 °C, W 55 °C] | kW / COP | 3,20/2,19 | 4,10/1,99 | 6,20/2,21 | 6,30/2,16 |
| Heating capacity / COP [A -7 °C, W 35 °C] | kW / COP | 3,30/2,80 | 4,20/2,59 | 5,60/2,87 | 6,12/2,78 |
| Heating capacity / COP [A -7 °C, W 55 °C] | kW / COP | 3,20/1,79 | 3,55/1,71 | 5,25/1,94 | 5,90/1,93 |
| Cooling capacity / EER [A 35 °C, W 7 °C] | kW / EER | 3,20/3,52 | 4,50/3,00 | 6,70/3,03 | 8,20/2,72 |
| Cooling capacity / EER [A 35 °C, W 18 °C] | kW / EER | 3,20/4,85 | 4,80/4,29 | 6,70/4,72 | 9,00/4,18 |
| Seasonal energy efficiency - Heating average climate (W35 °C / W55 °C) | ηs % | 200/136 | 200/136 | 193/130 | 193/130 |
| | SCOP | 5,07/3,47 | 5,07/3,47 | 4,90/3,32 | 4,90/3,32 |
| Energy class heating average climate (W35 °C / W55 °C) ¹⁾ | A+++ to D | A+++ / A++ | A+++ / A++ | A+++ / A++ | A+++ / A++ |
| Seasonal energy efficiency - Heating warm climate (W35 °C / W55 °C) | ηs % | 245/165 | 245/165 | 227/160 | 227/160 |
| | SCOP | 6,20/4,20 | 6,20/4,20 | 5,75/4,07 | 5,75/4,07 |
| Energy class heating warm climate (W35 °C / W55 °C) ¹⁾ | A+++ to D | A+++ / A+++ | A+++ / A+++ | A+++ / A+++ | A+++ / A+++ |
| Seasonal energy efficiency - Heating cold climate (W35 °C / W55 °C) | ηs % | 157/110 | 157/110 | 164/116 | 164/116 |
| | SCOP | 4,00/2,83 | 4,00/2,83 | 4,18/2,98 | 4,18/2,98 |
| Energy class heating cold climate (W35 °C / W55 °C) ¹⁾ | A++ to D | A++ / A+ | A++ / A+ | A++ / A+ | A++ / A+ |
| Indoor unit 1 zone hydrokit | | WH-ADC0309J3E5 | WH-ADC0309J3E5 | WH-ADC0309J3E5 | WH-ADC0309J3E5 |
| Indoor unit 2 zones built-in hydrokit | | WH-ADC0309J3E5B | WH-ADC0309J3E5B | WH-ADC0309J3E5B | WH-ADC0309J3E5B |
| Sound pressure | Heat / Cool | 28/28 | 28/28 | 28/28 | 28/28 |
| Dimension | HxWxD | 1800x598x717 | 1800x598x717 | 1800x598x717 | 1800x598x717 |
| Net weight 1 zone / 2 zones | | 122/130 | 122/130 | 122/130 | 122/130 |
| Water pipe connector | | R 1½ | R 1½ | R 1½ | R 1½ |
| A class pump | Number of speeds | Variable Speed | Variable Speed | Variable Speed | Variable Speed |
| | Input power (Min/Max) | W | 30/120 | 30/120 | 30/120 |
| Heating water flow [ΔT=5 K, 35 °C] | | L/min | 9,20 | 14,30 | 20,10 |
| Capacity of integrated electric heater | | kW | 3,00 | 3,00 | 3,00 |
| Recommended fuse | | A | 16/16 | 25/16 | 25/16 |
| Recommended cable size, supply 1 / 2 | | mm² | 3x1,5/3x1,5 | 3x1,5/3x1,5 | 3x2,5/3x1,5 |
| Water volume | | L | 185 | 185 | 185 |
| Maximum water temperature | | °C | 65 | 65 | 65 |
| Material inside tank | | Stainless steel | Stainless steel | Stainless steel | Stainless steel |
| Tapping profile according EN16147 | | L | L | L | L |
| DHW tank ERP average climate efficiency rating ²⁾ | A+ to F | A+ | A+ | A+ | A+ |
| DHW tank ERP warm climate efficiency rating ²⁾ | A+ to F | A+ | A+ | A+ | A+ |
| DHW tank ERP cold climate efficiency rating ²⁾ | A+ to F | A | A | A | A |
| DHW tank ERP average climate η / SCOP | ηwh % / SCOP | 132/3,30 | 132/3,30 | 120/3,00 | 120/3,00 |
| DHW tank ERP warm climate η / SCOP | ηwh % / SCOP | 155/3,88 | 155/3,88 | 140/3,50 | 140/3,50 |
| DHW tank ERP cold climate η / SCOP | ηwh % / SCOP | 99/2,48 | 99/2,48 | 99/2,47 | 99/2,47 |
| Outdoor unit | | WH-UD03JE5 | WH-UD05JE5 | WH-UD07JE5 | WH-UD09JE5-1 |
| Sound power part load ³⁾ | Heat | 55 | 55 | 59 | 59 |
| Sound power full load | Heat / Cool | 60/61 | 64/64 | 68/67 | 69/69 |
| Dimension / Net weight | HxWxD | mm / kg | 622x824x298/37 | 622x824x298/37 | 795x875x320/61 |
| Refrigerant (R32) / CO ₂ Eq. | | kg / T | 0,9/0,608 | 0,9/0,608 | 1,27/0,857 |
| Pipe diameter | Liquid / Gas | Inch [mm] | 1/4 [6,35] / 1/2 [12,70] | 1/4 [6,35] / 1/2 [12,70] | 1/4 [6,35] / 5/8 [15,88] |
| Pipe length range / Elevation difference (in/out) | | m / m | 3~25/20 | 3~25/20 | 3~50/30 |
| Pipe length for additional gas / Additional gas amount | | m / g/m | 10/20 | 10/20 | 10/25 |
| Operation range | Outdoor ambient | °C | -20~+35 | -20~+35 | -20~+35 |
| Water outlet | Heat / Cool | °C | 20~60/5~20 | 20~60/5~20 | 20~60/5~20 |

Accessories (optional)

| | |
|-------------------------|--|
| PAW-ADC-PREKIT-1 | Piping pre installation kit for J Generation |
| PAW-ADC-CV150 | Decorative magnetic side cover |
| CZ-TAW1 | Aquarea Smart Cloud for remote control and maintenance through wireless or wired LAN |

Accessories (optional)

| | |
|----------------------------|------------------------------|
| CZ-NS4P | Additional functions PCB |
| PAW-A2W-RTWIRED | Room thermostat |
| PAW-A2W-RTWIREDLESS | Wireless LCD room thermostat |

1) Scale from A+++ to D. 2) Scale from A+ to F. 3) Sound power in accordance to 8112013,81312013 and EN12102-1:2017 at +7 °C.

EER and COP calculation is based in accordance to EN14511.

This product is designed to comply with the European Water Quality Directive 98/83/EC amended by 2015/1787/EU. The lifespan of the product is not guaranteed in the case of the use of groundwater, such as spring water or well water, the use of tap water when salt or other impurities are contained, nor in areas of acidic water quality. Maintenance and warranty costs related to these cases are the customer's responsibility.



INTERNET CONTROL: Optional. GOOD DESIGN AWARD 2017: Indoor units All in One and Bi-bloc H Generation awarded with the prestigious Good Design Award 2017.

New Aquarea High Performance All in One Compact J Generation Single Phase. Heating and Cooling

• R32 refrigerant



NEW
2020

Technical focus

Top level COP 5,33 — 598 x 600 mm footprint — Reduced installation costs — Reduced installation time and minimised installation errors — Easy remote controller to set up — Reduced installation spaces — Electrical connections at the front — Easier installation and maintenance — Remote controller functions (cooling mode activation possible by software. This activation can only be done by service partner)



CZ-TAW1
Cloud connection. For user control and installer remote maintenance.

| | | | Single Phase (Power to indoor) | | | |
|--|-----------------------|-----------|--------------------------------|--------------------------|--------------------------|--------------------------|
| Kit | | | KIT-ADC03JE5C | KIT-ADC05JE5C | KIT-ADC07JE5C | KIT-ADC09JE5C-1 |
| Heating capacity / COP (A +7 °C, W 35 °C) | kW / COP | | 3,20/5,33 | 5,00/5,00 | 7,00/4,76 | 9,00/4,48 |
| Heating capacity / COP (A +7 °C, W 55 °C) | kW / COP | | 3,20/2,81 | 5,00/2,72 | 7,00/2,82 | 8,95/2,78 |
| Heating capacity / COP (A +2 °C, W 35 °C) | kW / COP | | 3,20/3,64 | 4,20/3,18 | 6,85/3,41 | 7,00/3,40 |
| Heating capacity / COP (A +2 °C, W 55 °C) | kW / COP | | 3,20/2,19 | 4,10/1,99 | 6,20/2,21 | 6,30/2,16 |
| Heating capacity / COP (A -7 °C, W 35 °C) | kW / COP | | 3,30/2,80 | 4,20/2,59 | 5,60/2,87 | 6,12/2,78 |
| Heating capacity / COP (A -7 °C, W 55 °C) | kW / COP | | 3,20/1,79 | 3,55/1,71 | 5,25/1,94 | 5,90/1,93 |
| Cooling capacity / EER (A 35 °C, W 7 °C) | kW / EER | | 3,20/3,52 | 4,50/3,00 | 6,70/3,03 | 8,20/2,72 |
| Cooling capacity / EER (A 35 °C, W 18 °C) | kW / EER | | 3,20/4,85 | 4,80/4,29 | 6,70/4,72 | 9,00/4,18 |
| Seasonal energy efficiency - Heating average climate (W35 °C / W55 °C) | ηs % | | 200/136 | 200/136 | 193/130 | 193/130 |
| SCOP | | | 5,07/3,47 | 5,07/3,47 | 4,90/3,32 | 4,90/3,32 |
| Energy class heating average climate (W35 °C / W55 °C) ¹⁾ | | | A+++ to D | A+++ / A++ | A+++ / A++ | A+++ / A++ |
| Seasonal energy efficiency - Heating warm climate (W35 °C / W55 °C) | ηs % | | 245/165 | 245/165 | 227/160 | 227/160 |
| SCOP | | | 6,20/4,20 | 6,20/4,20 | 5,75/4,07 | 5,75/4,07 |
| Energy class heating warm climate (W35 °C / W55 °C) ¹⁾ | | | A+++ to D | A+++ / A+++ | A+++ / A+++ | A+++ / A+++ |
| Seasonal energy efficiency - Heating cold climate (W35 °C / W55 °C) | ηs % | | 157/110 | 157/110 | 164/116 | 164/116 |
| SCOP | | | 4,00/2,83 | 4,00/2,83 | 4,18/2,98 | 4,18/2,98 |
| Energy class heating cold climate (W35 °C / W55 °C) ¹⁾ | | | A+++ to D | A++ / A+ | A++ / A+ | A++ / A+ |
| Indoor unit | | | WH-ADC0309J3E5C | WH-ADC0309J3E5C | WH-ADC0309J3E5C | WH-ADC0309J3E5C |
| Sound pressure | Heat / Cool | dB(A) | 28/28 | 28/28 | 28/28 | 28/28 |
| Dimension | HxWxD | mm | 1650x598x600 | 1650x598x600 | 1650x598x600 | 1650x598x600 |
| Net weight 1 zone / 2 zones | | kg | — | — | — | — |
| Water pipe connector | | Inch | R 1¼ | R 1¼ | R 1¼ | R 1¼ |
| A class pump | Number of speeds | | Variable Speed | Variable Speed | Variable Speed | Variable Speed |
| | Input power (Min/Max) | W | 30/120 | 30/120 | 30/120 | 30/120 |
| Heating water flow (ΔT=5 K, 35 °C) | | L/min | 9,20 | 14,30 | 20,10 | 25,80 |
| Capacity of integrated electric heater | | kW | 3,00 | 3,00 | 3,00 | 3,00 |
| Recommended fuse | | A | 16/16 | 16/16 | 25/16 | 25/16 |
| Recommended cable size, supply 1 / 2 | | mm² | 3x1,5/3x1,5 | 3x1,5/3x1,5 | 3x2,5/3x1,5 | 3x2,5/3x1,5 |
| Water volume | | L | 185 | 185 | 185 | 185 |
| Maximum water temperature | | °C | 65 | 65 | 65 | 65 |
| Material inside tank | | | Stainless steel | Stainless steel | Stainless steel | Stainless steel |
| Tapping profile according EN16147 | | | L | L | L | L |
| DHW tank ERP average climate efficiency rating ²⁾ | A+ to F | | A+ | A+ | A+ | A+ |
| DHW tank ERP warm climate efficiency rating ²⁾ | A+ to F | | A+ | A+ | A+ | A+ |
| DHW tank ERP cold climate efficiency rating ²⁾ | A+ to F | | A | A | A | A |
| DHW tank ERP average climate η / SCOP | ηwh % / SCOP | | 132/3,30 | 132/3,30 | 120/3,00 | 120/3,00 |
| DHW tank ERP warm climate η / SCOP | ηwh % / SCOP | | 155/3,88 | 155/3,88 | 140/3,50 | 140/3,50 |
| DHW tank ERP cold climate η / SCOP | ηwh % / SCOP | | 99/2,48 | 99/2,48 | 99/2,47 | 99/2,47 |
| Outdoor unit | | | WH-UD03JE5 | WH-UD05JE5 | WH-UD07JE5 | WH-UD09JE5-1 |
| Sound power part load ³⁾ | Heat | dB(A) | 55 | 55 | 59 | 59 |
| Sound power full load | Heat / Cool | dB(A) | 60/61 | 64/64 | 68/67 | 69/69 |
| Dimension / Net weight | HxWxD | mm / kg | 622x824x298/37 | 622x824x298/37 | 795x875x320/61 | 795x875x320/61 |
| Refrigerant (R32) / CO ₂ Eq. | | kg / T | 0,9/0,608 | 0,9/0,608 | 1,27/0,857 | 1,27/0,857 |
| Pipe diameter | Liquid / Gas | Inch (mm) | 1/4 (6,35) / 1/2 (12,70) | 1/4 (6,35) / 1/2 (12,70) | 1/4 (6,35) / 5/8 (15,88) | 1/4 (6,35) / 5/8 (15,88) |
| Pipe length range / Elevation difference (in/out) | | m / m | 3 - 25/20 | 3 - 25/20 | 3 - 50/30 | 3 - 50/30 |
| Pipe length for additional gas / Additional gas amount | | m / g/m | 10/20 | 10/20 | 10/25 | 10/25 |
| Operation range | Outdoor ambient | °C | -20 ~ +35 | -20 ~ +35 | -20 ~ +35 | -20 ~ +35 |
| Water outlet | Heat / Cool | °C | 20 ~ 60/5 ~ 20 | 20 ~ 60/5 ~ 20 | 20 ~ 60/5 ~ 20 | 20 ~ 60/5 ~ 20 |

Accessories (optional)

| | |
|----------------|--|
| CZ-TAW1 | Aquarea Smart Cloud for remote control and maintenance through wireless or wired LAN |
| CZ-NS4P | Additional functions PCB |

Accessories (optional)

| | |
|----------------------------|------------------------------|
| PAW-A2W-RTWIRED | Room thermostat |
| PAW-A2W-RTWIREDLESS | Wireless LCD room thermostat |

¹⁾ Scale from A+++ to D. ²⁾ Scale from A+ to F. ³⁾ Sound power in accordance to 8112013,81312013 and EN12102-1:2017 at +7 °C.

EER and COP calculation is based in accordance to EN14511. * Available in Autumn 2020.

This product is designed to comply with the European Water Quality Directive 98/83/EC amended by 2015/1787/EU. The lifespan of the product is not guaranteed in the case of the use of groundwater, such as spring water or well water, the use of tap water when salt or other impurities are contained, nor in areas of acidic water quality. Maintenance and warranty costs related to these cases are the customer's responsibility.



INTERNET CONTROL: Optional.

Aquarea High Performance Bi-bloc J Generation Single Phase. Heating and Cooling - SDC • R32 refrigerant



Technical focus

Super efficient in the 3,2 kW! — Very high energy savings A+++ — Simple installation & maintenance — Special software for low consumption homes with minimum output temperature: 20 °C — Works at temperatures as low as -20 °C — Automatic Air purge valve — Display of the compressor frequency



CZ-TAW1
Cloud connection.
For user control
and installer
remote
maintenance.

| | | | Single Phase (Power to indoor) | | | |
|--|-----------------------|-----------|--------------------------------|--------------------------|--------------------------|--------------------------|
| Kit | | | KIT-WC03J3E5 | KIT-WC05J3E5 | KIT-WC07J3E5 | KIT-WC09J3E5 |
| Heating capacity / COP [A +7 °C, W 35 °C] | kW / COP | | 3,20/5,33 | 5,00/5,00 | 7,00/4,76 | 9,00/4,48 |
| Heating capacity / COP [A +7 °C, W 55 °C] | kW / COP | | 3,20/2,81 | 5,00/2,72 | 7,00/2,82 | 8,95/2,78 |
| Heating capacity / COP [A +2 °C, W 35 °C] | kW / COP | | 3,20/3,64 | 4,20/3,18 | 6,85/3,41 | 7,00/3,40 |
| Heating capacity / COP [A +2 °C, W 55 °C] | kW / COP | | 3,20/2,19 | 4,10/1,99 | 6,20/2,21 | 6,30/2,16 |
| Heating capacity / COP [A -7 °C, W 35 °C] | kW / COP | | 3,30/2,80 | 4,20/2,59 | 5,60/2,87 | 6,12/2,78 |
| Heating capacity / COP [A -7 °C, W 55 °C] | kW / COP | | 3,20/1,79 | 3,55/1,71 | 5,25/1,94 | 5,90/1,93 |
| Cooling capacity / EER [A 35 °C, W 7 °C] | kW / EER | | 3,20/3,52 | 4,50/3,00 | 6,70/3,03 | 8,20/2,72 |
| Cooling capacity / EER [A 35 °C, W 18 °C] | kW / EER | | 3,20/4,85 | 4,80/4,29 | 6,70/4,72 | 9,00/4,18 |
| Seasonal energy efficiency - Heating average climate [W35 °C / W55 °C] | ηs % | | 200/136 | 200/136 | 193/130 | 193/130 |
| | SCOP | | 5,07/3,47 | 5,07/3,47 | 4,90/3,32 | 4,90/3,32 |
| Energy class heating average climate [W35 °C / W55 °C] | A+++ to D | | A+++/A++ | A+++/A++ | A+++/A++ | A+++/A++ |
| Seasonal energy efficiency - Heating warm climate [W35 °C / W55 °C] | ηs % | | 245/165 | 245/165 | 227/160 | 227/160 |
| | SCOP | | 6,20/4,20 | 6,20/4,20 | 5,75/4,07 | 5,75/4,07 |
| Energy class heating warm climate [W35 °C / W55 °C] | A+++ to D | | A+++/A+++ | A+++/A+++ | A+++/A+++ | A+++/A+++ |
| Seasonal energy efficiency - Heating cold climate [W35 °C / W55 °C] | ηs % | | 157/110 | 157/110 | 164/116 | 164/116 |
| | SCOP | | 4,00/2,83 | 4,00/2,83 | 4,18/2,98 | 4,18/2,98 |
| Energy class heating cold climate [W35 °C / W55 °C] | A+++ to D | | A++/A+ | A++/A+ | A++/A+ | A++/A+ |
| Indoor unit | | | WH-SDC0305J3E5 | WH-SDC0305J3E5 | WH-SDC0709J3E5 | WH-SDC0709J3E5 |
| Sound pressure | Heat / Cool | dB(A) | 28/28 | 28/28 | 30/30 | 30/31 |
| Dimension | H x W x D | mm | 892 x 500 x 340 | 892 x 500 x 340 | 892 x 500 x 340 | 892 x 500 x 340 |
| Net weight | | kg | 42 | 42 | 42 | 42 |
| Water pipe connector | | Inch | R 1¼ | R 1¼ | R 1¼ | R 1¼ |
| A class pump | Number of speeds | | Variable Speed | Variable Speed | Variable Speed | Variable Speed |
| | Input power (Min/Max) | W | 30/100 | 33/106 | 34/114 | 40/120 |
| Heating water flow (ΔT=5 K, 35 °C) | | L/min | 9,2 | 14,3 | 20,1 | 25,8 |
| Capacity of integrated electric heater | | kW | 3 | 3 | 3 | 3 |
| Recommended fuse | | A | 15/30 | 15/30 | 15/30 | 15/30 |
| Recommended cable size, supply 1 / 2 | | mm² | 3 x 1,5/3 x 1,5 | 3 x 1,5/3 x 1,5 | 3 x 2,5/3 x 1,5 | 3 x 2,5/3 x 1,5 |
| Outdoor unit | | | WH-UD03J3E5 | WH-UD05J3E5 | WH-UD07J3E5 | WH-UD09J3E5-1 |
| Sound power part load ¹⁾ | Heat | dB(A) | 55 | 55 | 59 | 59 |
| Sound power full load | Heat / Cool | dB(A) | 60/61 | 64/64 | 68/67 | 69/69 |
| Dimension | H x W x D | mm | 622 x 824 x 298 | 622 x 824 x 298 | 795 x 875 x 320 | 795 x 875 x 320 |
| Net weight | | kg | 37 | 37 | 61 | 61 |
| Refrigerant (R32) / CO ₂ Eq. | | kg / T | 0,9/0,608 | 0,9/0,608 | 1,27/0,857 | 1,27/0,857 |
| Pipe diameter | Liquid / Gas | Inch (mm) | 1/4 (6,35) / 1/2 (12,70) | 1/4 (6,35) / 1/2 (12,70) | 1/4 (6,35) / 5/8 (15,88) | 1/4 (6,35) / 5/8 (15,88) |
| Pipe length range | | m | 3 ~ 25 | 3 ~ 25 | 3 ~ 50 | 3 ~ 50 |
| Elevation difference (in/out) | | m | 20 | 20 | 30 | 30 |
| Pipe length for additional gas | | m | 10 | 10 | 10 | 10 |
| Additional gas amount | | g/m | 20 | 20 | 25 | 25 |
| Operation range | Outdoor ambient | °C | -20 ~ +35 | -20 ~ +35 | -20 ~ +35 | -20 ~ +35 |
| Water outlet | Heat / Cool | °C | 20 ~ 60/5 ~ 20 | 20 ~ 60/5 ~ 20 | 20 ~ 60/5 ~ 20 | 20 ~ 60/5 ~ 20 |

Accessories (optional)

| | |
|------------------------|--|
| PAW-TD20C1E5 | Tank 200L - Stainless steel |
| PAW-TD30C1E5 | Tank 300L - Stainless steel |
| PAW-TA20C1E5STD | Tank 200L - Enamelled |
| PAW-TA30C1E5STD | Tank 300L - Enamelled |
| PAW-3WYVLV-HW | 3 way valve for DHW Tanks |
| CZ-NV1 | 3 way valve kit for inside of hydrokit |

Accessories (optional)

| | |
|---------------------------|--|
| CZ-NS4P | Additional functions PCB |
| PAW-BTANK50L-2 | Buffer tank 50L |
| CZ-TAW1 | Aquarea Smart Cloud for remote control and maintenance through wireless or wired LAN |
| PAW-A2W-RTWIRED | Room thermostat |
| PAW-A2W-RTWIRELESS | Wireless LCD room thermostat |

1) Sound power in accordance to 8112013,81312013 and EN12102-1:2017 at +7 °C. EER and COP calculation is based in accordance to EN14511.



INTERNET CONTROL: Optional. GOOD DESIGN AWARD 2017: Indoor units All in One and Bi-bloc H Generation awarded with the prestigious Good Design Award 2017.

New Aquarea High Performance Mono-bloc J Generation Single Phase Heating and Cooling - MDC

- R32 refrigerant

NEW 2020



Technical focus

Optional Smartphone control — Maximum hydraulic module output temperature: 60 °C — High heating and cooling capacities, even at low outdoor temperatures, temperature range 5 ~ 20 °C — Works at temperatures as low as -20 °C — Operation in cooling mode at temperatures as low as 10 °C — Built-in magnet filter for easy installation

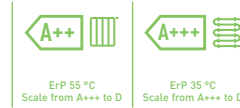

CZ-TAW1
Cloud connection.
For user control
and installer
remote
maintenance.

Single Phase Heating and Cooling

| Outdoor unit | | WH-MDC05J3E5 | WH-MDC07J3E5 | WH-MDC09J3E5 |
|--|-----------------------|----------------------|----------------------|----------------------|
| Heating capacity / COP (A +7 °C, W 35 °C) | kW / COP | 5,00/5,08 | 7,00/4,76 | 9,00/4,48 |
| Heating capacity / COP (A +7 °C, W 55 °C) | kW / COP | 5,00/3,01 | 7,00/2,82 | 8,95/2,78 |
| Heating capacity / COP (A +2 °C, W 35 °C) | kW / COP | 5,00/3,57 | 7,00/3,40 | 7,45/3,13 |
| Heating capacity / COP (A +2 °C, W 55 °C) | kW / COP | 5,00/2,27 | 6,30/2,16 | 7,00/2,12 |
| Heating capacity / COP (A -7 °C, W 35 °C) | kW / COP | 5,00/2,78 | 6,80/2,81 | 7,50/2,63 |
| Heating capacity / COP (A -7 °C, W 55 °C) | kW / COP | 5,00/1,85 | 6,30/1,86 | 7,00/1,80 |
| Cooling capacity / EER (A 35 °C, W 7 °C) | kW / EER | 5,00/3,31 | 7,00/3,06 | 9,00/2,71 |
| Cooling capacity / EER (A 35 °C, W 18 °C) | kW / EER | 5,00/5,05 | 7,00/4,73 | 9,00/4,25 |
| Seasonal energy efficiency - Heating average climate (W35 °C / W55 °C) | ηs % SCOP | 202/142 5,12/3,63 | 193/130 4,90/3,32 | 193/130 4,90/3,32 |
| Energy class heating average climate (W35 °C / W55 °C) | A+++ to D | A+++/A++ | A+++/A++ | A+++/A++ |
| Seasonal energy efficiency - Heating warm climate (W35 °C / W55 °C) | ηs % SCOP | 237/165 6,00/4,20 | 227/160 5,75/4,07 | 227/160 5,75/4,07 |
| Energy class heating warm climate (W35 °C / W55 °C) | A+++ to D | A+++/A+++ | A+++/A+++ | A+++/A+++ |
| Seasonal energy efficiency - Heating cold climate (W35 °C / W55 °C) | ηs % SCOP | 160/115 4,08/2,95 | 164/116 4,18/2,98 | 164/116 4,18/2,98 |
| Energy class heating cold climate (W35 °C / W55 °C) | A+++ to D | A++/A+ | A++/A+ | A++/A+ |
| Sound power part load ¹⁾ Heat | dB(A) | 59 | 59 | 59 |
| Sound power full load Heat / Cool | dB(A) | 64/65 | 68/67 | 69/68 |
| Dimension | HxWxD | mm 865 x 1283 x 320 | 865 x 1283 x 320 | 865 x 1283 x 320 |
| Net weight | kg | 99 | 104 | 104 |
| Refrigerant (R32) / CO ₂ Eq. ²⁾ | kg / T | 1,3/0,878 | 1,3/0,878 | 1,3/0,878 |
| Water pipe connector | Inch | R 1½ | R 1½ | R 1½ |
| Pump | Number of speeds | Variable Speed | Variable Speed | Variable Speed |
| | Input power (Min/Max) | W 34/96 | 36/100 | 39/108 |
| Heating water flow (ΔT=5 K, 35 °C) | L/min | 14,3 | 20,1 | 25,8 |
| Capacity of integrated electric heater | kW | 3 | 3 | 3 |
| Input Power | Heat | kW 0,985 | 1,47 | 2,01 |
| | Cool | kW 1,51 | 2,29 | 3,32 |
| Running and Starting current | Heat | A 4,7 | 7,0 | 9,3 |
| | Cool | A 7,0 | 10,5 | 14,7 |
| Current 1 | A | 12 | 17 | 17 |
| Current 2 | A | 13 | 13 | 13 |
| Recommended fuse | A | 30/15 | 30/15 | 30/16 |
| Recommended cable size, supply 1 / 2 | mm ² | 3 x 1,5/3 x 1,5 | 3 x 2,5/3 x 1,5 | 3 x 2,5/3 x 1,5 |
| Operation range (outdoor temperature) | Heat | °C -20 ~ -35 | -20 ~ -35 | -20 ~ -35 |
| | Cool | °C 10 ~ 43 | 10 ~ 43 | 10 ~ 43 |
| Water outlet | Heat | °C 20 ~ 60 | 20 ~ 60 | 20 ~ 60 |
| | Cool | °C 5 ~ 20 | 5 ~ 20 | 5 ~ 20 |

Accessories (optional)

| | |
|------------------------|---|
| PAW-TD20C1E5 | Tank 200L - Stainless steel |
| PAW-TD30C1E5 | Tank 300L - Stainless steel |
| PAW-TA20C1E5STD | Tank 200L - Enamelled |
| PAW-TA30C1E5STD | Tank 300L - Enamelled |
| PAW-TD20B8E3-1 | Combo Tank 185L + 80L - Enamelled |
| PAW-TD23B6E5 | Combo Tank 230L + 60L - Stainless steel |

Accessories (optional)

| | |
|----------------------------|--|
| PAW-3WYVLV-HW | 3 way valve for DHW Tanks |
| PAW-BTANK50L-2 | Buffer tank 50L |
| CZ-TAW1 | Aquarea Smart Cloud for remote control and maintenance through wireless or wired LAN |
| PAW-A2W-RTWIRED | Room thermostat |
| PAW-A2W-RTWIREDLESS | Wireless LCD room thermostat |

¹⁾ Sound power in accordance to 8112013, 81312013 and EN12102-1:2017 at +7 °C. ²⁾ WH-MDC models are hermetically sealed. EER and COP calculation is based in accordance to EN14511. * Available in May 2020.



INTERNET CONTROL: Optional.

Aquarea High Performance All in One H Generation Single Phase. Heating and Cooling 1 or 2 zones

- R410A refrigerant



Technical focus

Reduced installation costs — Piping at the bottom of the All in One (easy to install) — Reduced installation time and minimised installation errors — Easy remote controller to set up — Reduced installation spaces — Electrical connections at the front — Easier installation and maintenance — Remote controller functions (cooling mode activation possible by software. This activation can only be done by service partner)



CZ-TAW1
Cloud connection.
For user control and installer remote maintenance.

| | | Single Phase (Power to indoor) | | | |
|--|-----------------------|--------------------------------|--------------------------|--------------------------|--------------------------|
| | | KIT-ADC03HE5 | KIT-ADC05HE5 | KIT-ADC07HE5 | KIT-ADC09HE5 |
| Kit 1 zone (for 2 zone add B at the end) | | | | | |
| Heating capacity / COP (A +7 °C, W 35 °C) | kW / COP | 3,20/5,00 | 5,00/4,63 | 7,00/4,46 | 9,00/4,13 |
| Heating capacity / COP (A +7 °C, W 55 °C) | kW / COP | 3,20/2,67 | 5,00/2,65 | 6,80/2,63 | 8,90/2,41 |
| Heating capacity / COP (A +2 °C, W 35 °C) | kW / COP | 3,20/3,56 | 4,20/3,11 | 6,55/3,34 | 6,70/3,13 |
| Heating capacity / COP (A +2 °C, W 55 °C) | kW / COP | 3,20/2,15 | 4,10/1,98 | 6,00/1,99 | 6,00/1,99 |
| Heating capacity / COP (A -7 °C, W 35 °C) | kW / COP | 3,20/2,69 | 4,20/2,59 | 5,15/2,68 | 5,90/2,52 |
| Heating capacity / COP (A -7 °C, W 55 °C) | kW / COP | 3,20/1,72 | 3,55/1,71 | 4,80/1,89 | 5,80/1,88 |
| Cooling capacity / EER (A 35 °C, W 7 °C) | kW / EER | 3,20/3,08 | 4,50/2,69 | 6,00/2,63 | 7,00/2,43 |
| Cooling capacity / EER (A 35 °C, W 18 °C) | kW / EER | 3,30/3,75 | 5,00/3,76 | 6,00/3,57 | 7,00/3,26 |
| Seasonal energy efficiency - Heating average climate (W35 °C / W55 °C) | ηs % | 195/130 | 195/130 | 190/130 | 190/130 |
| | SCOP | 4,95/3,33 | 4,95/3,33 | 4,83/3,33 | 4,83/3,33 |
| Energy class heating average climate (W35 °C / W55 °C) ¹⁾ | A+++ to D | A+++ / A++ | A+++ / A++ | A+++ / A++ | A+++ / A++ |
| Seasonal energy efficiency - Heating warm climate (W35 °C / W55 °C) | ηs % | 244/163 | 244/163 | 225/160 | 225/160 |
| | SCOP | 6,18/4,15 | 6,18/4,15 | 5,70/4,08 | 5,70/4,08 |
| Energy class heating warm climate (W35 °C / W55 °C) ¹⁾ | A+++ to D | A+++ / A+++ | A+++ / A+++ | A+++ / A+++ | A+++ / A+++ |
| Seasonal energy efficiency - Heating cold climate (W35 °C / W55 °C) | ηs % | 150/103 | 150/103 | 160/115 | 160/115 |
| | SCOP | 3,83/2,65 | 3,83/2,65 | 4,08/2,95 | 4,08/2,95 |
| Energy class heating cold climate (W35 °C / W55 °C) ¹⁾ | A+++ to D | A++ / A+ | A++ / A+ | A++ / A+ | A++ / A+ |
| Indoor unit 1 zone hydrokit | | WH-ADC0309H3E5 | WH-ADC0309H3E5 | WH-ADC0309H3E5 | WH-ADC0309H3E5 |
| Indoor unit 2 zones built-in hydrokit | | WH-ADC0309H3E5B | WH-ADC0309H3E5B | WH-ADC0309H3E5B | WH-ADC0309H3E5B |
| Sound pressure | Heat / Cool | 28/28 | 28/28 | 28/28 | 28/28 |
| Dimension / Net weight | HxWxD | 1800x598x717/124 | 1800x598x717/124 | 1800x598x717/124 | 1800x598x717/124 |
| Water pipe connector | | R 1½ | R 1½ | R 1½ | R 1½ |
| A class pump | Number of speeds | Variable Speed | Variable Speed | Variable Speed | Variable Speed |
| | Input power (Min/Max) | 30/120 | 30/120 | 30/120 | 30/120 |
| Heating water flow (ΔT=5 K, 35 °C) | L/min | 9,2 | 14,3 | 20,1 | 25,8 |
| Capacity of integrated electric heater | kW | 3 | 3 | 3 | 3 |
| Recommended fuse | A | 15/15 | 15/15 | 30/15 | 30/15 |
| Recommended cable size, supply 1 / 2 | mm² | 3x1,5/3x1,5 | 3x1,5/3x1,5 | 3x2,5/3x1,5 | 3x2,5/3x1,5 |
| Water volume | L | 185 | 185 | 185 | 185 |
| Maximum water temperature | °C | 65 | 65 | 65 | 65 |
| Material inside tank | | Stainless steel | Stainless steel | Stainless steel | Stainless steel |
| Tapping profile according EN16147 | | L | L | L | L |
| DHW tank ERP average climate efficiency rating ²⁾ | A+ to F | A+ | A+ | A | A |
| DHW tank ERP warm climate efficiency rating ²⁾ | A+ to F | A+ | A+ | A+ | A+ |
| DHW tank ERP cold climate efficiency rating ²⁾ | A+ to F | A | A | A | A |
| DHW tank ERP average climate η / SCOP | ηwh % / SCOP | 120/3,00 | 120/3,00 | 113/2,83 | 113/2,83 |
| DHW tank ERP warm climate η / SCOP | ηwh % / SCOP | 147/3,68 | 147/3,68 | 132/3,30 | 132/3,30 |
| DHW tank ERP cold climate η / SCOP | ηwh % / SCOP | 94/2,35 | 94/2,15 | 86/2,15 | 86/1,88 |
| Outdoor unit | | WH-UD03HE5-1 | WH-UD05HE5-1 | WH-UD07HE5-1 | WH-UD09HE5-1 |
| Sound power part load ³⁾ | Heat | 55 | 55 | 59 | 59 |
| Sound power full load | Heat / Cool | 64/65 | 65/66 | 68/66 | 69/68 |
| Dimension / Net weight | HxWxD | 622x824x298/39 | 622x824x298/39 | 795x900x320/66 | 795x900x320/66 |
| Refrigerant (R410A) / CO ₂ Eq. | kg / T | 1,20/2,506 | 1,20/2,506 | 1,45/3,028 | 1,45/3,028 |
| Pipe diameter | Liquid / Gas | 1/4 (6,35) / 1/2 (12,70) | 1/4 (6,35) / 1/2 (12,70) | 1/4 (6,35) / 5/8 (15,88) | 1/4 (6,35) / 5/8 (15,88) |
| Pipe length range / Elevation difference (in/out) | m / m | 3-15/5 | 3-15/5 | 3-40/30 | 3-40/30 |
| Pipe length for additional gas / Additional gas amount | m / g/m | 10/20 | 10/20 | 10/30 | 10/30 |
| Operation range | Outdoor ambient | -20 ~ +35 | -20 ~ +35 | -20 ~ +35 | -20 ~ +35 |
| Water outlet | Heat / Cool | 20 ~ 55/5 ~ 20 | 20 ~ 55/5 ~ 20 | 20 ~ 55/5 ~ 20 | 20 ~ 55/5 ~ 20 |

Accessories (optional)

| | |
|-------------------------|--|
| PAW-ADC-PREKIT-H | Piping pre installation kit for H Generation |
| PAW-ADC-CV150 | Decorative magnetic side cover |
| CZ-TAW1 | Aquarea Smart Cloud for remote control and maintenance through wireless or wired LAN |

Accessories (optional)

| | |
|----------------------------|------------------------------|
| CZ-NS4P | Additional functions PCB |
| PAW-A2W-RTWIRED | Room thermostat |
| PAW-A2W-RTWIREDLESS | Wireless LCD room thermostat |

1) Scale from A+++ to D. 2) Scale from A+ to F. 3) Sound power in accordance to 8112013,81312013 and EN12102-1:2017 at +7 °C.

EER and COP calculation is based in accordance to EN14511.

This product is designed to comply with the European Water Quality Directive 98/83/EC amended by 2015/1787/EU. The lifespan of the product is not guaranteed in the case of the use of groundwater, such as spring water or well water, the use of tap water when salt or other impurities are contained, nor in areas of acidic water quality. Maintenance and warranty costs related to these cases are the customer's responsibility.



INTERNET CONTROL: Optional. GOOD DESIGN AWARD 2017: Indoor units All in One and Bi-bloc H Generation awarded with the prestigious Good Design Award 2017.

Aquarea High Performance All in One H Generation Single Phase / Three Phase. Heating and Cooling

- R410A refrigerant



Technical focus

Reduced installation costs — Piping at the bottom of the All in One (easy to install) — Reduced installation time and minimised installation errors — Easy remote controller to set up — Reduced installation spaces — Electrical connections at the front — Easier installation and maintenance — Remote controller functions (cooling mode activation possible by software. This activation can only be done by service partner)



CZ-TAW1
Cloud connection. For user control and installer remote maintenance.

| Kit | Single Phase (Power to indoor) | | | | | Three Phase (Power to indoor) | | | | | |
|--|--------------------------------|-----------------------|-----------------------|-----------------------|-----------------------|-------------------------------|--|-----------------|--|-----------------|--|
| | | KIT-ADC12HE5 | KIT-ADC16HE5 | KIT-ADC09HE8 | KIT-ADC12HE8 | KIT-ADC16HE8 | | | | | |
| Heating capacity / COP (A +7 °C, W 35 °C) | kW / COP | 12,00/4,74 | 16,00/4,28 | 9,00/4,84 | 12,00/4,74 | 16,00/4,28 | | | | | |
| Heating capacity / COP (A +7 °C, W 55 °C) | kW / COP | 12,00/2,88 | 14,50/2,68 | 9,00/2,94 | 12,00/2,88 | 14,50/2,68 | | | | | |
| Heating capacity / COP (A +2 °C, W 35 °C) | kW / COP | 11,40/3,44 | 13,00/3,28 | 9,00/3,59 | 11,40/3,44 | 13,00/3,28 | | | | | |
| Heating capacity / COP (A +2 °C, W 55 °C) | kW / COP | 9,10/2,20 | 9,80/2,17 | 8,80/2,23 | 9,10/2,20 | 9,80/2,17 | | | | | |
| Heating capacity / COP (A -7 °C, W 35 °C) | kW / COP | 10,00/2,73 | 11,40/2,57 | 9,00/2,85 | 10,00/2,73 | 11,40/2,57 | | | | | |
| Heating capacity / COP (A -7 °C, W 55 °C) | kW / COP | 8,20/1,92 | 9,00/1,82 | 7,90/2,05 | 8,20/1,92 | 9,00/1,82 | | | | | |
| Cooling capacity / EER (A 35 °C, W 7 °C) | kW / EER | 10,00/2,81 | 12,20/2,56 | 7,00/3,17 | 10,00/2,85 | 12,20/2,56 | | | | | |
| Cooling capacity / EER (A 35 °C, W 18 °C) | kW / EER | 10,00/4,17 | 12,20/4,12 | 7,00/4,61 | 10,00/4,17 | 12,20/4,12 | | | | | |
| Seasonal energy efficiency - Heating average climate (W35 °C / W55 °C) | ηs % | 190/134 | 190/130 | 190/133 | 190/134 | 190/130 | | | | | |
| SCOP | | 4,83/3,43 | 4,83/3,33 | 4,83/3,40 | 4,83/3,43 | 4,83/3,33 | | | | | |
| Energy class heating average climate (W35 °C / W55 °C) ¹⁾ | | A+++ to D | A+++/A++ | A+++/A++ | A+++/A++ | A+++/A++ | | | | | |
| Seasonal energy efficiency - Heating warm climate (W35 °C / W55 °C) | ηs % | 245/159 | 245/169 | 245/159 | 245/159 | 245/169 | | | | | |
| SCOP | | 6,20/4,05 | 6,20/4,30 | 6,20/4,05 | 6,20/4,05 | 6,20/4,30 | | | | | |
| Energy class heating warm climate (W35 °C / W55 °C) ¹⁾ | | A+++ to D | A+++/A+++ | A+++/A+++ | A+++/A+++ | A+++/A+++ | | | | | |
| Seasonal energy efficiency - Heating cold climate (W35 °C / W55 °C) | ηs % | 168/121 | 168/121 | 168/121 | 168/121 | 168/121 | | | | | |
| SCOP | | 4,28/3,10 | 4,28/3,10 | 4,28/3,10 | 4,28/3,10 | 4,28/3,10 | | | | | |
| Energy class heating cold climate (W35 °C / W55 °C) ¹⁾ | | A+++ to D | A++/A+ | A++/A+ | A++/A+ | A++/A+ | | | | | |
| Indoor unit | | WH-ADC1216H6E5 | WH-ADC1216H6E5 | WH-ADC0916H9E8 | WH-ADC0916H9E8 | WH-ADC0916H9E8 | | | | | |
| Sound pressure | Heat / Cool | dB(A) | | dB(A) | | dB(A) | | dB(A) | | dB(A) | |
| Dimension / Net weight | HxWxD | mm / kg | | mm / kg | | mm / kg | | mm / kg | | mm / kg | |
| Water pipe connector | | Inch | | Inch | | Inch | | Inch | | Inch | |
| A class pump | Number of speeds | Variable Speed | | Variable Speed | | Variable Speed | | Variable Speed | | Variable Speed | |
| | Input power (Min/Max) | W | | W | | W | | W | | W | |
| Heating water flow (ΔT=5 K, 35 °C) | | L/min | | L/min | | L/min | | L/min | | L/min | |
| Capacity of integrated electric heater | | kW | | kW | | kW | | kW | | kW | |
| Recommended fuse | | A | | A | | A | | A | | A | |
| Recommended cable size, supply 1 / 2 | | mm ² | | mm ² | | mm ² | | mm ² | | mm ² | |
| Water volume | | L | | L | | L | | L | | L | |
| Maximum water temperature | | °C | | °C | | °C | | °C | | °C | |
| Material inside tank | | Stainless steel | | Stainless steel | | Stainless steel | | Stainless steel | | Stainless steel | |
| Tapping profile according EN16147 | | L | | L | | L | | L | | L | |
| DHW tank ERP average climate efficiency rating ²⁾ | | A | | A | | A | | A | | A | |
| DHW tank ERP warm climate efficiency rating ²⁾ | | A | | A | | A | | A | | A | |
| DHW tank ERP cold climate efficiency rating ²⁾ | | A | | B | | A | | A | | B | |
| DHW tank ERP average climate η / SCOP | | ηwh % / SCOP | | ηwh % / SCOP | | ηwh % / SCOP | | ηwh % / SCOP | | ηwh % / SCOP | |
| DHW tank ERP warm climate η / SCOP | | 110/2,75 | | 107/2,68 | | 110/2,75 | | 110/2,75 | | 107/2,68 | |
| DHW tank ERP cold climate η / SCOP | | 75/1,80 | | 72/1,88 | | 75/1,88 | | 75/1,80 | | 72/1,88 | |
| Outdoor unit | | WH-UD12HE5 | WH-UD16HE5 | WH-UD09HE8 | WH-UD12HE8 | WH-UD16HE8 | | | | | |
| Sound power part load ³⁾ | Heat | dB(A) | | dB(A) | | dB(A) | | dB(A) | | dB(A) | |
| Sound power full load | Heat / Cool | dB(A) | | dB(A) | | dB(A) | | dB(A) | | dB(A) | |
| Dimension / Net weight | HxWxD | mm / kg | | mm / kg | | mm / kg | | mm / kg | | mm / kg | |
| Refrigerant (R410A) / CO ₂ Eq. | | kg / T | | kg / T | | kg / T | | kg / T | | kg / T | |
| Pipe diameter | Liquid / Gas | Inch (mm) | | Inch (mm) | | Inch (mm) | | Inch (mm) | | Inch (mm) | |
| Pipe length range / Elevation difference (in/out) | | m / m | | m / m | | m / m | | m / m | | m / m | |
| Pipe length for additional gas / Additional gas amount | | m / g/m | | m / g/m | | m / g/m | | m / g/m | | m / g/m | |
| Operation range | Outdoor ambient | °C | | °C | | °C | | °C | | °C | |
| Water outlet | Heat / Cool | °C | | °C | | °C | | °C | | °C | |

Accessories (optional)

| | |
|-------------------------|--|
| PAW-ADC-PREKIT-H | Piping pre installation kit for H Generation |
| PAW-ADC-CV150 | Decorative magnetic side cover |
| CZ-TAW1 | Aquarea Smart Cloud for remote control and maintenance through wireless or wired LAN |

Accessories (optional)

| | |
|---------------------------|------------------------------|
| CZ-NS4P | Additional functions PCB |
| PAW-A2W-RTWIRED | Room thermostat |
| PAW-A2W-RTWIRELESS | Wireless LCD room thermostat |

¹⁾ Scale from A+++ to D. ²⁾ Scale from A+ to F. ³⁾ Sound power in accordance to 8112013,81312013 and EN12102-1:2017 at +7 °C.

EER and COP calculation is based in accordance to EN14511.

This product is designed to comply with the European Water Quality Directive 98/83/EC amended by 2015/1787/EU. The lifespan of the product is not guaranteed in the case of the use of groundwater, such as spring water or well water, the use of tap water when salt or other impurities are contained, nor in areas of acidic water quality. Maintenance and warranty costs related to these cases are the customer's responsibility.



INTERNET CONTROL: Optional. GOOD DESIGN AWARD 2017: Indoor units All in One and Bi-bloc H Generation awarded with the prestigious Good Design Award 2017.

Aquarea T-CAP All in One H Generation Single Phase / Three Phase. Heating and Cooling

- R410A refrigerant



Technical focus

Works at temperatures as low as -28 °C — Constant capacity up to -20 °C — Reduced installation costs — Reduced installation time and minimised installation errors — Easy remote controller to set up — Electrical connections at the front — Easier installation and maintenance — Remote controller functions (cooling mode activation possible by software. This activation can only be done by service partner)



CZ-TAW1
Cloud connection.
For user control
and installer
remote
maintenance.

| Kit | Single Phase (Power to indoor) | | | Three Phase (Power to indoor) | | |
|--|--------------------------------|-----------------------|-----------------------|-------------------------------|-----------------------|-----------------------|
| | KIT-AXC09HE5 | KIT-AXC12HE5 | KIT-AXC09HE8 | KIT-AXC12HE8 | KIT-AXC16HE8 | |
| Heating capacity / COP [A +7 °C, W 35 °C] | kW / COP | 9,00/4,84 | 12,00/4,74 | 9,00/4,84 | 12,00/4,74 | 16,00/4,28 |
| Heating capacity / COP [A +7 °C, W 55 °C] | kW / COP | 9,00/2,94 | 12,00/2,88 | 9,00/2,94 | 12,00/2,88 | 16,00/2,71 |
| Heating capacity / COP [A +2 °C, W 35 °C] | kW / COP | 9,00/3,59 | 12,00/3,44 | 9,00/3,59 | 12,00/3,44 | 16,00/3,10 |
| Heating capacity / COP [A +2 °C, W 55 °C] | kW / COP | 9,00/2,21 | 12,00/2,19 | 9,00/2,21 | 12,00/2,19 | 16,00/2,13 |
| Heating capacity / COP [A -7 °C, W 35 °C] | kW / COP | 9,00/2,85 | 12,00/2,72 | 9,00/2,85 | 12,00/2,72 | 16,00/2,49 |
| Heating capacity / COP [A -7 °C, W 55 °C] | kW / COP | 9,00/2,02 | 12,00/1,92 | 9,00/2,02 | 12,00/1,92 | 16,00/1,86 |
| Cooling capacity / EER [A 35 °C, W 7 °C] | kW / EER | 7,00/3,17 | 10,00/2,81 | 7,00/3,17 | 10,00/2,81 | 12,20/2,57 |
| Cooling capacity / EER [A 35 °C, W 18 °C] | kW / EER | 7,00/5,19 | 10,00/5,13 | 7,00/5,19 | 10,00/5,13 | 12,20/3,49 |
| Seasonal energy efficiency - Heating average climate (W35 °C / W55 °C) | ηs % | 181/130 | 170/130 | 181/130 | 170/130 | 160/125 |
| Energy class heating average climate (W35 °C / W55 °C) ¹⁾ | SCOP | 4,60/3,33 | 4,33/3,33 | 4,60/3,33 | 4,33/3,33 | 4,08/3,20 |
| Seasonal energy efficiency - Heating warm climate (W35 °C / W55 °C) | ηs % | 235/158 | 231/158 | 235/158 | 231/158 | 231/159 |
| Energy class heating warm climate (W35 °C / W55 °C) ¹⁾ | SCOP | 5,95/4,03 | 5,85/4,03 | 5,95/4,03 | 5,85/4,03 | 5,85/4,05 |
| Seasonal energy efficiency - Heating cold climate (W35 °C / W55 °C) | ηs % | 160/125 | 160/125 | 160/125 | 160/125 | 150/125 |
| Energy class heating cold climate (W35 °C / W55 °C) ¹⁾ | SCOP | 4,08/3,20 | 4,08/3,20 | 4,08/3,20 | 4,08/3,20 | 3,83/3,20 |
| Indoor unit | | WH-ADC1216H6E5 | WH-ADC1216H6E5 | WH-ADC0916H9E8 | WH-ADC0916H9E8 | WH-ADC0916H9E8 |
| Sound pressure | Heat / Cool | 33/33 | 33/33 | 33/33 | 33/33 | 33/33 |
| Dimension / Net weight | HxWxD | 1800x598x717/124 | 1800x598x717/124 | 1800x598x717/126 | 1800x598x717/126 | 1800x598x717/126 |
| Water pipe connector | | R 1½ | R 1½ | R 1½ | R 1½ | R 1½ |
| A class pump | Number of speeds | Variable Speed | Variable Speed | Variable Speed | Variable Speed | Variable Speed |
| | Input power (Min/Max) | W | 36/152 | 36/152 | 36/152 | 36/152 |
| Heating water flow [ΔT=5 K, 35 °C] | | L/min | 25,8 | 34,4 | 25,8 | 34,4 |
| Capacity of integrated electric heater | | kW | 6 | 6 | 9 | 9 |
| Recommended fuse | | A | 30/30 | 30/30 | 16/16 | 16/16 |
| Recommended cable size, supply 1 / 2 | | mm² | 3x4,0/3x4,0 | 3x4,0/3x4,0 | 5x1,5/5x1,5 | 5x1,5/5x1,5 |
| Water volume | | L | 185 | 185 | 185 | 185 |
| Maximum water temperature | | °C | 65 | 65 | 65 | 65 |
| Material inside tank | | | Stainless steel | Stainless steel | Stainless steel | Stainless steel |
| Tapping profile according EN16147 | | L | L | L | L | L |
| DHW tank ERP average climate efficiency rating ²⁾ | A+ to F | A | A | A | A | A |
| DHW tank ERP warm climate efficiency rating ²⁾ | A+ to F | A | A | A | A | A |
| DHW tank ERP cold climate efficiency rating ²⁾ | A+ to F | A | A | A | A | B |
| DHW tank ERP average climate η / SCOP | ηwh % / SCOP | 95/2,38 | 95/2,38 | 95/2,38 | 95/2,38 | 91/2,28 |
| DHW tank ERP warm climate η / SCOP | ηwh % / SCOP | 110/2,75 | 110/2,75 | 110/2,75 | 110/2,75 | 107/2,68 |
| DHW tank ERP cold climate η / SCOP | ηwh % / SCOP | 75/1,88 | 75/1,88 | 75/1,88 | 75/1,80 | 72/1,88 |
| Outdoor unit | | WH-UX09HE5 | WH-UX12HE5 | WH-UX09HE8 | WH-UX12HE8 | WH-UX16HE8 |
| Sound power part load ³⁾ | Heat | 66 | 66 | 65 | 65 | 67 |
| Sound power full load | Heat / Cool | 68/67 | 69/68 | 68/67 | 69/68 | 72/71 |
| Dimension / Net weight | HxWxD | 1340x900x320/101 | 1340x900x320/101 | 1340x900x320/108 | 1340x900x320/108 | 1340x900x320/118 |
| Refrigerant [R410A] / CO ₂ Eq. | kg / T | 2,85/5,951 | 2,85/5,951 | 2,85/5,951 | 2,85/5,951 | 2,90/6,055 |
| Pipe diameter | Liquid / Gas | Inch (mm) | 3/8(9,52)/5/8(15,88) | 3/8(9,52)/5/8(15,88) | 3/8(9,52)/5/8(15,88) | 3/8(9,52)/5/8(15,88) |
| Pipe length range / Elevation difference (in/out) | m / m | 3~30/20 | 3~30/20 | 3~30/20 | 3~30/20 | 3~30/20 |
| Pipe length for additional gas / Additional gas amount | m / g/m | 10/50 | 10/50 | 10/50 | 10/50 | 10/50 |
| Operation range | Outdoor ambient | °C | -28~+35 | -28~+35 | -28~+35 | -28~+35 |
| Water outlet | Heat / Cool | °C | 20~60/5~20 | 20~60/5~20 | 20~60/5~20 | 20~60/5~20 |

Accessories (optional)

| | |
|-------------------------|--|
| PAW-ADC-PREKIT-H | Piping pre installation kit for H Generation |
| PAW-ADC-CV150 | Decorative magnetic side cover |
| CZ-TAW1 | Aquarea Smart Cloud for remote control and maintenance through wireless or wired LAN |

Accessories (optional)

| | |
|---------------------------|------------------------------|
| CZ-NS4P | Additional functions PCB |
| PAW-A2W-RTWIRED | Room thermostat |
| PAW-A2W-RTWIRELESS | Wireless LCD room thermostat |

1) Scale from A+++ to D. 2) Scale from A+ to F. 3) Sound power in accordance to 8112013,81312013 and EN12102-1:2017 at +7 °C.

EER and COP calculation is based in accordance to EN14511.

This product is designed to comply with the European Water Quality Directive 98/83/EC amended by 2015/1787/EU. The lifespan of the product is not guaranteed in the case of the use of groundwater, such as spring water or well water, the use of tap water when salt or other impurities are contained, nor in areas of acidic water quality. Maintenance and warranty costs related to these cases are the customer's responsibility.



INTERNET CONTROL: Optional. GOOD DESIGN AWARD 2017: Indoor units All in One and Bi-bloc H Generation awarded with the prestigious Good Design Award 2017.

Aquarea T-CAP All in One H Generation Three Phase. Super Quiet outdoor unit. Heating and Cooling • R410A refrigerant



**GOOD
DESIGN**

Technical focus

Works at temperatures as low as -28 °C — Constant capacity up to -20 °C — Reduced installation costs — Reduced installation time and minimised installation errors — Easy remote controller to set up — Electrical connections at the front — Easier installation and maintenance — Remote controller functions (cooling mode activation possible by software. This activation can only be done by service partner)

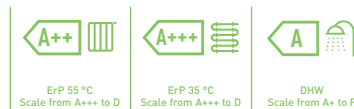

CZ-TAW1
Cloud connection.
For user control
and installer
remote
maintenance.

Three Phase (Power to indoor)

| Kit | | | KIT-AQC09HE8 | KIT-AQC12HE8 | KIT-AQC16HE8 |
|--|-----------------------|--------------|-----------------------|-----------------------|-----------------------|
| Heating capacity / COP (A +7 °C, W 35 °C) | kW / COP | | 9,00/4,84 | 12,00/4,74 | 16,00/4,28 |
| Heating capacity / COP (A +7 °C, W 55 °C) | kW / COP | | 9,00/2,94 | 12,00/2,88 | 16,00/2,71 |
| Heating capacity / COP (A +2 °C, W 35 °C) | kW / COP | | 9,00/3,59 | 12,00/3,44 | 16,00/3,10 |
| Heating capacity / COP (A +2 °C, W 55 °C) | kW / COP | | 9,00/2,21 | 12,00/2,19 | 16,00/2,13 |
| Heating capacity / COP (A -7 °C, W 35 °C) | kW / COP | | 9,00/2,85 | 12,00/2,72 | 16,00/2,49 |
| Heating capacity / COP (A -7 °C, W 55 °C) | kW / COP | | 9,00/2,02 | 12,00/1,92 | 16,00/1,86 |
| Cooling capacity / EER (A 35 °C, W 7 °C) | kW / EER | | 7,00/3,17 | 10,00/2,81 | 12,20/2,57 |
| Cooling capacity / EER (A 35 °C, W 18 °C) | kW / EER | | 7,00/5,19 | 10,00/5,13 | 12,20/3,49 |
| Seasonal energy efficiency - Heating average climate (W35 °C / W55 °C) | ηs % | | 181/130 | 170/130 | 160/125 |
| Energy class heating average climate (W35 °C / W55 °C) ¹⁾ | | A+++ to D | A+++ to D | A+++ to D | A+++ to D |
| Seasonal energy efficiency - Heating warm climate (W35 °C / W55 °C) | ηs % | | 235/158 | 231/158 | 231/159 |
| Energy class heating warm climate (W35 °C / W55 °C) ¹⁾ | | A+++ to D | A+++ to D | A+++ to D | A+++ to D |
| Seasonal energy efficiency - Heating cold climate (W35 °C / W55 °C) | ηs % | | 160/125 | 160/125 | 150/125 |
| Energy class heating cold climate (W35 °C / W55 °C) ¹⁾ | | A+++ to D | A+++ to D | A+++ to D | A+++ to D |
| Indoor unit | | | WH-ADC0916H9E8 | WH-ADC0916H9E8 | WH-ADC0916H9E8 |
| Sound pressure | Heat / Cool | dB(A) | 33/33 | 33/33 | 33/33 |
| Dimension / Net weight | HxWxD | mm / kg | 1800x598x717/126 | 1800x598x717/126 | 1800x598x717/126 |
| Water pipe connector | | Inch | R 1½ | R 1½ | R 1½ |
| A class pump | Number of speeds | | Variable Speed | Variable Speed | Variable Speed |
| | Input power (Min/Max) | W | 36/152 | 36/152 | 36/152 |
| Heating water flow (ΔT=5 K, 35 °C) | | L/min | 25,8 | 34,4 | 45,9 |
| Capacity of integrated electric heater | | kW | 9 | 9 | 9 |
| Recommended fuse | | A | 16/16 | 16/16 | 16/16 |
| Recommended cable size, supply 1 / 2 | | mm² | 5x1,5/5x1,5 | 5x1,5/5x1,5 | 5x1,5/5x1,5 |
| Water volume | | L | 185 | 185 | 185 |
| Maximum water temperature | | °C | 65 | 65 | 65 |
| Material inside tank | | | Stainless steel | Stainless steel | Stainless steel |
| Tapping profile according EN16147 | | | L | L | L |
| DHW tank ERP average climate efficiency rating ²⁾ | | A+ to F | A | A | A |
| DHW tank ERP warm climate efficiency rating ²⁾ | | A+ to F | A | A | A |
| DHW tank ERP cold climate efficiency rating ²⁾ | | A+ to F | A | A | B |
| DHW tank ERP average climate η / SCOP | | ηwh % / SCOP | 95/2,38 | 95/2,38 | 91/2,28 |
| DHW tank ERP warm climate η / SCOP | | ηwh % / SCOP | 110/2,75 | 110/2,75 | 107/2,68 |
| DHW tank ERP cold climate η / SCOP | | ηwh % / SCOP | 75/1,88 | 75/1,80 | 72/2,35 |
| Outdoor unit | | | WH-UQ09HE8 | WH-UQ12HE8 | WH-UQ16HE8 |
| Sound power part load ³⁾ | Heat | dB(A) | 58 | 58 | 62 |
| Sound power full load | Heat / Cool | dB(A) | 61/63 | 62/64 | 65/68 |
| Dimension / Net weight | HxWxD | mm / kg | 1410x1283x320/151 | 1410x1283x320/151 | 1410x1283x320/161 |
| Refrigerant (R410A) / CO ₂ Eq. | | kg / T | 2,85/5,951 | 2,85/5,951 | 2,99/6,243 |
| Pipe diameter | Liquid / Gas | Inch (mm) | 3/8(9,52)/5/8(15,88) | 3/8(9,52)/5/8(15,88) | 3/8(9,52)/5/8(15,88) |
| Pipe length range / Elevation difference (in/out) | | m / m | 3-30/20 | 3-30/20 | 3-30/20 |
| Pipe length for additional gas / Additional gas amount | | m / g/m | 10/50 | 10/50 | 10/50 |
| Operation range | Outdoor ambient | °C | -28 ~ +35 | -28 ~ +35 | -28 ~ +35 |
| Water outlet | Heat / Cool | °C | 20-60/5-20 | 20-60/5-20 | 20-60/5-20 |

Accessories (optional)

| | |
|-------------------------|--|
| PAW-ADC-PREKIT-H | Piping pre installation kit for H Generation |
| PAW-ADC-CV150 | Decorative magnetic side cover |
| CZ-TAW1 | Aquarea Smart Cloud for remote control and maintenance through wireless or wired LAN |

Accessories (optional)

| | |
|----------------------------|------------------------------|
| CZ-NS4P | Additional functions PCB |
| PAW-A2W-RTWIRED | Room thermostat |
| PAW-A2W-RTWIREDLESS | Wireless LCD room thermostat |

¹⁾ Scale from A+++ to D. ²⁾ Scale from A+ to F. ³⁾ Sound power in accordance to 8112013,81312013 and EN12102-1:2017 at +7 °C.

EER and COP calculation is based in accordance to EN14511.

This product is designed to comply with the European Water Quality Directive 98/83/EC amended by 2015/1787/EU. The lifespan of the product is not guaranteed in the case of the use of groundwater, such as spring water or well water, the use of tap water when salt or other impurities are contained, nor in areas of acidic water quality. Maintenance and warranty costs related to these cases are the customer's responsibility.



INTERNET CONTROL: Optional. GOOD DESIGN AWARD 2017: Indoor units All in One and Bi-bloc H Generation awarded with the prestigious Good Design Award 2017.

Aquarea High Performance Bi-bloc H Generation Single Phase. Heating and Cooling - SDC • R410A refrigerant



Technical focus

Very high energy savings A+++ (*) — Simple installation & maintenance — Special software for low consumption homes with minimum output temperature: 20 °C — Works at temperatures as low as -20 °C — Automatic Air purge valve — Display of the compressor frequency

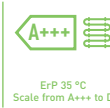
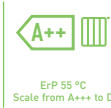

CZ-TAW1
Cloud connection.
For user control
and installer
remote
maintenance.

| | | | Single Phase Heating and Cooling | | | |
|--|-----------------------|-----------|----------------------------------|------------------------|------------------------|------------------------|
| Kit | | | KIT-WC03H3E5 | KIT-WC05H3E5 | KIT-WC07H3E5 | KIT-WC09H3E5 |
| Heating capacity / COP (A +7 °C, W 35 °C) | kW / COP | | 3,20/5,00 | 5,00/4,63 | 7,00/4,46 | 9,00/4,13 |
| Heating capacity / COP (A +7 °C, W 55 °C) | kW / COP | | 3,20/2,67 | 5,00/2,65 | 6,80/2,63 | 8,90/2,41 |
| Heating capacity / COP (A +2 °C, W 35 °C) | kW / COP | | 3,20/3,56 | 4,20/3,11 | 6,55/3,34 | 6,70/3,13 |
| Heating capacity / COP (A +2 °C, W 55 °C) | kW / COP | | 3,20/2,15 | 4,10/1,98 | 6,00/1,99 | 6,00/1,99 |
| Heating capacity / COP (A -7 °C, W 35 °C) | kW / COP | | 3,20/2,69 | 4,20/2,59 | 5,15/2,68 | 5,90/2,52 |
| Heating capacity / COP (A -7 °C, W 55 °C) | kW / COP | | 3,20/1,72 | 3,55/1,71 | 4,80/1,89 | 5,80/1,88 |
| Cooling capacity / EER (A 35 °C, W 7 °C) | kW / EER | | 3,20/3,08 | 4,50/2,69 | 6,00/2,63 | 7,00/2,43 |
| Cooling capacity / EER (A 35 °C, W 18 °C) | kW / EER | | 3,30/3,75 | 5,00/3,76 | 6,00/3,57 | 7,00/3,26 |
| Seasonal energy efficiency - Heating average climate (W35 °C / W55 °C) | ηs % | | 195/130 | 195/130 | 190/130 | 190/130 |
| | SCOP | | 4,95/3,33 | 4,95/3,33 | 4,83/3,33 | 4,83/3,33 |
| Energy class heating average climate (W35 °C / W55 °C) | A+++ to D | | A+++ / A++ | A+++ / A++ | A+++ / A++ | A+++ / A++ |
| Seasonal energy efficiency - Heating warm climate (W35 °C / W55 °C) | ηs % | | 244/163 | 244/163 | 225/160 | 225/160 |
| | SCOP | | 6,18/4,15 | 6,18/4,15 | 5,70/4,08 | 5,70/4,08 |
| Energy class heating warm climate (W35 °C / W55 °C) | A+++ to D | | A+++ / A+++ | A+++ / A+++ | A+++ / A+++ | A+++ / A+++ |
| Seasonal energy efficiency - Heating cold climate (W35 °C / W55 °C) | ηs % | | 150/103 | 150/103 | 160/115 | 160/115 |
| | SCOP | | 3,83/2,65 | 3,83/2,65 | 4,08/2,95 | 4,08/2,95 |
| Energy class heating cold climate (W35 °C / W55 °C) | A+++ to D | | A++ / A+ | A++ / A+ | A++ / A+ | A++ / A+ |
| Indoor unit | | | WH-SDC03H3E5-1 | WH-SDC05H3E5-1 | WH-SDC07H3E5-1 | WH-SDC09H3E5-1 |
| Sound pressure | Heat / Cool | dB(A) | 28/28 | 28/28 | 30/30 | 30/30 |
| Dimension | H x W x D | mm | 892 x 500 x 340 | 892 x 500 x 340 | 892 x 500 x 340 | 892 x 500 x 340 |
| Net weight | | kg | 44 | 44 | 44 | 44 |
| Water pipe connector | | Inch | R 1½ | R 1½ | R 1½ | R 1½ |
| A class pump | Number of speeds | | Variable Speed | Variable Speed | Variable Speed | Variable Speed |
| | Input power (Min/Max) | W | 30/100 | 33/106 | 34/114 | 40/120 |
| Heating water flow (ΔT=5 K, 35 °C) | | L/min | 9,2 | 14,3 | 20,1 | 25,8 |
| Capacity of integrated electric heater | | kW | 3 | 3 | 3 | 3 |
| Recommended fuse | | A | 15/30 | 15/30 | 15/30 | 15/30 |
| Recommended cable size, supply 1 / 2 | | mm | 3 x 1,5/3 x 1,5 | 3 x 1,5/3 x 1,5 | 3 x 1,5/3 x 1,5 | 3 x 1,5/3 x 1,5 |
| Outdoor unit | | | WH-UD03HE5-1 | WH-UD05HE5-1 | WH-UD07HE5-1 | WH-UD09HE5-1 |
| Sound power part load ¹⁾ | Heat | dB(A) | 55 | 55 | 59 | 59 |
| Sound power full load | Heat / Cool | dB(A) | 64/65 | 65/66 | 68/66 | 69/68 |
| Dimension | H x W x D | mm | 622 x 824 x 298 | 622 x 824 x 298 | 795 x 900 x 320 | 795 x 900 x 320 |
| Net weight | | kg | 39 | 39 | 66 | 66 |
| Refrigerant (R410A) / CO ₂ Eq. | | kg / T | 1,20/2,506 | 1,20/2,506 | 1,45/3,028 | 1,45/3,028 |
| Pipe diameter | Liquid / Gas | Inch (mm) | 1/4 (6,35)/1/2 (12,70) | 1/4 (6,35)/1/2 (12,70) | 1/4 (6,35)/5/8 (15,88) | 1/4 (6,35)/5/8 (15,88) |
| Pipe length range | | m | 3 ~ 15 | 3 ~ 15 | 3 ~ 40 | 3 ~ 40 |
| Elevation difference (in/out) | | m | 5 | 5 | 30 | 30 |
| Pipe length for additional gas | | m | 10 | 10 | 10 | 10 |
| Additional gas amount | | g/m | 20 | 20 | 30 | 30 |
| Operation range | Outdoor ambient | °C | -20 ~ +35 | -20 ~ +35 | -20 ~ +35 | -20 ~ +35 |
| Water outlet | Heat / Cool | °C | 20 ~ 55/5 ~ 20 | 20 ~ 55/5 ~ 20 | 20 ~ 55/5 ~ 20 | 20 ~ 55/5 ~ 20 |

Accessories (optional)

| | |
|------------------------|--|
| PAW-TD20C1E5 | Tank 200L - Stainless steel |
| PAW-TD30C1E5 | Tank 300L - Stainless steel |
| PAW-TA20C1E5STD | Tank 200L - Enamelled |
| PAW-TA30C1E5STD | Tank 300L - Enamelled |
| PAW-3WYVLV-HW | 3 way valve for DHW Tanks |
| CZ-NV1 | 3 way valve kit for inside of hydrokit |

Accessories (optional)

| | |
|---------------------------|--|
| PAW-BTANK50L-2 | Buffer tank 50L |
| CZ-TAW1 | Aquarea Smart Cloud for remote control and maintenance through wireless or wired LAN |
| CZ-NS4P | Additional functions PCB |
| PAW-A2W-RTWIRED | Room thermostat |
| PAW-A2W-RTWIRELESS | Wireless LCD room thermostat |

1) Sound power in accordance to 8112013,81312013 and EN12102-1:2017 at +7 °C. EER and COP calculation is based in accordance to EN14511.



INTERNET CONTROL: Optional. GOOD DESIGN AWARD 2017: Indoor units All in One and Bi-bloc H Generation awarded with the prestigious Good Design Award 2017.

Aquarea High Performance Bi-bloc H Generation Single Phase / Three Phase. Heating and Cooling - SDC

• R410A refrigerant



Technical focus

Very high energy savings A+++ (*) — Simple installation & maintenance — Special software for low consumption homes with minimum output temperature: 20 °C — Works at temperatures as low as -20 °C — Automatic Air purge valve — Display of the compressor frequency

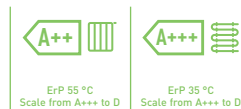

CZ-TAW1
Cloud connection.
For user control
and installer
remote
maintenance.

| Kit | Single Phase Heating and Cooling | | | | Three Phase (Power to indoor) | | | |
|--|----------------------------------|---------------------|---------------------|----------------------|-------------------------------|----------------------|----------------------|----------------------|
| | KIT-WC12H6E5 | KIT-WC16H6E5 | KIT-WC09H3E8 | KIT-WC12H9E8 | KIT-WC16H9E8 | | | |
| Heating capacity / COP (A +7 °C, W 35 °C) | kW / COP | 12,00/4,74 | 16,00/4,28 | 9,00/4,84 | 12,00/4,74 | 16,00/4,28 | | |
| Heating capacity / COP (A +7 °C, W 55 °C) | kW / COP | 12,00/2,88 | 14,50/2,68 | 9,00/2,94 | 12,00/2,88 | 14,50/2,68 | | |
| Heating capacity / COP (A +2 °C, W 35 °C) | kW / COP | 11,40/3,44 | 13,00/3,28 | 9,00/3,59 | 11,40/3,44 | 13,00/3,28 | | |
| Heating capacity / COP (A +2 °C, W 55 °C) | kW / COP | 9,10/2,20 | 9,80/2,17 | 8,80/2,23 | 9,10/2,20 | 9,80/2,17 | | |
| Heating capacity / COP (A -7 °C, W 35 °C) | kW / COP | 10,00/2,73 | 11,40/2,57 | 9,00/2,85 | 10,00/2,73 | 11,40/2,57 | | |
| Heating capacity / COP (A -7 °C, W 55 °C) | kW / COP | 8,20/1,92 | 9,00/1,82 | 7,90/2,05 | 8,20/1,92 | 9,00/1,82 | | |
| Cooling capacity / EER (A 35 °C, W 7 °C) | kW / EER | 10,00/2,81 | 12,20/2,56 | 7,00/3,17 | 10,00/2,81 | 12,20/2,56 | | |
| Cooling capacity / EER (A 35 °C, W 18 °C) | kW / EER | 10,00/4,17 | 12,20/4,12 | 7,00/4,61 | 10,00/4,17 | 12,20/4,12 | | |
| Seasonal energy efficiency - Heating average climate (W35 °C / W55 °C) | ηs % | 190/134 | 190/130 | 190/133 | 190/134 | 190/130 | | |
| | SCOP | 4,83/3,43 | 4,83/3,33 | 4,83/3,40 | 4,83/3,43 | 4,83/3,33 | | |
| Energy class heating average climate (W35 °C / W55 °C) | A+++ to D | A+++/A++ | A+++/A++ | A+++/A++ | A+++/A++ | A+++/A++ | | |
| Seasonal energy efficiency - Heating warm climate (W35 °C / W55 °C) | ηs % | 245/159 | 245/169 | 245/159 | 245/159 | 245/169 | | |
| | SCOP | 6,20/4,05 | 6,20/4,30 | 6,20/4,05 | 6,20/4,05 | 6,20/4,30 | | |
| Energy class heating warm climate (W35 °C / W55 °C) | A+++ to D | A+++/A+++ | A+++/A+++ | A+++/A+++ | A+++/A+++ | A+++/A+++ | | |
| Seasonal energy efficiency - Heating cold climate (W35 °C / W55 °C) | ηs % | 168/121 | 168/121 | 168/121 | 168/121 | 168/121 | | |
| | SCOP | 4,28/3,10 | 4,28/3,10 | 4,28/3,10 | 4,28/3,10 | 4,28/3,10 | | |
| Energy class heating cold climate (W35 °C / W55 °C) | A+++ to D | A++/A+ | A++/A+ | A++/A+ | A++/A+ | A++/A+ | | |
| Indoor unit | | WH-SDC12H6E5 | WH-SDC16H6E5 | WH-SDC09H3E8 | WH-SDC12H9E8 | WH-SDC16H9E8 | | |
| Sound pressure | Heat / Cool | dB(A) | | 33/33 | 33/33 | 33/33 | | |
| Dimension | HxWxD | mm | | 892x500x340 | 892x500x340 | 892x500x340 | | |
| Net weight | | kg | | 44 | 45 | 45 | | |
| Water pipe connector | | Inch | | R 1½ | R 1½ | R 1½ | | |
| A class pump | Number of speeds | Variable Speed | | Variable Speed | Variable Speed | Variable Speed | | |
| | Input power (Min/Max) | W | | 34/110 | 30/105 | 32/102 | 34/110 | 30/105 |
| Heating water flow (ΔT=5 K, 35 °C) | | L/min | | 34,4 | 45,9 | 25,8 | 34,4 | 45,9 |
| Capacity of integrated electric heater | | kW | | 6 | 6 | 3 | 9 | 9 |
| Recommended fuse | | A | | 30/30 | 30/30 | 15/30 | 15/30 | 15/30 |
| Recommended cable size, supply 1 / 2 | | mm | | 3x4,0 or 6,0/3x4,0 | 3x4,0 or 6,0/3x4,0 | 5x1,5/5x1,5 | 5x1,5/5x1,5 | 5x1,5/5x1,5 |
| Outdoor unit | | WH-UD12H6E5 | WH-UD16H6E5 | WH-UD09H3E8 | WH-UD12H9E8 | WH-UD16H9E8 | | |
| Sound power part load ¹⁾ | Heat | dB(A) | | 65 | 65 | 65 | 65 | 65 |
| Sound power full load | Heat / Cool | dB(A) | | 69/68 | 72/72 | 68/67 | 69/68 | 72/72 |
| Dimension | HxWxD | mm | | 1340x900x320 | 1340x900x320 | 1340x900x320 | 1340x900x320 | 1340x900x320 |
| Net weight | | kg | | 101 | 101 | 107 | 107 | 107 |
| Refrigerant (R410A) / CO ₂ Eq. | | kg / T | | 2,55/5,324 | 2,55/5,324 | 2,55/5,324 | 2,55/5,324 | 2,55/5,324 |
| Pipe diameter | Liquid / Gas | Inch (mm) | | 3/8(9,52)/5/8(15,88) | 3/8(9,52)/5/8(15,88) | 3/8(9,52)/5/8(15,88) | 3/8(9,52)/5/8(15,88) | 3/8(9,52)/5/8(15,88) |
| Pipe length range | | m | | 3~50 | 3~50 | 3~30 | 3~30 | 3~30 |
| Elevation difference (in/out) | | m | | 30 | 30 | 20 | 20 | 20 |
| Pipe length for additional gas | | m | | 10 | 10 | 10 | 10 | 10 |
| Additional gas amount | | g/m | | 50 | 50 | 50 | 50 | 50 |
| Operation range | Outdoor ambient | °C | | -20~+35 | -20~+35 | -20~+35 | -20~+35 | -20~+35 |
| Water outlet | Heat / Cool | °C | | 20~55/5~20 | 20~55/5~20 | 20~55/5~20 | 20~55/5~20 | 20~55/5~20 |

Accessories (optional)

| | |
|------------------------|--|
| PAW-TD20C1E5 | Tank 200L - Stainless steel |
| PAW-TD30C1E5 | Tank 300L - Stainless steel |
| PAW-TA20C1E5STD | Tank 200L - Enamelled |
| PAW-TA30C1E5STD | Tank 300L - Enamelled |
| PAW-3WYVLV-HW | 3 way valve for DHW Tanks |
| CZ-NV1 | 3 way valve kit for inside of hydrokit |

Accessories (optional)

| | |
|---------------------------|--|
| PAW-BTANK50L-2 | Buffer tank 50L |
| CZ-TAW1 | Aquarea Smart Cloud for remote control and maintenance through wireless or wired LAN |
| CZ-NS4P | Additional functions PCB |
| PAW-A2W-RTWIRED | Room thermostat |
| PAW-A2W-RTWIRELESS | Wireless LCD room thermostat |

1) Sound power in accordance to 8112013,81312013 and EN12102-1:2017 at +7 °C. EER and COP calculation is based in accordance to EN14511.



INTERNET CONTROL: Optional. GOOD DESIGN AWARD 2017: Indoor units All in One and Bi-bloc H Generation awarded with the prestigious Good Design Award 2017.

Aquarea T-CAP Bi-bloc H Generation Single Phase / Three Phase. Heating and Cooling - SXC • R410A refrigerant



GOOD DESIGN

Technical focus

Very high energy savings A++ — Simple installation & maintenance — Constant capacity up to -20 °C — Water temperature up to 60 °C — Special software for low consumption homes with minimum output temperature: 20 °C — Works at temperatures as low as -28 °C — Automatic Air purge valve — Display of the compressor frequency

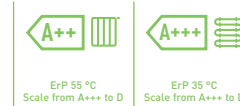

CZ-TAW1
Cloud connection.
For user control
and installer
remote
maintenance.

| Kit | Single Phase (Power to indoor) | | | Three Phase (Power to indoor) | | |
|--|--------------------------------|---------------------|----------------------|-------------------------------|----------------------|----------------------|
| | KIT-WXC09H3E5 | KIT-WXC12H6E5 | KIT-WXC09H3E8 | KIT-WXC12H9E8 | KIT-WXC16H9E8 | |
| Heating capacity / COP (A +7 °C, W 35 °C) | kW / COP | 9,00/4,84 | 12,00/4,74 | 9,00/4,84 | 12,00/4,74 | 16,00/4,28 |
| Heating capacity / COP (A +7 °C, W 55 °C) | kW / COP | 9,00/2,94 | 12,00/2,88 | 9,00/2,94 | 12,00/2,88 | 16,00/2,71 |
| Heating capacity / COP (A +2 °C, W 35 °C) | kW / COP | 9,00/3,59 | 12,00/3,44 | 9,00/3,59 | 12,00/3,44 | 16,00/3,10 |
| Heating capacity / COP (A +2 °C, W 55 °C) | kW / COP | 9,00/2,21 | 12,00/2,19 | 9,00/2,21 | 12,00/2,19 | 16,00/2,13 |
| Heating capacity / COP (A -7 °C, W 35 °C) | kW / COP | 9,00/2,85 | 12,00/2,72 | 9,00/2,85 | 12,00/2,72 | 16,00/2,49 |
| Heating capacity / COP (A -7 °C, W 55 °C) | kW / COP | 9,00/2,02 | 12,00/1,92 | 9,00/2,02 | 12,00/1,92 | 16,00/1,86 |
| Cooling capacity / EER (A 35 °C, W 7 °C) | kW / EER | 7,00/3,17 | 10,00/2,81 | 7,00/3,17 | 10,00/2,81 | 12,20/2,57 |
| Cooling capacity / EER (A 35 °C, W 18 °C) | kW / EER | 7,00/5,19 | 10,00/5,13 | 7,00/5,19 | 10,00/5,13 | 12,20/3,49 |
| Seasonal energy efficiency - Heating average climate (W35 °C / W55 °C) | ηs % | 181/130 | 170/130 | 181/130 | 170/130 | 160/125 |
| | SCOP | 4,60/3,33 | 4,33/3,33 | 4,60/3,33 | 4,33/3,33 | 4,08/3,20 |
| Energy class heating average climate (W35 °C / W55 °C) | A+++ to D | A+++ / A++ | A++ / A++ | A+++ / A++ | A++ / A++ | A++ / A++ |
| Seasonal energy efficiency - Heating warm climate (W35 °C / W55 °C) | ηs % | 235/158 | 231/158 | 235/158 | 231/158 | 231/159 |
| | SCOP | 5,95/4,03 | 5,85/4,03 | 5,95/4,03 | 5,85/4,03 | 5,85/4,05 |
| Energy class heating warm climate (W35 °C / W55 °C) | A+++ to D | A+++ / A+++ | A+++ / A+++ | A+++ / A+++ | A+++ / A+++ | A+++ / A+++ |
| Seasonal energy efficiency - Heating cold climate (W35 °C / W55 °C) | ηs % | 160/125 | 160/125 | 160/125 | 160/125 | 150/125 |
| | SCOP | 4,08/3,20 | 4,08/3,20 | 4,08/3,20 | 4,08/3,20 | 3,83/3,20 |
| Energy class heating cold climate (W35 °C / W55 °C) | A+++ to D | A++ / A++ | A++ / A++ | A++ / A++ | A++ / A++ | A++ / A++ |
| Indoor unit | | WH-SXC09H3E5 | WH-SXC12H6E5 | WH-SXC09H3E8 | WH-SXC12H9E8 | WH-SXC16H9E8 |
| Sound pressure | Heat / Cool | dB(A) | 33/33 | 33/33 | 33/33 | 33/33 |
| Dimension | HxWxD | mm | 892x500x340 | 892x500x340 | 892x500x340 | 892x500x340 |
| Net weight | | kg | 43 | 43 | 43 | 44 |
| Water pipe connector | | Inch | R 1½ | R 1½ | R 1½ | R 1½ |
| A class pump | Number of speeds | | Variable Speed | Variable Speed | Variable Speed | Variable Speed |
| | Input power (Min/Max) | W | 32/102 | 34/110 | 32/102 | 34/110 |
| Heating water flow (ΔT=5 K, 35 °C) | | L/min | 25,8 | 34,4 | 25,8 | 34,4 |
| Capacity of integrated electric heater | | kW | 3 | 6 | 3 | 9 |
| Recommended fuse | | A | 30/30 | 30/30 | 16/16 | 16/16 |
| Recommended cable size, supply 1 / 2 | | mm | 3x4,0 or 6,0/3x4,0 | 3x4,0 or 6,0/3x4,0 | 5x1,5/3x1,5 | 5x1,5/5x1,5 |
| Outdoor unit | | | WH-UX09HE5 | WH-UX12HE5 | WH-UX09HE8 | WH-UX12HE8 |
| Sound power part load ¹⁾ | Heat | dB(A) | 66 | 66 | 65 | 65 |
| Sound power full load | Heat / Cool | dB(A) | 68/67 | 69/68 | 68/67 | 69/68 |
| Dimension | HxWxD | mm | 1340x900x320 | 1340x900x320 | 1340x900x320 | 1340x900x320 |
| Net weight | | kg | 101 | 101 | 108 | 108 |
| Refrigerant (R410A) / CO ₂ Eq. | | kg / T | 2,85/5,951 | 2,85/5,951 | 2,85/5,951 | 2,85/5,951 |
| Pipe diameter | Liquid / Gas | Inch (mm) | 3/8(9,52)/5/8(15,88) | 3/8(9,52)/5/8(15,88) | 3/8(9,52)/5/8(15,88) | 3/8(9,52)/5/8(15,88) |
| Pipe length range | | m | 3-30 | 3-30 | 3-30 | 3-30 |
| Elevation difference (in/out) | | m | 30 | 30 | 30 | 30 |
| Pipe length for additional gas | | m | 10 | 10 | 10 | 10 |
| Additional gas amount | | g/m | 50 | 50 | 50 | 50 |
| Operation range | Outdoor ambient | °C | -28 ~ +35 | -28 ~ +35 | -28 ~ +35 | -28 ~ +35 |
| Water outlet | Heat / Cool | °C | 20-60/5-20 | 20-60/5-20 | 20-60/5-20 | 20-60/5-20 |

Accessories (optional)

| | |
|------------------------|--|
| PAW-TD20C1E5 | Tank 200L - Stainless steel |
| PAW-TD30C1E5 | Tank 300L - Stainless steel |
| PAW-TA20C1E5STD | Tank 200L - Enamelled |
| PAW-TA30C1E5STD | Tank 300L - Enamelled |
| PAW-3WYVLV-HW | 3 way valve for DHW Tanks |
| CZ-NV1 | 3 way valve kit for inside of hydrokit |

Accessories (optional)

| | |
|---------------------------|--|
| PAW-BTANK50L-2 | Buffer tank 50L |
| CZ-TAW1 | Aquarea Smart Cloud for remote control and maintenance through wireless or wired LAN |
| CZ-NS4P | Additional functions PCB |
| PAW-A2W-RTWIRED | Room thermostat |
| PAW-A2W-RTWIRELESS | Wireless LCD room thermostat |

1) Sound power in accordance to 8112013,81312013 and EN12102-1:2017 at +7 °C. EER and COP calculation is based in accordance to EN14511.



INTERNET CONTROL: Optional. GOOD DESIGN AWARD 2017: Indoor units All in One and Bi-bloc H Generation awarded with the prestigious Good Design Award 2017.

Aquarea T-CAP Bi-bloc H Generation Three Phase. Super Quiet outdoor unit. Heating and Cooling - SQC

• R410A Gas



GOOD DESIGN

Technical focus

Very high energy savings A++ — Noise reduction of 7 dB is based on power level when heating mode — With Quiet mode we can reach 10 ~ 12 dB(A) — Constant capacity up to -20 °C — Water temperature up to 60 °C — Special software for low consumption homes with minimum output temperature: 20 °C — Works at temperatures as low as -28 °C — Display of the compressor frequency

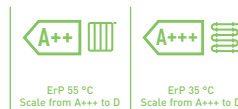

CZ-TAW1
Cloud connection.
For user control
and installer
remote
maintenance.

Three Phase (Power to indoor)

| Kit | | | KIT-WQC09H3E8 | KIT-WQC12H9E8 | KIT-WQC16H9E8 |
|--|-----------------------|-----------|----------------------|----------------------|----------------------|
| Heating capacity / COP (A +7 °C, W 35 °C) | | kW / COP | 9,00/4,84 | 12,00/4,74 | 16,00/4,28 |
| Heating capacity / COP (A +7 °C, W 55 °C) | | kW / COP | 9,00/2,94 | 12,00/2,88 | 16,00/2,71 |
| Heating capacity / COP (A +2 °C, W 35 °C) | | kW / COP | 9,00/3,59 | 12,00/3,44 | 16,00/3,10 |
| Heating capacity / COP (A +2 °C, W 55 °C) | | kW / COP | 9,00/2,21 | 12,00/2,19 | 16,00/2,13 |
| Heating capacity / COP (A -7 °C, W 35 °C) | | kW / COP | 9,00/2,85 | 12,00/2,72 | 16,00/2,49 |
| Heating capacity / COP (A -7 °C, W 55 °C) | | kW / COP | 9,00/2,02 | 12,00/1,92 | 16,00/1,86 |
| Cooling capacity / EER (A 35 °C, W 7 °C) | | kW / EER | 7,00/3,17 | 10,00/2,81 | 12,20/2,57 |
| Cooling capacity / EER (A 35 °C, W 18 °C) | | kW / EER | 7,00/5,19 | 10,00/5,13 | 12,20/3,49 |
| Seasonal energy efficiency - Heating average climate (W35 °C / W55 °C) | | ηs % | 181/130 | 170/130 | 160/125 |
| | | SCOP | 4,60/3,33 | 4,33/3,33 | 4,08/3,20 |
| Energy class heating average climate (W35 °C / W55 °C) | | A+++ to D | A+++/A++ | A++/A++ | A++/A++ |
| Seasonal energy efficiency - Heating warm climate (W35 °C / W55 °C) | | ηs % | 235/158 | 231/158 | 231/159 |
| | | SCOP | 5,95/4,03 | 5,85/4,03 | 5,85/4,05 |
| Energy class heating warm climate (W35 °C / W55 °C) | | A+++ to D | A+++/A+++ | A+++/A+++ | A+++/A+++ |
| Seasonal energy efficiency - Heating cold climate (W35 °C / W55 °C) | | ηs % | 160/125 | 160/125 | 150/125 |
| | | SCOP | 4,08/3,20 | 4,08/3,20 | 3,83/3,20 |
| Energy class heating cold climate (W35 °C / W55 °C) | | A+++ to D | A++/A++ | A++/A++ | A++/A++ |
| Indoor unit | | | WH-SQC09H3E8 | WH-SQC12H9E8 | WH-SQC16H9E8 |
| Sound pressure | Heat / Cool | dB(A) | 33/33 | 33/33 | 33/33 |
| Dimension | HxWxD | mm | 892x500x340 | 892x500x340 | 892x500x340 |
| Net weight | | kg | 43 | 44 | 45 |
| Water pipe connector | | Inch | R 1½ | R 1½ | R 1½ |
| A class pump | Number of speeds | | Variable Speed | Variable Speed | Variable Speed |
| | Input power (Min/Max) | W | 32/102 | 34/110 | 30/105 |
| Heating water flow (ΔT=5 K, 35 °C) | | L/min | 25,8 | 34,4 | 45,9 |
| Capacity of integrated electric heater | | kW | 3 | 9 | 9 |
| Recommended fuse | | A | 15/30 | 15/30 | 15/30 |
| Recommended cable size, supply 1 / 2 | | mm | 5x1,5/3x1,5 | 5x1,5/5x1,5 | 5x1,5/5x1,5 |
| Outdoor unit | | | WH-UQ09H8 | WH-UQ12H8 | WH-UQ16H8 |
| Sound power part load ¹⁾ | Heat | dB(A) | 58 | 58 | 62 |
| Sound power full load | Heat / Cool | dB(A) | 61/63 | 62/64 | 65/68 |
| Dimension | HxWxD | mm | 1410x1283x320 | 1410x1283x320 | 1410x1283x320 |
| Net weight | | kg | 151 | 151 | 161 |
| Refrigerant (R410A) / CO ₂ Eq. | | kg / T | 2,85/5,951 | 2,85/5,951 | 2,99/6,243 |
| Pipe diameter | Liquid / Gas | Inch (mm) | 3/8(9,52)/5/8(15,88) | 3/8(9,52)/5/8(15,88) | 3/8(9,52)/5/8(15,88) |
| Pipe length range | | m | 3-30 | 3-30 | 3-30 |
| Elevation difference (in/out) | | m | 20 | 20 | 20 |
| Pipe length for additional gas | | m | 10 | 10 | 10 |
| Additional gas amount | | g/m | 50 | 50 | 50 |
| Operation range | Outdoor ambient | °C | -28 ~ +35 | -28 ~ +35 | -28 ~ +35 |
| Water outlet | Heat / Cool | °C | 20-60/5-20 | 20-60/5-20 | 20-60/5-20 |

Accessories (optional)

| | |
|------------------------|--|
| PAW-TD20C1E5 | Tank 200L - Stainless steel |
| PAW-TD30C1E5 | Tank 300L - Stainless steel |
| PAW-TA20C1E5STD | Tank 200L - Enamelled |
| PAW-TA30C1E5STD | Tank 300L - Enamelled |
| PAW-3WYVLV-HW | 3 way valve for DHW Tanks |
| CZ-NV1 | 3 way valve kit for inside of hydrokit |

Accessories (optional)

| | |
|---------------------------|--|
| PAW-BTANK50L-2 | Buffer tank 50L |
| CZ-TAW1 | Aquarea Smart Cloud for remote control and maintenance through wireless or wired LAN |
| CZ-NS4P | Additional functions PCB |
| PAW-A2W-RTWIRED | Room thermostat |
| PAW-A2W-RTWIRELESS | Wireless LCD room thermostat |

1) Sound power in accordance to 8112013,81312013 and EN12102-1:2017 at +7 °C. EER and COP calculation is based in accordance to EN14511.



INTERNET CONTROL: Optional. GOOD DESIGN AWARD 2017: Indoor units All in One and Bi-bloc H Generation awarded with the prestigious Good Design Award 2017.

Aquarea High Performance Mono-bloc H Generation Single Phase. Heating and Cooling - MDC • R410A refrigerant

Technical focus

Optional Smartphone control — Maximum hydraulic module output temperature: 55 °C — Works at temperatures as low as -20 °C — Cooling temperature range 5 ~ 20 °C

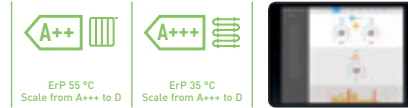

CZ-TAW1
Cloud connection.
For user control
and installer
remote
maintenance.

Single Phase Heating and Cooling

| Outdoor unit | | WH-MDC05H3E5 | WH-MDC07H3E5 | WH-MDC09H3E5 | WH-MDC12H6E5 | WH-MDC16H6E5 | |
|--|-----------------------|-----------------|--------------------|--------------------|--------------------|--------------------|--------------------|
| Heating capacity / COP [A +7 °C, W 35 °C] | kW / COP | 5,00/5,08 | 7,00/4,52 | 9,00/4,29 | 12,00/4,74 | 16,00/4,28 | |
| Heating capacity / COP [A +7 °C, W 55 °C] | kW / COP | 5,00/2,84 | 7,00/2,83 | 9,00/2,72 | 12,00/2,93 | 14,50/2,72 | |
| Heating capacity / COP [A +2 °C, W 35 °C] | kW / COP | 4,80/3,36 | 6,60/3,30 | 6,80/3,18 | 11,40/3,44 | 13,00/3,28 | |
| Heating capacity / COP [A +2 °C, W 55 °C] | kW / COP | 4,00/2,33 | 6,30/2,22 | 6,30/2,13 | 9,10/2,23 | 9,80/2,21 | |
| Heating capacity / COP [A -7 °C, W 35 °C] | kW / COP | 4,70/2,85 | 5,50/2,70 | 6,40/2,60 | 10,00/2,73 | 11,40/2,57 | |
| Heating capacity / COP [A -7 °C, W 55 °C] | kW / COP | 4,30/1,89 | 5,00/1,82 | 5,80/1,78 | 8,20/1,95 | 9,00/1,84 | |
| Cooling capacity / EER [A 35 °C, W 7 °C] | kW / EER | 4,50/3,28 | 6,00/2,78 | 7,00/2,60 | 10,00/2,81 | 12,20/2,56 | |
| Cooling capacity / EER [A 35 °C, W 18 °C] | kW / EER | 5,10/5,10 | 6,00/3,87 | 7,00/3,59 | 10,00/4,65 | 12,20/4,12 | |
| Seasonal energy efficiency - Heating average climate [W35 °C / W55 °C] | ηs % | 199/139 | 190/130 | 190/130 | 190/134 | 190/130 | |
| | SCOP | 5,05/3,55 | 4,83/3,33 | 4,83/3,33 | 4,83/3,43 | 4,83/3,33 | |
| Energy class heating average climate [W35 °C / W55 °C] | A+++ to D | A+++ / A++ | A+++ / A++ | A+++ / A++ | A+++ / A++ | A+++ / A++ | |
| Seasonal energy efficiency - Heating warm climate [W35 °C / W55 °C] | ηs % | 237/161 | 225/160 | 225/160 | 245/159 | 245/169 | |
| | SCOP | 6,00/4,10 | 5,70/4,08 | 5,70/4,08 | 6,20/4,05 | 6,20/4,30 | |
| Energy class heating warm climate [W35 °C / W55 °C] | A+++ to D | A+++ / A+++ | A+++ / A+++ | A+++ / A+++ | A+++ / A+++ | A+++ / A+++ | |
| Seasonal energy efficiency - Heating cold climate [W35 °C / W55 °C] | ηs % | 160/115 | 160/115 | 160/115 | 168/121 | 168/121 | |
| | SCOP | 4,08/2,95 | 4,08/2,95 | 4,08/2,95 | 4,28/3,10 | 4,28/3,10 | |
| Energy class heating cold climate [W35 °C / W55 °C] | A+++ to D | A++ / A+ | A++ / A+ | A++ / A+ | A++ / A+ | A++ / A+ | |
| Sound power part load ¹⁾ | Heat | 55 | 59 | 59 | 65 | 65 | |
| Sound power full load | Heat / Cool | 65/65 | 68/66 | 69/67 | 69/68 | 72/72 | |
| Dimension | H x W x D | mm | 865 x 1283 x 320 | 865 x 1283 x 320 | 865 x 1283 x 320 | 1410 x 1283 x 320 | |
| Net weight | | kg | 94 | 104 | 104 | 140 | |
| Refrigerant [R410A] / CO ₂ Eq. ²⁾ | | kg / T | 1,30/2714 | 1,35/2819 | 1,35/2819 | 2,10/4,385 | |
| Water pipe connector | | Inch | R1½ | R1½ | R1½ | R1½ | |
| Pump | Number of speeds | | Variable Speed | Variable Speed | Variable Speed | Variable Speed | |
| | Input power [Min/Max] | W | 34/96 | 36/100 | 39/108 | 34/110 | 38/120 |
| Heating water flow [ΔT=5 K, 35 °C] | | L/min | 14,3 | 20,1 | 25,8 | 34,4 | 45,9 |
| Capacity of integrated electric heater | | kW | 3 | 3 | 3 | 6 | 6 |
| Input Power | Heat | kW | 0,985 | 1,55 | 2,10 | 2,53 | 3,74 |
| | Cool | kW | 1,37 | 2,16 | 2,69 | 3,56 | 4,76 |
| Running and Starting current | Heat | A | 4,7 | 7,2 | 9,6 | 11,7 | 16,9 |
| | Cool | A | 6,3 | 9,9 | 12,2 | 16,2 | 21,5 |
| Current 1 | | A | 13,0 | 21,0 | 22,9 | 24,0 | 26,0 |
| Current 2 | | A | 13,0 | 13,0 | 13,0 | 26,0 | 26,0 |
| Recommended fuse | | A | 30/15 | 30/15 | 30/16 | 30/30 | 30/30 |
| Recommended cable size, supply 1 / 2 | | mm ² | 3x4,0 or 6,0/3x4,0 | 3x4,0 or 6,0/3x4,0 | 3x4,0 or 6,0/3x4,0 | 3x4,0 or 6,0/3x4,0 | 3x4,0 or 6,0/3x4,0 |
| Operation range | Outdoor ambient | °C | -20 ~ +35 | -20 ~ +35 | -20 ~ +35 | -20 ~ +35 | -20 ~ +35 |
| Water outlet | Heat | °C | 20 ~ 55 | 20 ~ 55 | 20 ~ 55 | 25 ~ 55 | 25 ~ 55 |
| | Cool | °C | 5 ~ 20 | 5 ~ 20 | 5 ~ 20 | 5 ~ 20 | 5 ~ 20 |

Accessories (optional)

| | |
|------------------------|---|
| PAW-TD20C1E5 | Tank 200L - Stainless steel |
| PAW-TD30C1E5 | Tank 300L - Stainless steel |
| PAW-TA20C1E5STD | Tank 200L - Enamelled |
| PAW-TA30C1E5STD | Tank 300L - Enamelled |
| PAW-TD20B8E3-1 | Combo Tank 185L + 80L - Enamelled |
| PAW-TD23B6E5 | Combo Tank 230L + 60L - Stainless steel |

Accessories (optional)

| | |
|---------------------------|--|
| PAW-3WYVLV-HW | 3 way valve for DHW Tanks |
| PAW-BTANK50L-2 | Buffer tank 50L |
| CZ-TAW1 | Aquarea Smart Cloud for remote control and maintenance through wireless or wired LAN |
| PAW-A2W-RTWIRED | Room thermostat |
| PAW-A2W-RTWIRELESS | Wireless LCD room thermostat |

1) Sound power in accordance to 8112013,81312013 and EN12102-1:2017 at +7 °C. 2) WH-MDC models are hermetically sealed. EER and COP calculation is based in accordance to EN14511.



INTERNET CONTROL: Optional.

Aquarea T-CAP Mono-bloc H Generation Single Phase / Three Phase. Heating and Cooling - MXC

• R410A refrigerant



Technical focus

Optional Smartphone control — Maximum hydraulic module output temperature: 55 °C — Works at temperatures as low as -20 °C — Cooling temperature range 5 ~ 20 °C

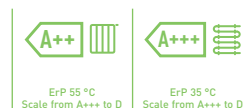

CZ-TAW1
Cloud connection.
For user control
and installer
remote
maintenance.

| | | Single Phase | | | Three Phase | |
|--|-----------------------|-----------------|--------------------|--------------------|----------------|----------------|
| Outdoor unit | | WH-MXC09H3E5 | WH-MXC12H6E5 | WH-MXC09H3E8 | WH-MXC12H9E8 | WH-MXC16H9E8 |
| Heating capacity / COP (A +7 °C, W 35 °C) | kW / COP | 9,00/4,84 | 12,00/4,74 | 9,00/4,84 | 12,00/4,74 | 16,00/4,28 |
| Heating capacity / COP (A +7 °C, W 55 °C) | kW / COP | 9,00/2,94 | 12,00/2,88 | 9,00/2,94 | 12,00/2,88 | 16,00/2,71 |
| Heating capacity / COP (A +2 °C, W 35 °C) | kW / COP | 9,00/3,59 | 12,00/3,44 | 9,00/3,59 | 12,00/3,44 | 16,00/3,10 |
| Heating capacity / COP (A +2 °C, W 55 °C) | kW / COP | 9,00/2,21 | 12,00/2,19 | 9,00/2,21 | 12,00/2,19 | 16,00/2,13 |
| Heating capacity / COP (A -7 °C, W 35 °C) | kW / COP | 9,00/2,85 | 12,00/2,72 | 9,00/2,85 | 12,00/2,72 | 16,00/2,49 |
| Heating capacity / COP (A -7 °C, W 55 °C) | kW / COP | 9,00/2,02 | 12,00/1,92 | 9,00/2,02 | 12,00/1,92 | 16,00/1,86 |
| Cooling capacity / EER (A 35 °C, W 7 °C) | kW / EER | 7,00/3,17 | 10,00/2,81 | 7,00/3,17 | 10,00/2,81 | 12,20/2,56 |
| Cooling capacity / EER (A 35 °C, W 18 °C) | kW / EER | 7,00/5,19 | 10,00/5,13 | 7,00/5,19 | 10,00/5,13 | 12,20/3,49 |
| Seasonal energy efficiency - Heating average climate (W35 °C / W55 °C) | ηs % | 181/130 | 170/130 | 181/130 | 170/130 | 160/125 |
| | SCOP | 4,60/3,33 | 4,33/3,33 | 4,60/3,33 | 4,33/3,33 | 4,08/3,20 |
| Energy class heating average climate (W35 °C / W55 °C) | | A+++ to D | A+++ to D | A+++ to D | A+++ to D | A+++ to D |
| Seasonal energy efficiency - Heating warm climate (W35 °C / W55 °C) | ηs % | 235/158 | 231/158 | 235/158 | 231/158 | 231/159 |
| | SCOP | 5,95/4,03 | 5,85/4,03 | 5,95/4,03 | 5,85/4,03 | 5,85/4,05 |
| Energy class heating warm climate (W35 °C / W55 °C) | | A+++ to D | A+++ to D | A+++ to D | A+++ to D | A+++ to D |
| Seasonal energy efficiency - Heating cold climate (W35 °C / W55 °C) | ηs % | 160/125 | 160/125 | 160/125 | 160/125 | 150/125 |
| | SCOP | 4,08/3,20 | 4,08/3,20 | 4,08/3,20 | 4,08/3,20 | 3,83/3,20 |
| Energy class heating cold climate (W35 °C / W55 °C) | | A+++ to D | A+++ to D | A+++ to D | A+++ to D | A+++ to D |
| Sound power part load ¹⁾ | Heat | 65 | 65 | 65 | 65 | 66 |
| Sound power full load | Heat / Cool | 68/67 | 69/68 | 68/67 | 69/68 | 72/71 |
| Dimension | HxWxD | mm | 1410x1283x320 | 1410x1283x320 | 1410x1283x320 | 1410x1283x320 |
| Net weight | | kg | 142 | 142 | 151 | 151 |
| Refrigerant (R410A) / CO ₂ Eq. ²⁾ | | kg / T | 2,30/4,802 | 2,30/4,802 | 2,30/4,802 | 2,30/4,802 |
| Water pipe connector | | Inch | R 1½ | R 1½ | R 1½ | R 1½ |
| Pump | Number of speeds | | Variable Speed | Variable Speed | Variable Speed | Variable Speed |
| | Input power (Min/Max) | W | 32/102 | 34/110 | 32/102 | 34/110 |
| Heating water flow (ΔT=5 K, 35 °C) | | L/min | 25,8 | 34,4 | 25,8 | 34,4 |
| Capacity of integrated electric heater | | kW | 3 | 6 | 3 | 9 |
| Input Power | Heat | kW | 1,86 | 2,53 | 1,86 | 2,53 |
| | Cool | kW | 2,21 | 3,56 | 2,21 | 3,56 |
| Running and Starting current | Heat | A | 8,8 | 11,7 | 3,0 | 4,0 |
| | Cool | A | 10,4 | 16,5 | 3,5 | 5,3 |
| Current 1 | | A | 29,0 | 29,0 | 14,7 | 11,9 |
| Current 2 | | A | 13,0 | 26,0 | 13,0 | 13,0 |
| Recommended fuse | | A | 30/30 | 30/30 | 16/16 | 16/16 |
| Recommended cable size, supply 1 / 2 | | mm ² | 3x4,0 or 6,0/3x4,0 | 3x4,0 or 6,0/3x4,0 | 5x1,5/3x1,5 | 5x1,5/5x1,5 |
| Operation range | Outdoor ambient | °C | -20 ~ +35 | -20 ~ +35 | -20 ~ +35 | -20 ~ +35 |
| | Water outlet | °C | 20 ~ 60 | 20 ~ 60 | 20 ~ 60 | 20 ~ 60 |
| Water outlet | Heat | °C | 20 ~ 60 | 20 ~ 60 | 20 ~ 60 | 20 ~ 60 |
| | Cool | °C | 5 ~ 20 | 5 ~ 20 | 5 ~ 20 | 5 ~ 20 |

Accessories (optional)

| | |
|------------------------|---|
| PAW-TD20C1E5 | Tank 200L - Stainless steel |
| PAW-TD30C1E5 | Tank 300L - Stainless steel |
| PAW-TA20C1E5STD | Tank 200L - Enamelled |
| PAW-TA30C1E5STD | Tank 300L - Enamelled |
| PAW-TD20B8E3-1 | Combo Tank 185L + 80L - Enamelled |
| PAW-TD23B6E5 | Combo Tank 230L + 60L - Stainless steel |

Accessories (optional)

| | |
|---------------------------|--|
| PAW-3WYVLV-HW | 3 way valve for DHW Tanks |
| PAW-BTANK50L-2 | Buffer tank 50L |
| CZ-TAW1 | Aquarea Smart Cloud for remote control and maintenance through wireless or wired LAN |
| PAW-A2W-RTWIRED | Room thermostat |
| PAW-A2W-RTWIRELESS | Wireless LCD room thermostat |

1) Sound power in accordance to 8112013,81312013 and EN12102-1:2017 at +7 °C. 2) WH-MXC models are hermetically sealed. EER and COP calculation is based in accordance to EN14511.



INTERNET CONTROL: Optional.

Aquarea HT Bi-bloc F Generation Single Phase / Three Phase. Heating Only - SHF • R407C refrigerant



Technical focus

Remote controller functions — Efficient control of room temperature based on the outdoor temperature, indoor temperature using the Aquarea Manager — Optional Smartphone control — Maximum hydraulic module output temperature: 65 °C — Works at temperatures as low as -20 °C — Maximum 20 m rise between the outdoor unit and the hydraulic module

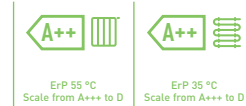

| Kit | Single Phase (Power to indoor) | | Three Phase (Power to indoor) | | |
|--|--------------------------------|---------------------|-------------------------------|--------------------------|--------------------------|
| | KIT-WHF09F3E5 | KIT-WHF12F6E5 | KIT-WHF09F3E8 | KIT-WHF12F9E8 | |
| Heating capacity / COP (A +7 °C, W 35 °C) | kW / COP | 9,00/4,64 | 12,00/4,46 | 9,00/4,64 | 12,00/4,46 |
| Heating capacity / COP (A +7 °C, W 65 °C) | kW / COP | 9,00/2,48 | 12,00/2,41 | 9,00/2,48 | 12,00/2,41 |
| Heating capacity / COP (A +2 °C, W 35 °C) | kW / COP | 9,00/3,45 | 12,00/3,26 | 9,00/3,45 | 12,00/3,26 |
| Heating capacity / COP (A +2 °C, W 65 °C) | kW / COP | 9,00/2,06 | 10,30/2,01 | 9,00/2,06 | 10,30/2,01 |
| Heating capacity / COP (A -7 °C, W 35 °C) | kW / COP | 9,00/2,74 | 12,00/2,52 | 9,00/2,74 | 12,00/2,52 |
| Heating capacity / COP (A -7 °C, W 65 °C) | kW / COP | 9,00/1,79 | 9,60/1,77 | 9,00/1,79 | 9,60/1,77 |
| Seasonal energy efficiency - Heating average climate (W35 °C / W55 °C) | ηs % | 153/125 | 150/125 | 153/125 | 150/125 |
| | SCOP | 3,90/3,20 | 3,83/3,20 | 3,90/3,20 | 3,83/3,20 |
| Energy class heating average climate (W35 °C / W55 °C) | A+++ to D | A++/A++ | A++/A++ | A++/A++ | A++/A++ |
| Seasonal energy efficiency - Heating warm climate (W35 °C / W55 °C) | ηs % | 191/156 | 188/156 | 191/156 | 188/156 |
| | SCOP | 4,85/3,98 | 4,78/3,98 | 4,85/3,98 | 4,78/3,98 |
| Energy class heating warm climate (W35 °C / W55 °C) | A+++ to D | A+++/A+++ | A+++/A+++ | A+++/A+++ | A+++/A+++ |
| Seasonal energy efficiency - Heating cold climate (W35 °C / W55 °C) | ηs % | 137/116 | 134/113 | 137/116 | 134/113 |
| | SCOP | 3,50/2,98 | 3,43/2,90 | 3,50/2,98 | 3,43/2,90 |
| Energy class heating cold climate (W35 °C / W55 °C) | A+++ to D | A+/A+ | A+/A+ | A+/A+ | A+/A+ |
| Indoor unit | | WH-SHF09F3E5 | WH-SHF12F6E5 | WH-SHF09F3E8 | WH-SHF12F9E8 |
| Sound pressure | dB(A) | 33 | 33 | 33 | 33 |
| Dimension | HxWxD | 892x502x353 | 892x502x353 | 892x502x353 | 892x502x353 |
| Net weight | | 46 | 47 | 47 | 48 |
| Water pipe connector | Inch | R 1¼ | R 1¼ | R 1¼ | R 1¼ |
| A class pump | Number of speeds | 7 | 7 | 7 | 7 |
| | Input power (Min/Max) | W | 38/100 | 40/106 | 38/100 |
| Heating water flow (ΔT=5 K, 35 °C) | L/min | 25,8 | 34,4 | 25,8 | 34,4 |
| Capacity of integrated electric heater | kW | 3 | 6 | 3 | 9 |
| Recommended fuse | A | 30/30 | 30/30 | 30/16 | 30/16 |
| Recommended cable size, supply 1 / 2 | mm | 3x4,0 or 6,0/3x4,0 | 3x4,0 or 6,0/3x4,0 | 5x1,5/3x1,5 | 5x1,5/5x1,5 |
| Outdoor unit | | WH-UH09FE5 | WH-UH12FE5 | WH-UH09FE8 | WH-UH12FE8 |
| Sound power part load ¹⁾ | dB(A) | — | — | — | — |
| Sound power full load | dB(A) | 66 | 67 | 66 | 67 |
| Dimension | HxWxD | 1340x900x320 | 1340x900x320 | 1340x900x320 | 1340x900x320 |
| Net weight | kg | 104 | 104 | 110 | 110 |
| Refrigerant (R407C) / CO ₂ Eq. | kg / T | 2,90/5,145 | 2,90/5,145 | 2,90/5,145 | 2,90/5,145 |
| Pipe diameter | Liquid / Gas | Inch (mm) | 3/8 (9,52) / 5/8 (15,88) | 3/8 (9,52) / 5/8 (15,88) | 3/8 (9,52) / 5/8 (15,88) |
| Pipe length range | m | 3-30 | 3-30 | 3-30 | 3-30 |
| Elevation difference (in/out) | m | 20 | 20 | 20 | 20 |
| Pipe length for additional gas | m | 10 | 10 | 10 | 10 |
| Additional gas amount | g/m | 70 | 70 | 70 | 70 |
| Operation range | Outdoor ambient | °C | -20 ~ +35 | -20 ~ +35 | -20 ~ +35 |
| Water outlet | Heat | °C | 25-65 | 25-65 | 25-65 |

Accessories (optional)

| | |
|------------------------|-----------------------------|
| PAW-TD20C1E5 | Tank 200L - Stainless steel |
| PAW-TD30C1E5 | Tank 300L - Stainless steel |
| PAW-TA20C1E5STD | Tank 200L - Enamelled |
| PAW-TA30C1E5STD | Tank 300L - Enamelled |

Accessories (optional)

| | |
|---------------------------|------------------------------|
| PAW-3WYVLV-HW | 3 way valve for DHW Tanks |
| PAW-BTANK50L-2 | Buffer tank 50L |
| PAW-A2W-RTWIRED | Room thermostat |
| PAW-A2W-RTWIRELESS | Wireless LCD room thermostat |

1) Sound power in accordance to 8112013,81312013 and EN11202-1:2017 at +7 °C. EER and COP calculation is based in accordance to EN14511.



INTERNET CONTROL: Optional.

Aquarea HT Mono-bloc G Generation Single Phase. Heating Only - MHF

- R407C refrigerant



Technical focus

Efficient control of room temperature based on the outdoor temperature, indoor temperature using the Aquarea Manager — Optional Smartphone control — Maximum hydraulic module output temperature: 65 °C — Works at temperatures as low as -20 °C

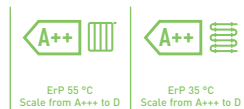

Single Phase

| Outdoor unit | | WH-MHF09G3E5 | WH-MHF12G6E5 |
|--|-----------------------|--------------------|--------------------|
| Heating capacity / COP (A +7 °C, W 35 °C) | kW / COP | 9,00/4,64 | 12,00/4,46 |
| Heating capacity / COP (A +7 °C, W 65 °C) | kW / COP | 9,00/2,48 | 12,00/2,41 |
| Heating capacity / COP (A +2 °C, W 35 °C) | kW / COP | 9,00/3,45 | 12,00/3,26 |
| Heating capacity / COP (A +2 °C, W 65 °C) | kW / COP | 9,00/2,06 | 10,30/2,01 |
| Heating capacity / COP (A -7 °C, W 35 °C) | kW / COP | 9,00/2,74 | 12,00/2,52 |
| Heating capacity / COP (A -7 °C, W 65 °C) | kW / COP | 9,00/1,79 | 9,60/1,77 |
| Seasonal energy efficiency - Heating average climate (W35 °C / W55 °C) | ηs % | 153/125 | 150/125 |
| | SCOP | 3,90/3,20 | 3,83/3,20 |
| Energy class heating average climate (W35 °C / W55 °C) | A+++ to D | A++/A++ | A++/A++ |
| Seasonal energy efficiency - Heating warm climate (W35 °C / W55 °C) | ηs % | 191/156 | 188/156 |
| | SCOP | 4,85/3,98 | 4,78/3,98 |
| Energy class heating warm climate (W35 °C / W55 °C) | A+++ to D | A+++/A+++ | A+++/A+++ |
| Seasonal energy efficiency - Heating cold climate (W35 °C / W55 °C) | ηs % | 137/116 | 134/113 |
| | SCOP | 3,50/2,98 | 3,43/2,90 |
| Energy class heating cold climate (W35 °C / W55 °C) | A+++ to D | A+/A+ | A+/A+ |
| Sound power part load ¹⁾ | dB(A) | — | — |
| Sound power full load | dB(A) | 68 | 69 |
| Dimension | HxWxD | 1410x1283x320 | 1410x1283x320 |
| Net weight | kg | 151 | 151 |
| Refrigerant (R407C) / CO ₂ Eq. ²⁾ | kg / T | 1,92/3,406 | 1,92/3,406 |
| Water pipe connector | Inch | R1½ | R1½ |
| Pump | Number of speeds | 7 | 7 |
| | Input power (Min/Max) | W | — |
| Heating water flow (ΔT=5 K. 35 °C) | L/min | 25,8 | 34,4 |
| Capacity of integrated electric heater | kW | 3 | 6 |
| Input Power | kW | 1,94 | 2,69 |
| Running and Starting current | A | 9,3 | 12,8 |
| Current 1 | A | 28,5 | 29,0 |
| Current 2 | A | 13,0 | 26,0 |
| Recommended fuse | A | 30/30 | 30/30 |
| Recommended cable size, supply 1 / 2 | mm ² | 3x4,0 or 6,0/3x4,0 | 3x4,0 or 6,0/3x4,0 |
| Operation range | Outdoor ambient | °C | -20 ~ +35 |
| Water outlet | Heat | °C | 25 ~ 65 |

Accessories (optional)

| | |
|-----------------|-----------------------------------|
| PAW-TD20C1E5 | Tank 200L - Stainless steel |
| PAW-TD30C1E5 | Tank 300L - Stainless steel |
| PAW-TA20C1E5STD | Tank 200L - Enamelled |
| PAW-TA30C1E5STD | Tank 300L - Enamelled |
| PAW-TD20B8E3-1 | Combo Tank 185L + 80L - Enamelled |

Accessories (optional)

| | |
|--------------------|---|
| PAW-TD23B6E5 | Combo Tank 230L + 60L - Stainless steel |
| PAW-3WYVLYV-HW | 3 way valve for DHW Tanks |
| PAW-BTANK50L-2 | Buffer tank 50L |
| PAW-A2W-RTWIRED | Room thermostat |
| PAW-A2W-RTWIRELESS | Wireless LCD room thermostat |

1) Sound power in accordance to 8112013,81312013 and EN12102-1:2017 at +7 °C. 2) WH-MHF models are hermetically sealed. EER and COP calculation is based in accordance to EN14511.



INTERNET CONTROL: Optional.

Smart fan coils

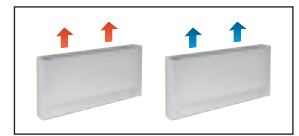

| Air flow | Speed | PAW-AAIR-200-2 | | | PAW-AAIR-700-2 | | | PAW-AAIR-900-2 | | |
|--------------------------------|---------------------|----------------|--------|--------|----------------|---------|---------|----------------|---------|---------|
| | | Min | Med | Max | Min | Med | Max | Min | Med | Max |
| Heating mode | | | | | | | | | | |
| Total heating capacity | W | 217,00 | 470,00 | 570,00 | 708,00 | 1032,00 | 1188,00 | 886,00 | 1420,00 | 1703,00 |
| Water flow | kg/h | 37,30 | 80,80 | 98,00 | 121,80 | 177,50 | 204,30 | 152,40 | 244,20 | 292,90 |
| Water pressure drop | kPa | 0,40 | 2,00 | 2,90 | 0,30 | 0,80 | 1,00 | 0,50 | 1,60 | 2,20 |
| Inlet water temperature | °C | 35 | 35 | 35 | 35 | 35 | 35 | 35 | 35 | 35 |
| Outlet water temperature | °C | 30 | 30 | 30 | 30 | 30 | 30 | 30 | 30 | 30 |
| Inlet air temperature | °C | 19,00 | 19,00 | 19,00 | 19,00 | 19,00 | 19,00 | 19,00 | 19,00 | 19,00 |
| Outlet air temperature | °C | 38,90 | 32,00 | 30,00 | 33,30 | 31,80 | 30,60 | 30,20 | 31,10 | 30,60 |
| Cooling mode | | | | | | | | | | |
| Total cooling capacity | W | 237,00 | 345,00 | 555,00 | 756,00 | 1039,00 | 1204,00 | 1153,00 | 1518,00 | 1746,00 |
| Sensible cooling capacity | W | 230,00 | 314,00 | 504,00 | 646,00 | 903,00 | 1058,00 | 1061,00 | 1384,00 | 1598,00 |
| Water flow | kg/h | 40,00 | 59,00 | 95,00 | 129,00 | 178,00 | 207,00 | 198,00 | 261,00 | 300,00 |
| Water pressure drop | kPa | 0,40 | 2,00 | 2,90 | 1,00 | 2,00 | 2,00 | 6,00 | 9,00 | 12,00 |
| Inlet water temperature | °C | 10 | 10 | 10 | 10 | 10 | 10 | 10 | 10 | 10 |
| Outlet water temperature | °C | 15 | 15 | 15 | 15 | 15 | 15 | 15 | 15 | 15 |
| Inlet air temperature | °C | 27,00 | 27,00 | 27,00 | 27,00 | 27,00 | 27,00 | 27,00 | 27,00 | 27,00 |
| Outlet air temperature | °C | 15,00 | 17,00 | 18,00 | 14,00 | 16,00 | 17,00 | 16,00 | 17,00 | 18,00 |
| Relative humidity of inlet air | % | 47 | 47 | 47 | 47 | 47 | 47 | 47 | 47 | 47 |
| Air flow | m ³ /min | 0,90 | 1,90 | 2,70 | 2,60 | 4,20 | 5,30 | 4,10 | 6,10 | 7,70 |
| Maximum input power | W | 7,00 | 9,00 | 13,00 | 14,00 | 18,00 | 22,00 | 16,00 | 20,00 | 24,00 |
| Sound pressure | dB(A) | 23 | 33 | 40 | 24 | 36 | 42 | 25 | 36 | 44 |
| Dimension (HxWxD) | mm | 735x579x129 | | | 935x579x129 | | | 1135x579x129 | | |
| Net weight | kg | 17 | | | 20 | | | 23 | | |
| 3 Ways valve included | | Yes | | | Yes | | | Yes | | |
| Touch screen thermostat | | Yes | | | Yes | | | Yes | | |

* Smart fan coils is produced by Innova.

Accessories (optional)

PAW-AAIR-LEGS-1 Kits of 2 legs to support the Smart fan coil on the floor and to protect the water pipings

Accessories (optional)

PAW-AAIR-RHCABLE Motor connection cable for units with hydraulic connections on the right

Stylish Floor-standing fan coils with advanced controller

The slimline of Smart fan coils delivers high efficiency climate control.

With a depth of just under 13cm they are at the cutting edge of the market. Blending easily into the home, Smart fan coil's elegant design and product refinements are clear to see in every detail.

Exceptional ventilation efficiency means the motor uses considerably less energy (low wattage). The fan speed is continuously modulated by the temperature controller with proportional integral logic, with undoubted advantages for regulating the temperature and humidity in summer mode.

With standard cast radiators.

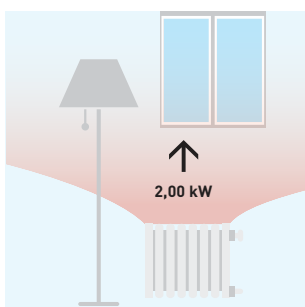

With Smart fan coil.

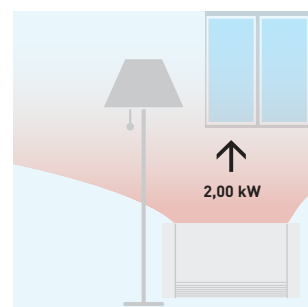

Water at 65 °C needed.

Water at 35 °C needed.



Technical focus:

- High heating capacity
- 3 fan speeds and capacities
- Exclusive design
- Extremely compact (only 12,9cm deep)
- Cooling and dehumidification functions possible (drain is needed)
- 3-way valve included (no overflow valve needed on the installation if more than 3 units installed)
- Touch screen thermostat

All temperature curves and capacity are available on www.panasonicproclub.com

Fan coils

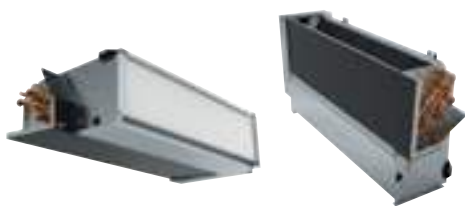

PAW-FC-903TC
Optional Controller.
Wired remote controller.



PAW-FC-RC1
Optional Controller.
Advanced wired remote controller.

| Compact units | | | | | | | | | | High Static Pressure | |
|---|---------------|-------------------|----------------|----------------|----------------|----------------|----------------|----------------|----------------|----------------------|---------------|
| Left side connection | | | PAW-FC-D11-1 | PAW-FC-D15-1 | PAW-FC-D24-1 | PAW-FC-D28-1 | PAW-FC-D40-1 | PAW-FC-D55-1 | PAW-FC-D65-1 | PAW-FC-D90-1 | PAW-FC-H150 |
| Right side connection | | | PAW-FC-D11-1-R | PAW-FC-D15-1-R | PAW-FC-D24-1-R | PAW-FC-D28-1-R | PAW-FC-D40-1-R | PAW-FC-D55-1-R | PAW-FC-D65-1-R | PAW-FC-D90-1-R | PAW-FC-H150-R |
| Total cooling capacity ¹⁾ | Med/S-Hi | kW | 1,0/1,5 | 1,2/1,7 | 2,0/2,5 | 2,4/3,2 | 3,2/4,6 | 4,6/5,8 | 6,1/7,3 | 6,1/8,1 | 11,9/14,8 |
| Sensible cooling capacity ¹⁾ | Med/S-Hi | kW | 0,8/1,1 | 0,9/1,3 | 1,5/1,9 | 1,8/2,3 | 2,2/3,3 | 3,3/4,5 | 4,3/5,1 | 4,6/6,3 | 9,6/12,9 |
| Heating capacity ¹⁾ | Med/S-Hi | kW | 1,4/2,0 | 1,5/2,2 | 2,4/3,1 | 2,9/4,0 | 4,1/5,7 | 5,3/7,1 | 7,9/9,3 | 8,1/11,6 | 14,9/19,9 |
| Power consumption | S-Lo/Med/S-Hi | W | 13/24/36 | 10/18/29 | 16/37/45 | 15/37/56 | 28/55/72 | 37/75/105 | 53/100/147 | 90/112/188 | 180/421/675 |
| Fuse rating | | A | 2 | 2 | 2 | 2 | 2 | 2 | 2 | 2 | 6 |
| Dimensions ²⁾ | H x W x D | mm | 220x570x430 | 220x570x430 | 220x753x430 | 220x938x430 | 220x1122x430 | 220x1307x430 | 220x1121x530 | 220x1316x530 | 376x1600x798 |
| Weight ³⁾ | | kg | 13 | 13 | 15 | 20 | 22 | 26 | 27 | 38 | 63 |
| Sound power global | S-Lo/Med/S-Hi | dB(A) | 33/40/49 | 31/43/50 | 30/45/52 | 30/44/51 | 34/46/56 | 38/51/58 | 43/56/61 | 50/55/64 | 52/64/71 |
| Sound pressure global | S-Lo/Med/S-Hi | dB(A) | 24/31/40 | 22/34/41 | 21/36/43 | 21/35/42 | 25/37/47 | 29/42/49 | 34/47/52 | 41/46/55 | 31/45/51 |
| Static pressure Max | | Pa | 30 | 30 | 50 | 50 | 70 | 70 | 70 | 70 | 110 |
| Airflow ¹⁾ | Med/S-Hi | m ³ /h | 190/283 | 179/265 | 274/390 | 357/499 | 486/716 | 640/933 | 893/1064 | 936/1397 | 2112/3176 |
| Water pressure drop | Med/S-Hi | kPa | 19,5/39,2 | 3,9/6,3 | 19,3/28,8 | 17,1/28 | 22,8/46,9 | 37,4/60,2 | 15,4/21,5 | 19,3/32,5 | 19,8/26,1 |
| Fan speeds | | | 3 speeds | 3 speeds | 3 speeds | 3 speeds | 3 speeds | 3 speeds | 3 speeds | 3 speeds | 3 speeds |
| Fan motor and number of speeds | | | AC 5 speeds | AC 5 speeds | AC 5 speeds | AC 5 speeds | AC 5 speeds | AC 5 speeds | AC 5 speeds | AC 5 speeds | AC 5 speeds |
| Drain pan and air filter | | | Included | Included | Included | Included | Included | Included | Included | Included | Included |
| Water connections | | Inch | 1/2 | 1/2 | 1/2 | 1/2 | 1/2 | 1/2 | 3/4 | 3/4 | 1 |

Accessories (optional)

| | |
|---------------------------|---|
| PAW-FC-RC1 | Advanced wired remote controller for fan coil |
| PAW-FC-903TC | NEW Wired remote controller for fan coil |
| PAW-FC-2WY-11/55-1 | 2 way valve + drain pan (for PAW-FC-D11/15/24/28/40/55-1) |
| PAW-FC-2WY-65/90-1 | 2 way valve + drain pan (for PAW-FC-D65/90-1) |

Accessories (optional)

| | |
|---------------------------|---|
| PAW-FC-2WY-150 | 2 way valve (for PAW-FC-H150) |
| PAW-FC-3WY-11/55-1 | 3 way valve + drain pan (for PAW-FC-D11/15/24/28/40/55-1) |
| PAW-FC-3WY-65/90-1 | 3 way valve + drain pan (for PAW-FC-D65/90-1) |
| PAW-FC-3WY-150 | 3 way valve (for PAW-FC-H150) |

1) Airflow and capacity at 0 Pa of static pressure. 2) Including pan and electrical box. 3) Without water content. * Performances based on: Cooling: Air: 27 °C DB / 19 °C WB, Chilled water: 7 °C / 12 °C - Heating: Air: 20 °C DB, Hot water: 50 °C / 45 °C. ** Fan coil units are produced by Systemair.



Range of fan coil units

This advanced controller provides a higher level and performance. The fan coil range consists of a compact ducted range ideal for residential and commercial use and one model with high static pressure for commercial applications. All units are certified by Eurovent, include drain pan and filter and are equipped with a low consumption fan motor.

The D type is even more flexible thanks to an L-shaped drain pan. The unit can be installed either in a horizontal or in a vertical position.

Fan coil controller PAW-FC-RC1

This advanced controller provides a higher level of comfort in heating. The sensor can be used as a water flow sensor, stopping the fan when the water temperature is low, avoiding cold drafts in winter.

Also is ready to use J Generation feature of defrost mode and stop the fan coil.

Features:

- Room thermostat
- 3 outputs, 230 V relays for fan control
- 2 outputs, 230 V relays for heating / cooling control
- Modbus RTU slave
- 1 DI for presence detection (key card switch)
- 1 AI for sensor

1 Innovation for an optimum comfort

3 Efficient high-quality coil

2 Low energy consumption fan

4 Flexible installation: vertical or horizontal

Sanitary Tanks

Combo Tank.

The best option to combine with Mono-bloc units. DHW tank with buffer tank. Designed for retrofit applications, the DHW tank with a buffer tank is particularly suitable for fast integration on an existing installation. This tank includes a 3-way valve and an "A" Class pump. Easy to install, nice looking, high efficiency for DHW production and for heating.

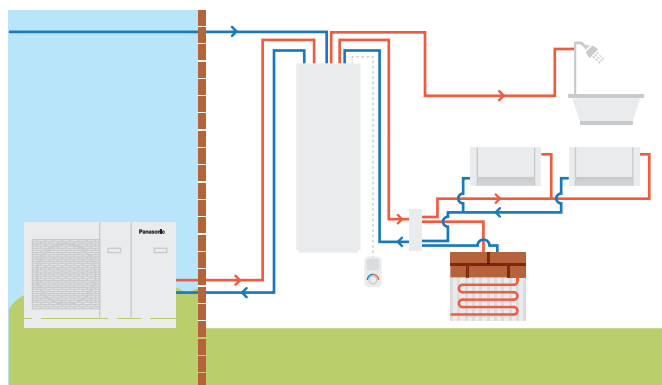

| | | Enamelled | | NEW Stainless steel | |
|---|----------------|--------------------|-------------|---------------------|-------------|
| Model | | PAW-TD20B8E3-1 | | PAW-TD23B6E5 | |
| Dimension H x W x D | mm | 1770 x 640 x 690 | | 1750 x 600 x 646 | |
| Weight (empty) | kg | 150 | | 111 | |
| Volume | L | 185 + 80 | | 230 + 60 | |
| Power supply | V, Phase, Hz | 230, 1, 50 | | 230, 1, 50 | |
| | | Hot water tank | Buffer tank | Hot water tank | Buffer tank |
| Volume | L | 185 | 80 | 230 | 60 |
| Max working pressure | MPa (bar) | 0,8 (8) | 0,6 (6) | 1,0 (10) | 0,3 (3,0) |
| Pressure test | MPa (bar) | 1,2 (12) | 0,9 (9) | 1,5 (15) | 0,39 (3,9) |
| Max working temp | °C | 90 | 90 | 80 | 80 |
| Connections | mm | Ø22 | Ø22 | Ø22 | Ø22, copper |
| Material | | S 275 JR vitrified | S235 JR | EN 14521 | EN 14521 |
| Insulation | Material, t=mm | PUR, 50 | PUR 40 mm | PUR, 50 | PUR, 50 |
| Heating coil surface | m ² | 2,1 | — | 1,8 | — |
| Electrical heater | W | 3000 | — | 2800 | — |
| Energy loss at 65 °C | kWh/24h | 1,3 | — | 1,25 | — |
| Energy efficiency class (from A+ to F) | | B | B | B | A |
| Standing loss | W | 53 | 46 | 52 | 29 |

1) EU Regulation 812/2013. 2) Tested pursuant to EN 12897:2006. * Enamelled Combo Tank is produced by Lapesa. Stainless Steel Combo Tank is produced by OSO.





Enamelled Tanks.

| Model | Enamelled Tank | | | | Enamelled 2 coils Tank (for bivalent Solar + HP) | NEW Square Tank |
|---|-----------------|-----------------|-----------------|-----------------|--|----------------------|
| | PAW-TA15C1E5STD | PAW-TA20C1E5STD | PAW-TA30C1E5STD | PAW-TA40C1E5STD | PAW-TA30C2E5STD | PAW-TA20C1E5C |
| Water volume | L | 150 | 200 | 290 | 380 | 200 |
| Maximum water temperature | °C | 95 | 95 | 95 | 95 | 95 |
| Dimensions (Hight / Diameter) | mm | 1210/520 | 1340/610 | 1800/610 | 1835/670 | 1550 x 600 x 600 |
| Weight / filled with water | kg | 109/254 | 90/280 | 120/389 | 191/572 | 134 / 327 |
| Electric heater | kW | — | 3,00 | 3,00 | 3,00 | — |
| Power supply | V | — | 230 | 230 | 230 | — |
| Material inside tank | | Enamelled | Enamelled | Enamelled | Enamelled | Enamelled |
| Exchange surface | m ² | 1,2 | 1,8 | 2,6 | 3,8 | 1,83 |
| Energy loss at 65 °C ¹⁾ | kWh/24h | 1,45 | 1,37 | 1,61 | 1,76 | 1,37 |
| 3 way valve accessory PAW-3WYVLV-HW or CZ-NV1 | | Optional | Optional | Optional | Optional | Built-in 3 way valve |
| 20 m temperature sensor cable included | | Yes | Yes | Yes | Yes | Yes |
| Energy losses | W | 60 | 57 | 67 | 73 | 57 |
| Energy Efficiency Class (from A+ to F) | | C | B | B | B | B |
| Warranty | | 2 Years | 2 Years | 2 Years | 2 Years | 2 Years |
| Maintenance required | | Every 2 years | Every 2 years | Every 2 years | Every 2 years | Every 2 years |

1) Insulated tested under EN12897. ** Enamelled Tanks are produced by AEmail.



Stainless Steel Tank.

| Model | | PAW-TD20C1E5 | PAW-TD30C1E5 |
|---|----------------|-----------------|-----------------|
| Water volume | L | 192 | 280 |
| Maximum water temperature | °C | 75 | 75 |
| Dimensions (Hight / Diameter) | mm | 1270/595 | 1750/595 |
| Weight / filled with water | kg | 53/— | 65/— |
| Electric heater | kW | 1,50 | 1,50 |
| Power supply | V | 230 | 230 |
| Material inside tank | | Stainless steel | Stainless steel |
| Exchange surface | m ² | 1,8 | 1,8 |
| Energy loss at 65 °C ¹⁾ | kWh/24h | 0,99 | 1,13 |
| 3 way valve accessory PAW-3WYVLV-HW or CZ-NV1 | | Optional | Optional |
| 20 m temperature sensor cable included | | Yes | Yes |
| Energy losses | W | 42 | 46 |
| Energy Efficiency Class (from A+ to F) | | A | A |
| Warranty | | 2 Years | 2 Years |
| Maintenance required | | No | No |

1) Insulated tested under EN12897. ** Stainless Steel Tanks and Buffer Tank are produced by OSO.

New Buffer tank.

| Model | | PAW-BTANK50L-2 |
|---|----|-----------------|
| Capacity | L | 48 |
| Energy losses | W | 42 |
| Energy Efficiency Class (from A+ to F) | | B |
| Material | | Stainless Steel |
| Dimensions (Hight / Diameter) | mm | 636 / 430 |
| Net weight | kg | — |

* Automatic air vent and drain cock are included. Built-in pocket sensor (sensor not included).

Accessories for Sanitary tanks

| | |
|----------------------|---|
| PAW-3WYVLV-HW | 3 way valve for DHW Tanks |
| CZ-NV1 | 3 way valve kit for inside the hydrokit |

Heat Recovery Ventilation unit



1 Comfort
High thermal comfort.

2 Energy saving
Lower heating requirements thanks to lower heat losses.

3 Space saving
It can be installed over the DHW square tank or the All-in-one Compact indoor unit.

4 Better user interface
Possibility to control the ventilation unit and the heating system with one single remote controller.

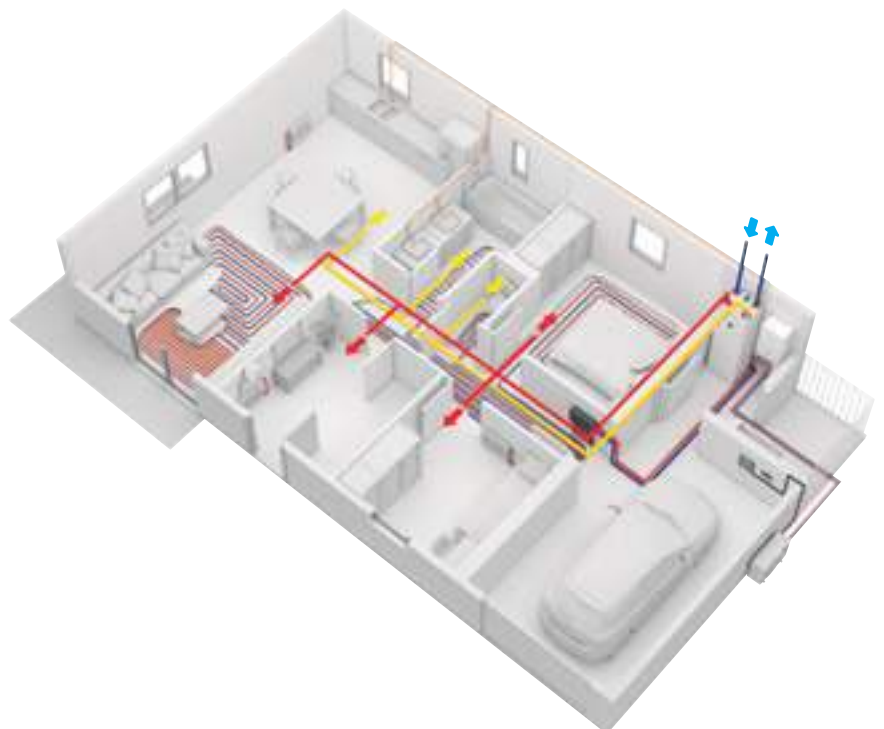

Ventilation systems with heat recovery offer users a high degree of living comfort thanks to temperature controlled and clean air. Heat recovery units are ideal for use in houses, for these owners who are looking for high performance and maximum comfort.

| Heat Recovery Ventilation unit | | PAW-A2W-VENTA-R | PAW-A2W-VENTA-L |
|--|-------------------|------------------------------|-----------------|
| Nominal airflow rate | m ³ /h | 204 @ 50 Pa | |
| Maximum airflow rate | m ³ /h | 292 @ 100 Pa | |
| SPF | | 1,24 @ 204 m ³ /h | |
| Heat exchanger rotor drive type | | Variable speed | |
| Exchanger type | | Rotating | |
| Heat recovery efficiency | | 84 % | |
| Power supply | V / Hz | 230 / 50 / 1 phase | |
| Power consumption | W | 176 | |
| Energy Class, basic unit | | A | |
| Energy Class, unit with local control on demand | | A | |
| Noise level | dB | 38 | |
| Dimensions (W x H x D) | mm | 598 x 450 x 500 | |
| Weight | kg | 46 | |
| Mounting position | | Vertical | |
| Supply side | | Right | Left |
| Duct connections | mm | DN125 | |
| Filter class, supply air | | F7/ePM1 60 % | |
| Filter class, extract air | | M5/ePM10 50 % | |
| Minimum outdoor temperature | °C | -20 | |

| Accessories (optional) | |
|-------------------------|---|
| PAW-VEN-FLTKIT | Supply and extract filters kit |
| PAW-VEN-ACCPCB | Optional PCB for additional functions |
| PAW-VEN-DPL | HRV touch control panel. White frame (cable must be ordered separately) |
| PAW-VEN-CBLEXT12 | Cable with plug for electrical connection between unit and control panel, type CE and CD (12 m) |
| PAW-VEN-DIVPLG | Twin plugs for installation of several control panels type CD or CE for one unit |

| Accessories (optional) | |
|--------------------------|---|
| PAW-VEN-DPLBOX | HRV touch control panel wall-mounted kit |
| PAW-VEN-S-CO2RH-W | CO ₂ RH wall-mounted sensor |
| PAW-VEN-S-CO2-W | CO ₂ wall-mounted sensor |
| PAW-VEN-S-CO2-D | CO ₂ duct sensor |
| PAW-VEN-PTC12 | 1,2 kW PTC heater DN125 |
| PAW-VEN-PTC08 | 0,8 kW PTC heater DN125 |
| PAW-VEN-WBRK | Wall bracket kit for stand-alone installation on the wall |

* Heat recovery efficiency according to EN 13141-7. ** Heat Recovery Ventilation unit is produced by RVU & square tank by AEmail.

With an optimum exchange program, the ventilation unit guides air extracted from the kitchen and bathroom to the outside. Fresh outdoor air is drawn into the unit via the pipe system. Here 84 % of the heat from the extract air is transferred to the supply air via a heat exchanger, which is then supplied back to the living and sleeping quarters.

Main features:

- Heat recovery unit designed for ventilated areas up to approximately 140 m².
- High energy-efficiency rotary heat exchanger with EC - technology fans
- Moisture transfer function to minimize condensation in supply air during wintertime
- Control via touch display and Startup Wizard for easy commissioning

- Modbus communication via RS-485
- Option to control Aquarea H and J series heat pumps from PAW-A2W-VENTA control panel if both units are connected via Modbus interface (PAW-AW-MBS-H and PAW-VEN-ACCPCB required)

The built in humidity sensor in extract air can be used for demand control.

Control

- All settings and features accessible via a control panel, integrated into the front cover.
- Color touch screen with a user-friendly interface
 - The option for connecting one or more external control panels is available
 - Separate user level for authorized installers and service personnel

- MANUAL and AUTO mode or choose preferred settings from the pre-configured user modes
- If Aquarea H and J series heat pumps are connected with PAW-A2W-VENTA, the heat pump control options will appear on the home screen in a separate tab

The unit can be mounted on a PAW-TA20C1E5C, on a WH-ADC0309J3E5C or installed on the wall (PAW-VEN-WBRK is needed).

DHW Stand Alone



New DHW Stand Alone: highly efficient heat pump water heater.

The wide range of DHW Stand Alone heat pump is a great solution to adapt to any type of family house. The wall type is available in 100 and 150L capacities, and the Floor-standing in 200 and 270L. For reaching even more efficient use the 270L is available in additional coil, it is able to connect solar water production.

- A+ Highly efficient domestic hot water heat pump
- Provides reduced power consumption by 75 % compared with traditional electric water heater
- Easy to install
- Being CFC-free, this water heater is environmentally friendly

1 Energy saving

- Digital control panel with energy consumption monitoring
- Photovoltaic function
- Compatible with ducted fresh air intake installations
- Boiler/Solar Coil (only PAW-DHW270C1F)

2 Comfort

- Different modes of operation based on user needs
- Mode AUTO: Intelligent Temperature Set Point, thanks to monitoring hot water usage
- Mode BOOST, Mode ECO and Mode ABSENCE

3 Durability

- Diamond-quality enamel lining the inner tank
- Pressure relief valve which provides safety if any malfunctions or pressure rise
- Dielectric union preventing corrosion
- Specific lip gasket preventing rust around the flange

| Model | Wall-mounted | | | Floor-standing | |
|--|----------------------|-----------------------------------|------------------|--|------------------|
| | PAW-DHW100W-1 | PAW-DHW150W-1 | PAW-DHW200F | PAW-DHW270F | PAW-DHW270C1F |
| Reference | | | | | |
| Nominal capacity | L | 100 | 150 | 200 | 270 |
| Dimensions (H x W x D) | mm | 1209 x 522 x 538 | 1527 x 522 x 538 | 1617 x 620 x 665 | 1957 x 620 x 665 |
| Empty weight | kg | 57 | 66 | 80 | 92 |
| Hot and cold connection | | ¾" M | ¾" M | ¾" M | ¾" M |
| Anticorrosion system | Anode | Magnesium | Magnesium | Magnesium | Magnesium |
| Rated water pressure | Mpa (bar) | 0,8 (8) | 0,8 (8) | 0,8 (8) | 0,8 (8) |
| Electrical connection | V / Hz | 230/50 | 230/50 | 230/50 | 230/50 |
| Total maximum power | W | 1550 | 1950 | 2300 | 2300 |
| Maximal power heat pump | W | 350 | 350 | 700 | 700 |
| Power electric heating element | W | 1200 | 1600 | 1600 | 1600 |
| Heat pump water temperature range | °C | 50 – 62 | 50 – 62 | 50 – 62 | 50 – 62 |
| Heat pump air temperature range | °C | -5 – +43 | -5 – +43 | -5 – +43 | -5 – +43 |
| Duct diameter | mm | 125 | 125 | 160 | 160 |
| Air flow (without duct) | m³/h | 160 | 160 | 310/390 | 310/390 |
| Load losses acceptable on ventilation circuit, without affecting performance | Pa | 70 | 70 | 25 | 25 |
| Sound power level ¹⁾ | dB(A) | 45 | 45 | 53 | 53 |
| R134a refrigerant capacity | kg | 0,52 | 0,58 | 0,80 | 0,86 |
| Refrigerant volume in tons of CO ₂ equivalent | TCO ₂ Eq. | 0,74 | 0,83 | 0,50 | 0,54 |
| Refrigerant weight per liter | kg/L | 0,0052 | 0,0039 | 0,0040 | 0,0032 |
| Hot water quantity at 40 °C: V40td | L | 151,0 | 182,0 | 265,5 | 361,2 |
| Acoustic power ErP ²⁾ | dB(A) | 45 | 45 | 53 | 53 |
| Energy Efficiency Class (from A+ to F) | | A+ | A+ | A+ | A+ |
| Connectable to PV | | Yes | Yes | Yes | Yes |
| Additional coil exchanger connection | | — | — | — | — |
| Additional coil surface | m² | — | — | — | 1,2 |
| Performance at 7 °C air temperature | | (EN 16147) ducted at 25 Pa | | (CDC LCIE 103-15/C) ducted at 30 Pa ³⁾ | |
| Coefficient of performance (COP) according load profile | | 2,47 - M | 3,05 - L | 2,79 - L | 3,16 - XL |
| Standby power input (P _{es}) | W | 18 | 24 | 32 | 29 |
| Heating up time (t _h) | h. Min | 6h47 | 10h25 | 07h11 | 10h39 |
| Reference hot water temperature (T _{ref}) | °C | 52,7 | 53,2 | 52,7 | 53,1 |
| Flow rate (air) | m³/h | 140 | 110 | 320 | 320 |
| Performance at 15 °C air temperature (EN 16147) | | | | | |
| Coefficient of performance (COP) according load profile | | 2,88 - M | 3,28 - L | 3,05 - L | 3,61 - XL |
| Standby power input (P _{es}) | W | 19 | 25 | 30 | 30 |
| Heating up time (t _h) | h. Min | 6h07 | 9h29 | 6h24 | 8h34 |
| Reference hot water temperature (T _{ref}) | °C | 52,6 | 53,4 | 52,8 | 53,0 |
| Flow rate (air) | m³/h | 140 | 110 | 320 | 320 |

Accessories (optional)

PAW-DHW-STAND Rack for suspended device for 100 and 150 liters models

1) According to ISO3744. 2) Compliant with EN 16147 conditions. 3) Performance measured for a water heater from 10 °C to T_{ref} according to the protocol of the NF Electricity Performance Mark specifications No.LCIE 103-15C, selfheating thermodynamic water heaters (based on standard EN 16147). * DHW Stand Alone is produced by S.A.T.E.

Ideal for small surfaces

Suitable for all installations (adapted to small surfaces, low ceiling, corner).

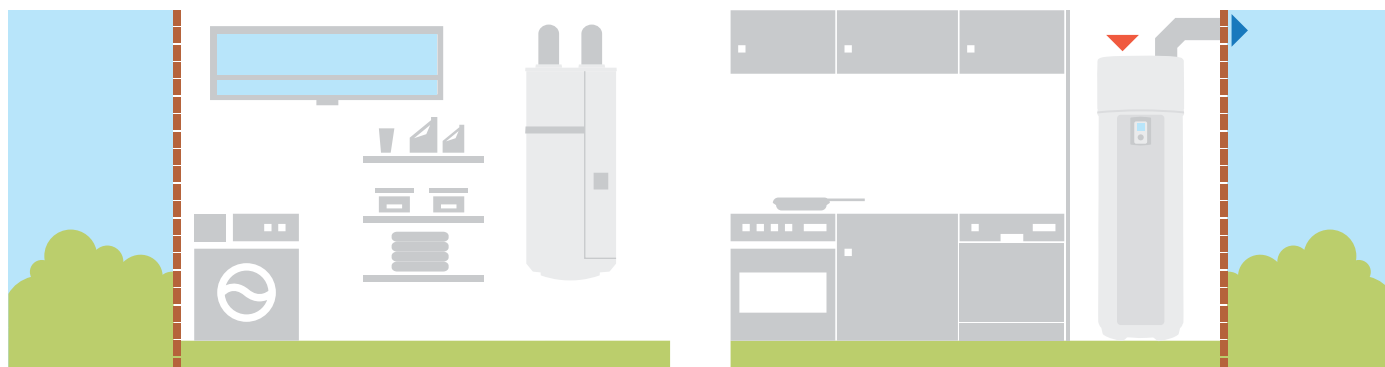

Accessories and Control

All in One accessories

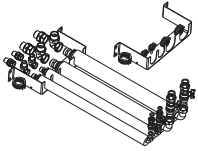

PAW-ADC-PREKIT-H
Flexible pipings and wall mounting plate for All in One H Generation.

PAW-ADC-PREKIT-1
Flexible pipings and wall mounting plate for All in One J Generation (not compatible with WH-ADC0309J3E5C).



PAW-ADC-CV150
Decorative magnetic side cover.

Special outdoor supports

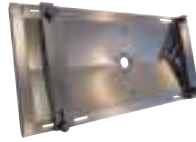

PAW-WTRAY
Tray for condenser water compatible with base ground support.



PAW-GRDSTD40
Outdoor elevation platform.



PAW-GRDBSE20
Outdoor base ground support for noise and vibration absorption (600 x 95 x 130 mm, 500kg).

PCB's for additional functions



CZ-NS4P
PCB for advanced functions in J and H Generation.

Deice accessories



CZ-NE1P
Base pan heater (for all old Bi-bloc and Mono-bloc, not for the 3 and 5 kW).

CZ-NE2P
Base pan heater (for Bi-bloc 3 kW and 5 kW).

CZ-NE3P
Base pan heater for J and H Generation.

Hydraulic accessories



CZ-NV1
3 way valve kit for inside the hydrokit.



PAW-3WYVLV-HW
3 way valve for DHW Tanks.

PAW-A2W-AFVLV
Anti-freeze valve.

Smart fan coil accessories

PAW-AAIR-LEGS-1
Kits of 2 legs to support the Smart fan coil on the floor and to protect the water pipings.

PAW-AAIR-RHCABLE
Motor connection cable for units with hydraulic connections on the right.

Fan coil accessories



PAW-FC-903TC
NEW Wired remote controller for fan coil.



PAW-FC-RC1
Advanced wired remote controller for fan coil.

PAW-FC-2WY-11/55-1
2 way valve + drain pan (for PAW-FC-D11/15/24/28/40/55-1).

PAW-FC-2WY-65/90-1
2 way valve + drain pan (for PAW-FC-D65/90-1).

PAW-FC-2WY-150
2 way valve (for PAW-FC-H150).

PAW-FC-3WY-11/55-1
3 way valve + drain pan (for PAW-FC-D11/15/24/28/40/55-1).

PAW-FC-3WY-65/90-1
3 way valve + drain pan (for PAW-FC-D65/90-1).

PAW-FC-3WY-150
3 way valve (for PAW-FC-H150).

Sanitary tank accessories



PAW-TS1
Tank sensor with 6 m cable length.

PAW-TS2
Tank sensor with 20 m cable length.

PAW-TS4
Tank sensor with 6 m cable length and only 6 mm diameter.



CZ-TK1
Temperature sensor kit for third party tank (with copper pocket and 6 m length sensor cable).



PAW-VEN-DPL
HRV touch control panel. White frame (cable must be ordered separately).



PAW-VEN-S-CO2RH-W
CO₂ RH wall-mounted sensor.

PAW-VEN-S-CO2-W
CO₂ wall-mounted sensor.



PAW-VEN-CBLEXT12
Cable with plug for electrical connection between unit and control panel, type CE and CD (12 m).



PAW-VEN-S-CO2-D
CO₂ duct sensor.



PAW-VEN-DIVPLG
Twin plugs for installation of several control panels type CD or CE for one unit.

PAW-VEN-FLTKit
Supply and extract filters kit.

PAW-VEN-ACCPCB
Optional PCB for additional functions.



PAW-VEN-DPLBOX
HRV touch control panel wall-mounted kit.

PAW-VEN-PTC12
1,2 kW PTC heater DN125.

PAW-VEN-PTC08
0,8 kW PTC heater DN125.

PAW-VEN-WBRK
Wall bracket kit for stand-alone installation on the wall.

DHW Stand Alone accessories



PAW-DHW-STAND
Rack for suspended device for 100 and 150 liters models.

Connectivity solutions



CZ-TAW1
Aquearea Smart Cloud for remote control and maintenance through wireless or wired LAN.



PAW-AW-KNX-1i
KNX Interface compatible with G and F Generation.



PAW-AW-MBS-1
Modbus interface compatible with G and F Generation.

CZ-TAW1-CBL
10 m extension cable for CZ-TAW1.

PAW-AW-KNX-H
KNX Interface for J and H Generation.

PAW-AW-MBS-H
Modbus Interface for J and H Generation.

Cascade Controller



PAW-A2W-CMH
Modbus IP for BMS communication.

Room thermostats



PAW-A2W-RTWIRED
Wired LCD room thermostat with weekly timer.



PAW-A2W-RTWIRELESS
Wireless LCD room thermostat with weekly timer.

H Generation sensors



PAW-A2W-TSOD
Outdoor ambient sensor.



PAW-A2W-TSRT
Zone room sensor.



PAW-A2W-TSHC
Zone water sensor.



PAW-A2W-TSSO
Solar sensor.



PAW-A2W-TSBU
Buffer tank sensor.

Aquearea Manager accessories (not compatible with J and H Generation)



PAW-HPM1
Aquearea Manager with LCD.



PAW-HPM2
Aquearea Manager without LCD.



PAW-HPMED
Touch screen.



PAW-HPMB1
Buffer tank sensor.



PAW-HPMAH1
Water flow pipe sensor for heating circuit.



PAW-HPMUH
Outdoor temperature sensor.

PAW-HPMINT-U
Interface to connect Aquearea Manager to Heat pump Aquearea Bi-bloc (HPM can control all parameters from HP).

PAW-HPMINT-M
Interface to connect Aquearea Manager to Heat pump Aquearea Mono-bloc (HPM can control all parameters from HP).

PAW-HPMINT-F
Interface to connect Aquearea Manager to Heat pump Aquearea Mono-bloc and Bi-bloc F type (HPM can control all parameters from HP).

PAW-HPMDHW
Buffer tank sensor with well.

PAW-HPMSOL1
Buffer tank sensor solar (with higher temperature range).

PAW-HPMR4
Room sensor + set point adaptation.

PAW-DEWPOINTSENSOR
Dew point sensor.

Heating & Cooling capacity tables

Based on outlet temperature and outside temperature.

Aquarea High Performance Bi-bloc J Generation Single Phase. Heating and Cooling • R32 refrigerant

WH-UD03JE5

| Tamb | HC | IP | COP | HC | IP | COP | HC | IP | COP | HC | IP | COP | HC | IP | COP |
|------|------|------|-------|------|------|------|------|------|------|------|------|------|------|------|------|
| LWC | 25 | 25 | 25 | 35 | 35 | 35 | 45 | 45 | 45 | 55 | 55 | 55 | 60 | 60 | 60 |
| -20 | 2,50 | 1,11 | 2,25 | 2,52 | 1,31 | 1,92 | 2,24 | 1,59 | 1,41 | 2,12 | 1,80 | 1,18 | — | — | — |
| -15 | 3,00 | 1,14 | 2,63 | 3,20 | 1,37 | 2,34 | 3,00 | 1,62 | 1,85 | 2,75 | 1,92 | 1,43 | — | — | — |
| -7 | 2,99 | 0,91 | 3,29 | 3,30 | 1,18 | 2,80 | 3,25 | 1,47 | 2,21 | 3,20 | 1,79 | 1,79 | 3,00 | 1,88 | 1,60 |
| 2 | 2,92 | 0,69 | 4,23 | 3,20 | 0,88 | 3,64 | 3,20 | 1,13 | 2,83 | 3,20 | 1,46 | 2,19 | 3,15 | 1,67 | 1,89 |
| 7 | 3,09 | 0,49 | 6,31 | 3,20 | 0,60 | 5,33 | 3,20 | 0,84 | 3,81 | 3,20 | 1,14 | 2,81 | 2,95 | 1,22 | 2,42 |
| 25 | 3,27 | 0,23 | 14,22 | 3,27 | 0,38 | 8,61 | 3,61 | 0,63 | 5,73 | 4,06 | 1,11 | 3,66 | 4,03 | 1,14 | 3,54 |

WH-UD05JE5

| Tamb | HC | IP | COP | HC | IP | COP | HC | IP | COP | HC | IP | COP | HC | IP | COP |
|------|------|------|------|------|------|------|------|------|------|------|------|------|------|------|------|
| LWC | 25 | 25 | 25 | 35 | 35 | 35 | 45 | 45 | 45 | 55 | 55 | 55 | 60 | 60 | 60 |
| -20 | 3,60 | 1,57 | 2,29 | 3,51 | 1,81 | 1,94 | 3,16 | 1,99 | 1,59 | 2,46 | 2,11 | 1,17 | — | — | — |
| -15 | 4,46 | 1,72 | 2,59 | 4,20 | 1,93 | 2,18 | 3,75 | 2,18 | 1,72 | 3,00 | 2,12 | 1,42 | — | — | — |
| -7 | 4,18 | 1,33 | 3,14 | 4,20 | 1,62 | 2,59 | 3,80 | 1,82 | 2,09 | 3,55 | 2,08 | 1,71 | 3,25 | 2,15 | 1,51 |
| 2 | 4,07 | 1,01 | 4,03 | 4,20 | 1,32 | 3,18 | 4,20 | 1,64 | 2,56 | 4,10 | 2,06 | 1,99 | 4,10 | 2,21 | 1,86 |
| 7 | 5,20 | 0,83 | 6,27 | 5,00 | 1,00 | 5,00 | 5,00 | 1,41 | 3,55 | 5,00 | 1,84 | 2,72 | 4,25 | 2,10 | 2,02 |
| 25 | 5,00 | 0,52 | 9,62 | 5,00 | 0,72 | 6,94 | 5,30 | 0,98 | 5,41 | 5,60 | 1,27 | 4,41 | 4,80 | 1,27 | 3,78 |

WH-UD07JE5

| Tamb | HC | IP | COP | HC | IP | COP | HC | IP | COP | HC | IP | COP | HC | IP | COP |
|------|------|------|-------|------|------|------|------|------|------|------|------|------|------|------|------|
| LWC | 25 | 25 | 25 | 35 | 35 | 35 | 45 | 45 | 45 | 55 | 55 | 55 | 60 | 60 | 60 |
| -20 | 4,33 | 1,64 | 2,64 | 3,98 | 1,88 | 2,12 | 3,83 | 2,26 | 1,69 | 3,30 | 2,77 | 1,19 | — | — | — |
| -15 | 5,16 | 1,69 | 3,05 | 4,75 | 2,00 | 2,38 | 4,65 | 2,40 | 1,94 | 4,50 | 2,96 | 1,52 | — | — | — |
| -7 | 5,64 | 1,56 | 3,62 | 5,60 | 1,95 | 2,87 | 5,50 | 2,30 | 2,39 | 5,25 | 2,70 | 1,94 | 4,98 | 2,90 | 1,72 |
| 2 | 6,80 | 1,57 | 4,33 | 6,85 | 2,01 | 3,41 | 6,75 | 2,40 | 2,81 | 6,20 | 2,80 | 2,21 | 6,18 | 2,91 | 2,12 |
| 7 | 7,55 | 1,15 | 6,57 | 7,00 | 1,47 | 4,76 | 7,00 | 1,96 | 3,57 | 7,00 | 2,48 | 2,82 | 6,86 | 2,75 | 2,49 |
| 25 | 7,00 | 0,62 | 11,29 | 6,88 | 0,90 | 7,64 | 7,00 | 1,33 | 5,26 | 6,92 | 1,75 | 3,95 | 6,83 | 1,90 | 3,59 |

WH-UD09JE5-1

| Tamb | HC | IP | COP | HC | IP | COP | HC | IP | COP | HC | IP | COP | HC | IP | COP |
|------|------|------|------|------|------|------|------|------|------|------|------|------|------|------|------|
| LWC | 25 | 25 | 25 | 35 | 35 | 35 | 45 | 45 | 45 | 55 | 55 | 55 | 60 | 60 | 60 |
| -20 | 4,95 | 1,93 | 2,56 | 6,20 | 3,00 | 2,07 | 5,28 | 3,09 | 1,71 | 4,23 | 3,33 | 1,27 | — | — | — |
| -15 | 7,58 | 2,70 | 2,81 | 7,40 | 3,20 | 2,31 | 6,29 | 3,26 | 1,93 | 5,20 | 3,42 | 1,52 | — | — | — |
| -7 | 6,39 | 1,81 | 3,53 | 6,12 | 2,20 | 2,78 | 5,88 | 2,61 | 2,25 | 5,90 | 3,06 | 1,93 | 5,65 | 3,24 | 1,74 |
| 2 | 6,96 | 1,61 | 4,32 | 7,00 | 2,06 | 3,40 | 6,85 | 2,50 | 2,74 | 6,30 | 2,92 | 2,16 | 7,26 | 3,33 | 2,18 |
| 7 | 9,44 | 1,55 | 6,09 | 9,00 | 2,01 | 4,48 | 9,00 | 2,61 | 3,45 | 8,95 | 3,22 | 2,78 | 8,62 | 3,47 | 2,48 |
| 25 | 8,27 | 0,95 | 8,71 | 8,12 | 1,29 | 6,29 | 8,71 | 1,80 | 4,84 | 7,83 | 1,97 | 3,97 | 6,08 | 1,72 | 3,53 |

Tamb: Ambient Temperature (°C). LWC: Leaving Water Condenser Temperature (°C). HC: Heating Capacity (kW). CC: Cooling Capacity (kW). IP: Power Input (kW)
This data is measured by Panasonic in accordance with EN14511-2 standard. This data is for reference purpose only, and does not guarantee the performance.

Aquarea High Performance Bi-bloc J Generation Single Phase. Heating and Cooling • R32 refrigerant

WH-UD03JE5

| Tamb | CC | IP | EER | CC | IP | EER | CC | IP | EER |
|------|------|------|------|------|------|------|------|------|------|
| LWC | 7 | 7 | 7 | 14 | 14 | 14 | 18 | 18 | 18 |
| 16 | 3,56 | 0,57 | 6,25 | 4,32 | 0,55 | 7,85 | 3,47 | 0,41 | 8,46 |
| 25 | 3,29 | 0,73 | 4,51 | 4,06 | 0,72 | 5,64 | 3,27 | 0,52 | 6,29 |
| 35 | 3,20 | 0,91 | 3,52 | 3,56 | 0,93 | 3,83 | 3,20 | 0,68 | 4,71 |
| 43 | 2,68 | 1,06 | 2,53 | 3,34 | 1,09 | 3,06 | 2,79 | 0,82 | 3,40 |

WH-UD05JE5

| Tamb | CC | IP | EER | CC | IP | EER | CC | IP | EER |
|------|------|------|------|------|------|------|------|------|------|
| LWC | 7 | 7 | 7 | 14 | 14 | 14 | 18 | 18 | 18 |
| 16 | 3,59 | 0,56 | 6,41 | 4,23 | 0,54 | 7,83 | 4,79 | 0,52 | 9,21 |
| 25 | 4,61 | 1,18 | 3,91 | 5,54 | 1,21 | 4,58 | 5,23 | 0,90 | 5,81 |
| 35 | 4,50 | 1,50 | 3,00 | 5,08 | 1,51 | 3,36 | 4,80 | 1,12 | 4,29 |
| 43 | 3,77 | 1,71 | 2,20 | 4,94 | 1,80 | 2,74 | 4,30 | 1,35 | 3,19 |

WH-UD07JE5

| Tamb | CC | IP | EER | CC | IP | EER | CC | IP | EER |
|------|------|------|------|------|------|------|------|------|------|
| LWC | 7 | 7 | 7 | 14 | 14 | 14 | 18 | 18 | 18 |
| 16 | 5,20 | 0,81 | 6,42 | 6,62 | 0,73 | 9,07 | 7,04 | 0,72 | 9,78 |
| 25 | 7,40 | 1,73 | 4,28 | 9,30 | 1,78 | 5,22 | 7,65 | 1,10 | 6,95 |
| 35 | 6,70 | 2,21 | 3,03 | 8,10 | 2,23 | 3,63 | 6,70 | 1,42 | 4,72 |
| 43 | 4,50 | 1,99 | 2,26 | 5,44 | 2,00 | 2,72 | 5,10 | 1,71 | 2,98 |

WH-UD09JE5-1

| Tamb | CC | IP | EER | CC | IP | EER | CC | IP | EER |
|------|------|------|------|-------|------|------|------|------|------|
| LWC | 7 | 7 | 7 | 14 | 14 | 14 | 18 | 18 | 18 |
| 16 | 6,85 | 1,18 | 5,81 | 8,80 | 1,15 | 7,65 | 9,11 | 1,15 | 7,92 |
| 25 | 9,00 | 2,35 | 3,83 | 10,40 | 2,48 | 4,19 | 9,10 | 1,58 | 5,76 |
| 35 | 8,20 | 3,02 | 2,72 | 9,90 | 3,02 | 3,28 | 9,00 | 2,15 | 4,19 |
| 43 | 3,80 | 1,99 | 1,91 | 4,70 | 1,97 | 2,39 | 5,35 | 1,99 | 2,69 |

Tamb: Ambient Temperature (°C). LWC: Leaving Water Condenser Temperature (°C). HC: Heating Capacity (kW). CC: Cooling Capacity (kW). IP: Power Input (kW)
 This data is measured by Panasonic in accordance with EN14511-2 standard. This data is for reference purpose only, and does not guarantee the performance.

Heating & Cooling capacity tables

Based on outlet temperature and outside temperature.

Aquarea High Performance Bi-bloc H Generation Single Phase. Heating and Cooling • R410A refrigerant

WH-UD03HE5-1

| Tamb | HC | IP | COP | HC | IP | COP | HC | IP | COP | HC | IP | COP | HC | IP | COP | HC | IP | COP |
|------|------|------|------|------|------|------|------|------|------|------|------|------|------|------|------|------|------|------|
| LWC | 30 | 30 | 30 | 35 | 35 | 35 | 40 | 40 | 40 | 45 | 45 | 45 | 50 | 50 | 50 | 55 | 55 | 55 |
| -15 | 3,20 | 1,26 | 2,54 | 3,20 | 1,39 | 2,30 | 3,10 | 1,52 | 2,04 | 3,00 | 1,64 | 1,83 | 2,80 | 1,78 | 1,57 | 2,75 | 1,92 | 1,43 |
| -7 | 3,20 | 1,08 | 2,96 | 3,20 | 1,19 | 2,69 | 3,20 | 1,34 | 2,39 | 3,20 | 1,48 | 2,16 | 3,20 | 1,67 | 1,92 | 3,20 | 1,86 | 1,72 |
| 2 | 3,20 | 0,82 | 3,90 | 3,20 | 0,90 | 3,56 | 3,20 | 1,03 | 3,11 | 3,20 | 1,16 | 2,76 | 3,20 | 1,33 | 2,41 | 3,20 | 1,49 | 2,15 |
| 7 | 3,20 | 0,58 | 5,52 | 3,20 | 0,64 | 5,00 | 3,20 | 0,77 | 4,16 | 3,20 | 0,89 | 3,60 | 3,20 | 1,05 | 3,05 | 3,20 | 1,20 | 2,67 |
| 16 | 3,20 | 0,50 | 6,40 | 3,20 | 0,55 | 5,82 | 3,20 | 0,64 | 5,00 | 3,20 | 0,72 | 4,44 | 3,20 | 0,86 | 3,72 | 3,20 | 0,99 | 3,23 |
| 25 | 3,20 | 0,42 | 7,62 | 3,20 | 0,46 | 6,96 | 3,20 | 0,55 | 5,82 | 3,20 | 0,63 | 5,08 | 3,20 | 0,73 | 4,38 | 3,20 | 0,82 | 3,90 |

WH-UD05HE5-1

| Tamb | HC | IP | COP | HC | IP | COP | HC | IP | COP | HC | IP | COP | HC | IP | COP | HC | IP | COP |
|------|------|------|------|------|------|------|------|------|------|------|------|------|------|------|------|------|------|------|
| LWC | 30 | 30 | 30 | 35 | 35 | 35 | 40 | 40 | 40 | 45 | 45 | 45 | 50 | 50 | 50 | 55 | 55 | 55 |
| -15 | 4,20 | 1,75 | 2,40 | 4,20 | 1,94 | 2,16 | 3,80 | 1,96 | 1,94 | 3,40 | 1,98 | 1,72 | 3,20 | 2,05 | 1,56 | 3,00 | 2,12 | 1,42 |
| -7 | 4,20 | 1,46 | 2,88 | 4,20 | 1,62 | 2,59 | 4,00 | 1,72 | 2,33 | 3,80 | 1,82 | 2,09 | 3,70 | 1,95 | 1,90 | 3,55 | 2,08 | 1,71 |
| 2 | 4,20 | 1,22 | 3,44 | 4,20 | 1,35 | 3,11 | 4,20 | 1,50 | 2,80 | 4,20 | 1,65 | 2,55 | 4,15 | 1,86 | 2,23 | 4,10 | 2,07 | 1,98 |
| 7 | 5,00 | 0,97 | 5,15 | 5,00 | 1,08 | 4,63 | 5,00 | 1,28 | 3,91 | 5,00 | 1,48 | 3,38 | 5,00 | 1,68 | 2,98 | 5,00 | 1,89 | 2,65 |
| 16 | 5,00 | 0,83 | 6,02 | 5,00 | 0,92 | 5,43 | 5,00 | 1,15 | 4,35 | 5,00 | 1,38 | 3,62 | 5,00 | 1,53 | 3,27 | 5,00 | 1,68 | 2,98 |
| 25 | 5,00 | 0,74 | 6,76 | 5,00 | 0,82 | 6,10 | 5,00 | 1,02 | 4,90 | 5,00 | 1,22 | 4,10 | 5,00 | 1,35 | 3,70 | 5,00 | 1,49 | 3,36 |

WH-UD07HE5-1

| Tamb | HC | IP | COP | HC | IP | COP | HC | IP | COP | HC | IP | COP | HC | IP | COP | HC | IP | COP |
|------|----|----|-----|------|------|------|------|------|------|------|------|------|------|------|------|------|------|------|
| LWC | 30 | 30 | 30 | 35 | 35 | 35 | 40 | 40 | 40 | 45 | 45 | 45 | 50 | 50 | 50 | 55 | 55 | 55 |
| -15 | — | — | — | 4,60 | 1,98 | 2,32 | 4,60 | 2,19 | 2,10 | 4,60 | 2,40 | 1,92 | 4,55 | 2,63 | 1,73 | 4,50 | 2,86 | 1,57 |
| -7 | — | — | — | 5,15 | 1,92 | 2,68 | 5,08 | 2,14 | 2,37 | 5,00 | 2,36 | 2,12 | 4,90 | 2,45 | 2,00 | 4,80 | 2,54 | 1,89 |
| 2 | — | — | — | 6,55 | 1,96 | 3,34 | 6,58 | 2,29 | 2,87 | 6,60 | 2,62 | 2,52 | 6,30 | 2,82 | 2,23 | 6,00 | 3,01 | 1,99 |
| 7 | — | — | — | 7,00 | 1,57 | 4,46 | 7,00 | 1,84 | 3,80 | 7,00 | 2,10 | 3,33 | 6,90 | 2,35 | 2,94 | 6,80 | 2,59 | 2,63 |
| 25 | — | — | — | 7,00 | 0,97 | 7,22 | 6,74 | 1,14 | 5,91 | 6,48 | 1,31 | 4,95 | 6,24 | 1,43 | 4,36 | 6,00 | 1,55 | 3,87 |

WH-UD09HE5-1

| Tamb | HC | IP | COP | HC | IP | COP | HC | IP | COP | HC | IP | COP | HC | IP | COP | HC | IP | COP |
|------|----|----|-----|------|------|------|------|------|------|------|------|------|------|------|------|------|------|------|
| LWC | 30 | 30 | 30 | 35 | 35 | 35 | 40 | 40 | 40 | 45 | 45 | 45 | 50 | 50 | 50 | 55 | 55 | 55 |
| -15 | — | — | — | 5,90 | 2,66 | 2,22 | 5,65 | 2,82 | 2,00 | 5,40 | 2,98 | 1,81 | 5,20 | 3,08 | 1,69 | 5,00 | 3,18 | 1,57 |
| -7 | — | — | — | 5,90 | 2,34 | 2,52 | 5,85 | 2,61 | 2,24 | 5,80 | 2,88 | 2,01 | 5,80 | 2,98 | 1,95 | 5,80 | 3,08 | 1,88 |
| 2 | — | — | — | 6,70 | 2,14 | 3,13 | 6,65 | 2,38 | 2,79 | 6,60 | 2,62 | 2,52 | 6,30 | 2,82 | 2,23 | 6,00 | 3,01 | 1,99 |
| 7 | — | — | — | 9,00 | 2,18 | 4,13 | 9,00 | 2,49 | 3,61 | 9,00 | 2,79 | 3,23 | 8,95 | 3,25 | 2,75 | 8,90 | 3,70 | 2,41 |
| 25 | — | — | — | 9,00 | 1,26 | 7,14 | 8,66 | 1,48 | 5,85 | 8,32 | 1,69 | 4,92 | 8,03 | 1,85 | 4,34 | 7,74 | 2,01 | 3,85 |

WH-UD12HE5

| Tamb | HC | IP | COP | HC | IP | COP | HC | IP | COP | HC | IP | COP | HC | IP | COP | HC | IP | COP |
|------|-------|------|------|-------|------|------|-------|------|------|-------|------|------|-------|------|------|-------|------|------|
| LWC | 30 | 30 | 30 | 35 | 35 | 35 | 40 | 40 | 40 | 45 | 45 | 45 | 50 | 50 | 50 | 55 | 55 | 55 |
| -15 | 9,30 | 3,46 | 2,69 | 8,90 | 3,62 | 2,46 | 8,50 | 3,79 | 2,24 | 8,10 | 3,95 | 2,05 | 7,50 | 4,05 | 1,85 | 7,00 | 4,16 | 1,68 |
| -7 | 10,40 | 3,37 | 3,09 | 10,00 | 3,66 | 2,73 | 9,60 | 3,95 | 2,43 | 9,20 | 4,24 | 2,17 | 8,70 | 4,26 | 2,04 | 8,20 | 4,27 | 1,92 |
| 2 | 11,80 | 3,10 | 3,81 | 11,40 | 3,31 | 3,44 | 11,00 | 3,53 | 3,12 | 10,60 | 3,74 | 2,83 | 9,80 | 3,94 | 2,49 | 9,10 | 4,14 | 2,20 |
| 7 | 12,00 | 2,10 | 5,71 | 12,00 | 2,53 | 4,74 | 12,00 | 2,96 | 4,05 | 12,00 | 3,39 | 3,54 | 12,00 | 3,78 | 3,17 | 12,00 | 4,16 | 2,88 |
| 25 | 12,00 | 1,38 | 8,70 | 12,00 | 1,66 | 7,23 | 11,80 | 1,94 | 6,08 | 11,70 | 2,23 | 5,25 | 11,50 | 2,49 | 4,62 | 11,40 | 2,74 | 4,16 |

WH-UD16HE5

| Tamb | HC | IP | COP | HC | IP | COP | HC | IP | COP | HC | IP | COP | HC | IP | COP | HC | IP | COP |
|------|-------|------|------|-------|------|------|-------|------|------|-------|------|------|-------|------|------|-------|------|------|
| LWC | 30 | 30 | 30 | 35 | 35 | 35 | 40 | 40 | 40 | 45 | 45 | 45 | 50 | 50 | 50 | 55 | 55 | 55 |
| -15 | 10,60 | 4,09 | 2,59 | 10,30 | 4,38 | 2,35 | 10,00 | 4,67 | 2,14 | 9,70 | 4,96 | 1,96 | 8,80 | 4,94 | 1,78 | 7,90 | 4,91 | 1,61 |
| -7 | 11,90 | 4,03 | 2,95 | 11,40 | 4,43 | 2,57 | 10,80 | 4,83 | 2,24 | 10,30 | 5,22 | 1,97 | 9,60 | 5,09 | 1,89 | 9,00 | 4,95 | 1,82 |
| 2 | 13,50 | 3,74 | 3,61 | 13,00 | 3,96 | 3,28 | 12,40 | 4,18 | 2,97 | 11,90 | 4,40 | 2,70 | 10,80 | 4,46 | 2,42 | 9,80 | 4,51 | 2,17 |
| 7 | 16,00 | 3,21 | 4,98 | 16,00 | 3,74 | 4,28 | 16,00 | 4,27 | 3,75 | 16,00 | 4,80 | 3,33 | 15,20 | 5,11 | 2,97 | 14,50 | 5,41 | 2,68 |
| 25 | 16,00 | 2,31 | 6,93 | 16,00 | 2,69 | 5,95 | 16,00 | 3,07 | 5,21 | 16,00 | 3,45 | 4,64 | 16,00 | 3,67 | 4,36 | 15,90 | 3,89 | 4,09 |

Tamb: Ambient Temperature (°C). LWC: Leaving Water Condenser Temperature (°C). HC: Heating Capacity (kW). CC: Cooling Capacity (kW). IP: Power Input (kW). This data is measured by Panasonic in accordance with EN14511-2 standard. This data is for reference purpose only, and does not guarantee the performance.

Aquaarea High Performance Bi-bloc H Generation Single Phase. Heating and Cooling • R410A refrigerant

WH-UD03HE5-1

| Tamb | CC | IP | EER | CC | IP | EER | CC | IP | EER |
|------|------|------|------|------|------|------|------|------|------|
| LWC | 7 | 7 | 7 | 14 | 14 | 14 | 18 | 18 | 18 |
| 18 | 2,40 | 0,42 | 5,71 | 4,40 | 0,73 | 6,03 | 3,70 | 0,49 | 7,55 |
| 25 | 3,20 | 0,73 | 4,38 | 4,10 | 0,86 | 4,77 | 3,50 | 0,59 | 5,93 |
| 35 | 3,20 | 1,04 | 3,08 | 3,90 | 1,07 | 3,64 | 3,30 | 0,74 | 4,46 |
| 43 | 2,90 | 1,20 | 2,42 | 3,50 | 1,20 | 2,92 | 3,00 | 0,88 | 3,41 |

WH-UD05HE5-1

| Tamb | CC | IP | EER | CC | IP | EER | CC | IP | EER |
|------|------|------|------|------|------|------|------|------|------|
| LWC | 7 | 7 | 7 | 14 | 14 | 14 | 18 | 18 | 18 |
| 18 | 4,50 | 0,89 | 5,06 | 5,00 | 0,90 | 5,56 | 5,70 | 0,90 | 6,33 |
| 25 | 5,00 | 1,43 | 3,50 | 6,30 | 1,50 | 4,20 | 5,40 | 1,06 | 5,09 |
| 35 | 4,50 | 1,67 | 2,69 | 5,50 | 1,68 | 3,27 | 5,00 | 1,33 | 3,76 |
| 43 | 3,30 | 1,53 | 2,16 | 4,10 | 1,52 | 2,70 | 4,40 | 1,53 | 2,88 |

WH-UD07HE5-1

| Tamb | CC | IP | EER | CC | IP | EER | CC | IP | EER |
|------|------|------|------|------|------|------|------|------|------|
| LWC | 7 | 7 | 7 | 14 | 14 | 14 | 18 | 18 | 18 |
| 18 | 4,80 | 0,80 | 6,00 | 7,20 | 1,16 | 6,21 | 6,00 | 1,13 | 5,31 |
| 25 | 7,00 | 1,90 | 3,68 | 8,47 | 1,78 | 4,76 | 6,00 | 1,27 | 4,72 |
| 35 | 6,00 | 2,28 | 2,63 | 6,60 | 2,48 | 2,66 | 6,00 | 1,68 | 3,57 |
| 43 | 4,85 | 2,65 | 1,83 | 6,00 | 2,82 | 2,13 | 4,80 | 1,98 | 2,42 |

WH-UD09HE5-1

| Tamb | CC | IP | EER | CC | IP | EER | CC | IP | EER |
|------|------|------|------|-------|------|------|------|------|------|
| LWC | 7 | 7 | 7 | 14 | 14 | 14 | 18 | 18 | 18 |
| 18 | 5,40 | 1,00 | 5,40 | 8,40 | 1,62 | 5,19 | 7,00 | 1,61 | 4,35 |
| 25 | 7,85 | 2,40 | 3,27 | 10,20 | 2,46 | 4,15 | 7,00 | 1,77 | 3,95 |
| 35 | 7,00 | 2,88 | 2,43 | 7,60 | 3,20 | 2,38 | 7,00 | 2,15 | 3,26 |
| 43 | 5,20 | 2,85 | 1,82 | 6,99 | 3,84 | 1,82 | 5,60 | 2,55 | 2,20 |

WH-UD12HE5

| Tamb | CC | IP | EER | CC | IP | EER | CC | IP | EER |
|------|-------|------|------|-------|------|------|-------|------|------|
| LWC | 7 | 7 | 7 | 14 | 14 | 14 | 18 | 18 | 18 |
| 16 | 7,86 | 1,18 | 6,66 | 13,15 | 1,40 | 9,39 | 10,00 | 1,73 | 5,78 |
| 25 | 12,08 | 2,90 | 4,17 | 15,70 | 2,05 | 7,66 | 10,00 | 1,97 | 5,08 |
| 35 | 10,00 | 2,56 | 3,91 | 12,00 | 2,67 | 4,49 | 10,00 | 2,40 | 4,17 |
| 43 | 7,80 | 3,80 | 2,05 | 11,10 | 3,19 | 3,48 | 8,00 | 2,85 | 2,81 |

WH-UD16HE5

| Tamb | CC | IP | EER | CC | IP | EER | CC | IP | EER |
|------|-------|------|------|-------|------|------|-------|------|------|
| LWC | 7 | 7 | 7 | 14 | 14 | 14 | 18 | 18 | 18 |
| 16 | 9,20 | 1,62 | 5,68 | 16,40 | 2,58 | 6,36 | 12,20 | 2,45 | 4,98 |
| 25 | 14,40 | 3,92 | 3,67 | 19,20 | 3,83 | 5,01 | 12,20 | 2,79 | 4,37 |
| 35 | 12,20 | 4,76 | 2,56 | 15,00 | 4,98 | 3,01 | 12,20 | 2,96 | 4,12 |
| 43 | 7,75 | 3,40 | 2,28 | 13,80 | 5,95 | 2,32 | 9,70 | 4,00 | 2,43 |

Tamb: Ambient Temperature (°C). LWC: Leaving Water Condenser Temperature (°C). HC: Heating Capacity (kW). CC: Cooling Capacity (kW). IP: Power Input (kW). This data is measured by Panasonic in accordance with EN14511-2 standard. This data is for reference purpose only, and does not guarantee the performance.

Heating & Cooling capacity tables

Based on outlet temperature and outside temperature.

Aquarea High Performance Bi-bloc H Generation Three Phase. Heating and Cooling • R410A refrigerant

| WH-UD09HE8 | | | | | | | | | | | | | | | | | | |
|------------|-------|------|------|-------|------|------|-------|------|------|-------|------|------|-------|------|------|-------|------|------|
| Tamb | HC | IP | COP | HC | IP | COP | HC | IP | COP | HC | IP | COP | HC | IP | COP | HC | IP | COP |
| LWC | 30 | 30 | 30 | 35 | 35 | 35 | 40 | 40 | 40 | 45 | 45 | 45 | 50 | 50 | 50 | 55 | 55 | 55 |
| -15 | 8,65 | 3,06 | 2,83 | 8,30 | 3,21 | 2,59 | 7,95 | 3,41 | 2,33 | 7,60 | 3,61 | 2,11 | 7,15 | 3,71 | 1,93 | 6,70 | 3,81 | 1,76 |
| -7 | 9,35 | 2,91 | 3,21 | 9,00 | 3,16 | 2,85 | 8,85 | 3,54 | 2,50 | 8,70 | 3,92 | 2,22 | 8,30 | 3,89 | 2,13 | 7,90 | 3,86 | 2,05 |
| 2 | 9,31 | 2,35 | 3,96 | 9,00 | 2,51 | 3,59 | 9,00 | 2,78 | 3,24 | 9,00 | 3,05 | 2,95 | 8,90 | 3,49 | 2,55 | 8,80 | 3,94 | 2,23 |
| 7 | 9,00 | 1,54 | 5,84 | 9,00 | 1,86 | 4,84 | 9,00 | 2,16 | 4,17 | 9,00 | 2,46 | 3,66 | 9,00 | 2,76 | 3,26 | 9,00 | 3,06 | 2,94 |
| 25 | 9,00 | 1,05 | 8,57 | 9,00 | 1,24 | 7,26 | 8,73 | 1,44 | 6,06 | 8,46 | 1,64 | 5,16 | 8,28 | 1,82 | 4,55 | 8,10 | 2,00 | 4,05 |
| WH-UD12HE8 | | | | | | | | | | | | | | | | | | |
| Tamb | HC | IP | COP | HC | IP | COP | HC | IP | COP | HC | IP | COP | HC | IP | COP | HC | IP | COP |
| LWC | 30 | 30 | 30 | 35 | 35 | 35 | 40 | 40 | 40 | 45 | 45 | 45 | 50 | 50 | 50 | 55 | 55 | 55 |
| -15 | 9,30 | 3,46 | 2,69 | 8,90 | 3,62 | 2,46 | 8,50 | 3,79 | 2,24 | 8,10 | 3,95 | 2,05 | 7,50 | 4,05 | 1,85 | 7,00 | 4,16 | 1,68 |
| -7 | 10,40 | 3,37 | 3,09 | 10,00 | 3,66 | 2,73 | 9,60 | 3,95 | 2,43 | 9,20 | 4,24 | 2,17 | 8,70 | 4,26 | 2,04 | 8,20 | 4,27 | 1,92 |
| 2 | 11,80 | 3,10 | 3,81 | 11,40 | 3,31 | 3,44 | 11,00 | 3,53 | 3,12 | 10,60 | 3,74 | 2,83 | 9,80 | 3,94 | 2,49 | 9,10 | 4,14 | 2,20 |
| 7 | 12,00 | 2,10 | 5,71 | 12,00 | 2,53 | 4,74 | 12,00 | 2,96 | 4,05 | 12,00 | 3,39 | 3,54 | 12,00 | 3,78 | 3,17 | 12,00 | 4,16 | 2,88 |
| 25 | 12,00 | 1,38 | 8,70 | 12,00 | 1,66 | 7,23 | 11,80 | 1,94 | 6,08 | 11,70 | 2,23 | 5,25 | 11,50 | 2,49 | 4,62 | 11,40 | 2,74 | 4,16 |
| WH-UD16HE8 | | | | | | | | | | | | | | | | | | |
| Tamb | HC | IP | COP | HC | IP | COP | HC | IP | COP | HC | IP | COP | HC | IP | COP | HC | IP | COP |
| LWC | 30 | 30 | 30 | 35 | 35 | 35 | 40 | 40 | 40 | 45 | 45 | 45 | 50 | 50 | 50 | 55 | 55 | 55 |
| -15 | 10,60 | 4,09 | 2,59 | 10,30 | 4,38 | 2,35 | 10,00 | 4,67 | 2,14 | 9,70 | 4,96 | 1,96 | 8,80 | 4,94 | 1,78 | 7,90 | 4,91 | 1,61 |
| -7 | 11,90 | 4,03 | 2,95 | 11,40 | 4,43 | 2,57 | 10,80 | 4,83 | 2,24 | 10,30 | 5,22 | 1,97 | 9,60 | 5,09 | 1,89 | 9,00 | 4,95 | 1,82 |
| 2 | 13,50 | 3,74 | 3,61 | 13,00 | 3,96 | 3,28 | 12,40 | 4,18 | 2,97 | 11,90 | 4,40 | 2,70 | 10,80 | 4,46 | 2,42 | 9,80 | 4,51 | 2,17 |
| 7 | 16,00 | 3,21 | 4,98 | 16,00 | 3,74 | 4,28 | 16,00 | 4,27 | 3,75 | 16,00 | 4,80 | 3,33 | 15,20 | 5,11 | 2,97 | 14,50 | 5,41 | 2,68 |
| 25 | 16,00 | 2,31 | 6,93 | 16,00 | 2,69 | 5,95 | 16,00 | 3,07 | 5,21 | 16,00 | 3,45 | 4,64 | 16,00 | 3,67 | 4,36 | 15,90 | 3,89 | 4,09 |

Aquarea High Performance Bi-bloc H Generation Three Phase. Heating and Cooling • R410A refrigerant

| WH-UD09HE8 | | | | | | | | | |
|------------|-------|------|------|-------|------|------|-------|------|------|
| Tamb | CC | IP | EER | CC | IP | EER | CC | IP | EER |
| LWC | 7 | 7 | 7 | 14 | 14 | 14 | 18 | 18 | 18 |
| 16 | 7,50 | 1,15 | 6,52 | 9,10 | 1,20 | 7,58 | 7,00 | 1,13 | 6,19 |
| 25 | 8,35 | 1,77 | 4,72 | 10,90 | 1,78 | 6,12 | 7,00 | 1,24 | 5,65 |
| 35 | 7,00 | 2,23 | 3,14 | 8,30 | 2,32 | 3,58 | 7,00 | 1,52 | 4,61 |
| 43 | 5,52 | 2,54 | 2,17 | 7,69 | 2,77 | 2,78 | 5,60 | 1,80 | 3,11 |
| WH-UD12HE8 | | | | | | | | | |
| Tamb | CC | IP | EER | CC | IP | EER | CC | IP | EER |
| LWC | 7 | 7 | 7 | 14 | 14 | 14 | 18 | 18 | 18 |
| 16 | 7,86 | 1,18 | 6,66 | 13,15 | 1,40 | 9,39 | 10,00 | 1,73 | 5,78 |
| 25 | 12,08 | 2,90 | 4,17 | 15,70 | 2,05 | 7,66 | 10,00 | 1,97 | 5,08 |
| 35 | 10,00 | 2,56 | 3,91 | 12,00 | 2,67 | 4,49 | 10,00 | 2,40 | 4,17 |
| 43 | 7,80 | 3,80 | 2,05 | 11,10 | 3,19 | 3,48 | 8,00 | 2,85 | 2,81 |
| WH-UD16HE8 | | | | | | | | | |
| Tamb | CC | IP | EER | CC | IP | EER | CC | IP | EER |
| LWC | 7 | 7 | 7 | 14 | 14 | 14 | 18 | 18 | 18 |
| 16 | 9,20 | 1,62 | 5,68 | 16,40 | 2,58 | 6,36 | 12,20 | 2,45 | 4,98 |
| 25 | 14,40 | 3,92 | 3,67 | 19,20 | 3,83 | 5,01 | 12,20 | 2,79 | 4,37 |
| 35 | 12,20 | 4,76 | 2,56 | 15,00 | 4,98 | 3,01 | 12,20 | 2,96 | 4,12 |
| 43 | 7,75 | 3,40 | 2,28 | 13,80 | 5,95 | 2,32 | 9,70 | 4,00 | 2,43 |

Tamb: Ambient Temperature (°C). LWC: Leaving Water Condenser Temperature (°C). HC: Heating Capacity (kW). CC: Cooling Capacity (kW). IP: Power Input (kW). This data is measured by Panasonic in accordance with EN14511-2 standard. This data is for reference purpose only, and does not guarantee the performance.

Aquarea T-CAP Bi-bloc H Generation Single Phase / Three Phase. Heating and Cooling • R410A refrigerant

WH-UX09HE5

| Tamb | HC | IP | COP | HC | IP | COP | HC | IP | COP | HC | IP | COP | HC | IP | COP | HC | IP | COP |
|------|-------|------|------|-------|------|------|-------|------|------|-------|------|------|-------|------|------|-------|------|------|
| LWC | 30 | 30 | 30 | 35 | 35 | 35 | 40 | 40 | 40 | 45 | 45 | 45 | 50 | 50 | 50 | 55 | 55 | 55 |
| -15 | 9,00 | 3,24 | 2,78 | 9,00 | 3,51 | 2,56 | 9,00 | 3,91 | 2,30 | 9,00 | 4,30 | 2,09 | 9,00 | 4,73 | 1,90 | 9,00 | 5,16 | 1,74 |
| -7 | 9,00 | 2,71 | 3,32 | 9,00 | 3,16 | 2,85 | 9,00 | 3,62 | 2,49 | 9,00 | 4,07 | 2,21 | 9,00 | 4,27 | 2,11 | 9,00 | 4,46 | 2,02 |
| 2 | 9,00 | 2,36 | 3,81 | 9,00 | 2,51 | 3,59 | 9,00 | 2,78 | 3,24 | 9,00 | 3,05 | 2,95 | 9,00 | 3,56 | 2,53 | 9,00 | 4,07 | 2,21 |
| 7 | 9,00 | 1,64 | 5,49 | 9,00 | 1,86 | 4,84 | 9,00 | 2,16 | 4,17 | 9,00 | 2,46 | 3,66 | 9,00 | 2,76 | 3,26 | 9,00 | 3,06 | 2,94 |
| 25 | 13,60 | 1,50 | 9,07 | 13,60 | 1,71 | 7,95 | 13,20 | 1,93 | 6,84 | 12,80 | 2,14 | 5,98 | 12,00 | 2,41 | 4,98 | 11,20 | 2,67 | 4,19 |

WH-UX12HE5

| Tamb | HC | IP | COP | HC | IP | COP | HC | IP | COP | HC | IP | COP | HC | IP | COP | HC | IP | COP |
|------|-------|------|------|-------|------|------|-------|------|------|-------|------|------|-------|------|------|-------|------|------|
| LWC | 30 | 30 | 30 | 35 | 35 | 35 | 40 | 40 | 40 | 45 | 45 | 45 | 50 | 50 | 50 | 55 | 55 | 55 |
| -15 | 12,00 | 4,75 | 2,53 | 12,00 | 4,96 | 2,42 | 12,00 | 5,41 | 2,22 | 11,00 | 5,38 | 2,04 | 10,80 | 5,82 | 1,86 | 10,50 | 6,26 | 1,68 |
| -7 | 12,00 | 3,85 | 3,12 | 12,00 | 4,41 | 2,72 | 12,00 | 4,98 | 2,41 | 12,00 | 5,54 | 2,17 | 12,00 | 5,90 | 2,03 | 12,00 | 6,26 | 1,92 |
| 2 | 12,00 | 3,19 | 3,76 | 12,00 | 3,49 | 3,44 | 12,00 | 3,87 | 3,10 | 12,00 | 4,25 | 2,82 | 12,00 | 4,86 | 2,47 | 12,00 | 5,47 | 2,19 |
| 7 | 12,00 | 2,18 | 5,50 | 12,00 | 2,53 | 4,74 | 12,00 | 2,96 | 4,05 | 12,00 | 3,39 | 3,54 | 12,00 | 3,78 | 3,17 | 12,00 | 4,16 | 2,88 |
| 25 | 13,60 | 1,55 | 8,77 | 13,60 | 1,76 | 7,73 | 13,40 | 2,10 | 6,38 | 13,20 | 2,43 | 5,43 | 12,60 | 2,66 | 4,74 | 12,00 | 2,89 | 4,15 |

WH-UX09HE8

| Tamb | HC | IP | COP | HC | IP | COP | HC | IP | COP | HC | IP | COP | HC | IP | COP | HC | IP | COP |
|------|-------|------|------|-------|------|------|-------|------|------|-------|------|------|-------|------|------|-------|------|------|
| LWC | 30 | 30 | 30 | 35 | 35 | 35 | 40 | 40 | 40 | 45 | 45 | 45 | 50 | 50 | 50 | 55 | 55 | 55 |
| -15 | 9,00 | 3,24 | 2,78 | 9,00 | 3,51 | 2,56 | 9,00 | 3,91 | 2,30 | 9,00 | 4,30 | 2,09 | 9,00 | 4,73 | 1,90 | 9,00 | 5,16 | 1,74 |
| -7 | 9,00 | 2,71 | 3,32 | 9,00 | 3,16 | 2,85 | 9,00 | 3,62 | 2,49 | 9,00 | 4,07 | 2,21 | 9,00 | 4,27 | 2,11 | 9,00 | 4,46 | 2,02 |
| 2 | 9,00 | 2,36 | 3,81 | 9,00 | 2,51 | 3,59 | 9,00 | 2,78 | 3,24 | 9,00 | 3,05 | 2,95 | 9,00 | 3,56 | 2,53 | 9,00 | 4,07 | 2,21 |
| 7 | 9,00 | 1,64 | 5,49 | 9,00 | 1,86 | 4,84 | 9,00 | 2,16 | 4,17 | 9,00 | 2,46 | 3,66 | 9,00 | 2,76 | 3,26 | 9,00 | 3,06 | 2,94 |
| 25 | 13,60 | 1,50 | 9,07 | 13,60 | 1,71 | 7,95 | 13,20 | 1,93 | 6,84 | 12,80 | 2,14 | 5,98 | 12,00 | 2,41 | 4,98 | 11,20 | 2,67 | 4,19 |

WH-UX12HE8

| Tamb | HC | IP | COP | HC | IP | COP | HC | IP | COP | HC | IP | COP | HC | IP | COP | HC | IP | COP |
|------|-------|------|------|-------|------|------|-------|------|------|-------|------|------|-------|------|------|-------|------|------|
| LWC | 30 | 30 | 30 | 35 | 35 | 35 | 40 | 40 | 40 | 45 | 45 | 45 | 50 | 50 | 50 | 55 | 55 | 55 |
| -15 | 12,00 | 4,75 | 2,53 | 12,00 | 4,96 | 2,42 | 12,00 | 5,41 | 2,22 | 12,00 | 5,86 | 2,05 | 11,80 | 6,24 | 1,89 | 11,60 | 6,62 | 1,75 |
| -7 | 12,00 | 3,85 | 3,12 | 12,00 | 4,41 | 2,72 | 12,00 | 4,98 | 2,41 | 12,00 | 5,54 | 2,17 | 12,00 | 5,90 | 2,03 | 12,00 | 6,26 | 1,92 |
| 2 | 12,00 | 3,19 | 3,76 | 12,00 | 3,49 | 3,44 | 12,00 | 3,87 | 3,10 | 12,00 | 4,25 | 2,82 | 12,00 | 4,86 | 2,47 | 12,00 | 5,47 | 2,19 |
| 7 | 12,00 | 2,18 | 5,50 | 12,00 | 2,53 | 4,74 | 12,00 | 2,96 | 4,05 | 12,00 | 3,39 | 3,54 | 12,00 | 3,78 | 3,17 | 12,00 | 4,16 | 2,88 |
| 25 | 13,60 | 1,55 | 8,77 | 13,60 | 1,76 | 7,73 | 13,40 | 2,10 | 6,38 | 13,20 | 2,43 | 5,43 | 12,60 | 2,66 | 4,74 | 12,00 | 2,89 | 4,15 |

WH-UX16HE8

| Tamb | HC | IP | COP | HC | IP | COP | HC | IP | COP | HC | IP | COP | HC | IP | COP | HC | IP | COP |
|------|-------|------|------|-------|------|------|-------|------|------|-------|------|------|-------|------|------|-------|------|------|
| LWC | 30 | 30 | 30 | 35 | 35 | 35 | 40 | 40 | 40 | 45 | 45 | 45 | 50 | 50 | 50 | 55 | 55 | 55 |
| -15 | 16,00 | 6,30 | 2,54 | 16,00 | 6,89 | 2,32 | 16,00 | 7,45 | 2,15 | 16,00 | 8,10 | 1,98 | 16,00 | 8,48 | 1,89 | 15,20 | 8,96 | 1,70 |
| -7 | 16,00 | 5,85 | 2,74 | 16,00 | 6,42 | 2,49 | 16,00 | 7,00 | 2,29 | 16,00 | 7,57 | 2,11 | 16,00 | 8,10 | 1,98 | 16,00 | 8,62 | 1,86 |
| 2 | 16,00 | 4,67 | 3,43 | 16,00 | 5,21 | 3,07 | 16,00 | 5,74 | 2,79 | 16,00 | 6,31 | 2,54 | 16,00 | 6,90 | 2,32 | 16,00 | 7,50 | 2,13 |
| 7 | 16,00 | 3,35 | 4,78 | 16,00 | 3,74 | 4,28 | 16,00 | 4,30 | 3,72 | 16,00 | 4,80 | 3,33 | 16,00 | 5,43 | 2,95 | 16,00 | 5,91 | 2,71 |
| 16 | 16,00 | 2,59 | 6,18 | 16,00 | 3,18 | 5,03 | 16,00 | 3,71 | 4,31 | 16,00 | 4,27 | 3,75 | 16,00 | 4,86 | 3,29 | 16,00 | 5,22 | 3,07 |
| 25 | 16,00 | 2,02 | 7,92 | 16,00 | 2,58 | 6,20 | 16,00 | 2,91 | 5,50 | 16,00 | 3,36 | 4,76 | 16,00 | 3,74 | 4,28 | 16,00 | 4,00 | 4,00 |

Aquarea T-CAP Bi-bloc H Generation Single Phase / Three Phase. Heating and Cooling • R410A refrigerant

| Models | WH-UX09HE5 | | | | | | | | | WH-UX12HE5 | | | | | | | | |
|--------|------------|------|------|-------|------|------|------------|------|------|------------|------|------|------------|------|------|-------|------|------|
| Tamb | CC | IP | EER | CC | IP | EER | CC | IP | EER | CC | IP | EER | CC | IP | EER | CC | IP | EER |
| LWC | 7 | 7 | 7 | 14 | 14 | 14 | 18 | 18 | 18 | 7 | 7 | 7 | 14 | 14 | 14 | 18 | 18 | 18 |
| 18 | 7,00 | 1,36 | 5,15 | 8,55 | 1,41 | 6,06 | 7,00 | 1,00 | 7,00 | 10,00 | 1,75 | 5,71 | 13,20 | 1,96 | 6,73 | 10,00 | 1,40 | 7,14 |
| 25 | 7,65 | 1,91 | 4,01 | 11,10 | 1,98 | 5,61 | 7,00 | 1,10 | 6,36 | 11,20 | 2,67 | 4,19 | 16,50 | 3,01 | 5,48 | 10,00 | 1,60 | 6,25 |
| 35 | 7,00 | 2,21 | 3,17 | 9,23 | 2,37 | 3,89 | 7,00 | 1,35 | 5,19 | 10,00 | 3,56 | 2,81 | 12,55 | 3,63 | 3,46 | 10,00 | 1,95 | 5,13 |
| 43 | 6,25 | 2,66 | 2,35 | 8,55 | 2,71 | 3,15 | 5,60 | 1,60 | 3,50 | 8,00 | 3,35 | 2,39 | 10,00 | 3,46 | 2,89 | 8,00 | 2,30 | 3,48 |
| Models | WH-UX09HE8 | | | | | | WH-UX12HE8 | | | | | | WH-UX16HE8 | | | | | |
| Tamb | CC | IP | EER | CC | IP | EER | CC | IP | EER | CC | IP | EER | CC | IP | EER | CC | IP | EER |
| LWC | 7 | 7 | 7 | 18 | 18 | 18 | 7 | 7 | 7 | 18 | 18 | 18 | 7 | 7 | 7 | 18 | 18 | 18 |
| 18 | 7,00 | 1,36 | 5,15 | — | — | — | 7,50 | 1,41 | 5,32 | — | — | — | 8,50 | 1,70 | 5,00 | 10,00 | 1,70 | 5,88 |
| 25 | 7,65 | 1,91 | 4,01 | — | — | — | 8,90 | 2,16 | 4,12 | — | — | — | 14,00 | 4,00 | 3,50 | 14,00 | 2,94 | 4,76 |
| 35 | 7,00 | 2,21 | 3,17 | — | — | — | 10,00 | 3,56 | 2,81 | — | — | — | 12,20 | 4,76 | 2,56 | 12,20 | 3,50 | 3,49 |
| 43 | 6,25 | 2,66 | 2,35 | — | — | — | 8,00 | 3,01 | 2,66 | — | — | — | 7,10 | 3,31 | 2,15 | 9,80 | 3,31 | 2,96 |

Tamb: Ambient Temperature (°C). LWC: Leaving Water Condenser Temperature (°C). HC: Heating Capacity (kW). CC: Cooling Capacity (kW). IP: Power Input (kW). This data is measured by Panasonic in accordance with EN14511-2 standard. This data is for reference purpose only, and does not guarantee the performance.

Heating & Cooling capacity tables

Based on outlet temperature and outside temperature.

Aquarea T-CAP Bi-bloc H Generation Three Phase. Super Quiet outdoor unit. Heating and Cooling - SQC • R410A refrigerant

WH-UQ09HE8

| Tamb | HC | IP | COP | HC | IP | COP | HC | IP | COP | HC | IP | COP | HC | IP | COP | HC | IP | COP |
|------|-------|------|------|-------|------|------|-------|------|------|-------|------|------|-------|------|------|-------|------|------|
| LWC | 30 | 30 | 30 | 35 | 35 | 35 | 40 | 40 | 40 | 45 | 45 | 45 | 50 | 50 | 50 | 55 | 55 | 55 |
| -15 | 9,00 | 3,24 | 2,78 | 9,00 | 3,51 | 2,56 | 9,00 | 3,91 | 2,30 | 9,00 | 4,30 | 2,09 | 9,00 | 4,73 | 1,90 | 9,00 | 5,16 | 1,74 |
| -7 | 9,00 | 2,71 | 3,32 | 9,00 | 3,16 | 2,85 | 9,00 | 3,62 | 2,49 | 9,00 | 4,07 | 2,21 | 9,00 | 4,27 | 2,11 | 9,00 | 4,46 | 2,02 |
| 2 | 9,00 | 2,36 | 3,81 | 9,00 | 2,51 | 3,59 | 9,00 | 2,78 | 3,24 | 9,00 | 3,05 | 2,95 | 9,00 | 3,56 | 2,53 | 9,00 | 4,07 | 2,21 |
| 7 | 9,00 | 1,64 | 5,49 | 9,00 | 1,86 | 4,84 | 9,00 | 2,16 | 4,17 | 9,00 | 2,46 | 3,66 | 9,00 | 2,76 | 3,26 | 9,00 | 3,06 | 2,94 |
| 25 | 13,60 | 1,50 | 9,07 | 13,60 | 1,71 | 7,95 | 13,20 | 1,93 | 6,84 | 12,80 | 2,14 | 5,98 | 12,00 | 2,41 | 4,98 | 11,20 | 2,67 | 4,19 |

WH-UQ12HE8

| Tamb | HC | IP | COP | HC | IP | COP | HC | IP | COP | HC | IP | COP | HC | IP | COP | HC | IP | COP |
|------|-------|------|------|-------|------|------|-------|------|------|-------|------|------|-------|------|------|-------|------|------|
| LWC | 30 | 30 | 30 | 35 | 35 | 35 | 40 | 40 | 40 | 45 | 45 | 45 | 50 | 50 | 50 | 55 | 55 | 55 |
| -15 | 12,00 | 4,75 | 2,53 | 12,00 | 4,96 | 2,42 | 12,00 | 5,41 | 2,22 | 12,00 | 5,86 | 2,05 | 11,80 | 6,24 | 1,89 | 11,60 | 6,62 | 1,75 |
| -7 | 12,00 | 3,85 | 3,12 | 12,00 | 4,41 | 2,72 | 12,00 | 4,98 | 2,41 | 12,00 | 5,54 | 2,17 | 12,00 | 5,90 | 2,03 | 12,00 | 6,26 | 1,92 |
| 2 | 12,00 | 3,19 | 3,76 | 12,00 | 3,49 | 3,44 | 12,00 | 3,87 | 3,10 | 12,00 | 4,25 | 2,82 | 12,00 | 4,86 | 2,47 | 12,00 | 5,47 | 2,19 |
| 7 | 12,00 | 2,18 | 5,50 | 12,00 | 2,53 | 4,74 | 12,00 | 2,96 | 4,05 | 12,00 | 3,39 | 3,54 | 12,00 | 3,78 | 3,17 | 12,00 | 4,16 | 2,88 |
| 25 | 13,60 | 1,55 | 8,77 | 13,60 | 1,76 | 7,73 | 13,40 | 2,10 | 6,38 | 13,20 | 2,43 | 5,43 | 12,60 | 2,66 | 4,74 | 12,00 | 2,89 | 4,15 |

WH-UQ16HE8

| Tamb | HC | IP | COP | HC | IP | COP | HC | IP | COP | HC | IP | COP | HC | IP | COP | HC | IP | COP |
|------|-------|------|------|-------|------|------|-------|------|------|-------|------|------|-------|------|------|-------|------|------|
| LWC | 30 | 30 | 30 | 35 | 35 | 35 | 40 | 40 | 40 | 45 | 45 | 45 | 50 | 50 | 50 | 55 | 55 | 55 |
| -15 | 16,00 | 6,30 | 2,54 | 16,00 | 6,89 | 2,32 | 16,00 | 7,45 | 2,15 | 16,00 | 8,10 | 1,98 | 16,00 | 8,48 | 1,89 | 15,20 | 8,96 | 1,70 |
| -7 | 16,00 | 5,85 | 2,74 | 16,00 | 6,42 | 2,49 | 16,00 | 7,00 | 2,29 | 16,00 | 7,57 | 2,11 | 16,00 | 8,10 | 1,98 | 16,00 | 8,62 | 1,86 |
| 2 | 16,00 | 4,67 | 3,43 | 16,00 | 5,21 | 3,07 | 16,00 | 5,74 | 2,79 | 16,00 | 6,31 | 2,54 | 16,00 | 6,90 | 2,32 | 16,00 | 7,50 | 2,13 |
| 7 | 16,00 | 3,35 | 4,78 | 16,00 | 3,74 | 4,28 | 16,00 | 4,30 | 3,72 | 16,00 | 4,80 | 3,33 | 16,00 | 5,43 | 2,95 | 16,00 | 5,91 | 2,71 |
| 16 | 16,00 | 2,59 | 6,18 | 16,00 | 3,18 | 5,03 | 16,00 | 3,71 | 4,31 | 16,00 | 4,27 | 3,75 | 16,00 | 4,86 | 3,29 | 16,00 | 5,22 | 3,07 |
| 25 | 16,00 | 2,02 | 7,92 | 16,00 | 2,58 | 6,20 | 16,00 | 2,91 | 5,50 | 16,00 | 3,36 | 4,76 | 16,00 | 3,74 | 4,28 | 16,00 | 4,00 | 4,00 |

Aquarea T-CAP Bi-bloc H Generation Three Phase. Super Quiet outdoor unit. Heating and Cooling - SQC • R410A refrigerant

WH-UQ09HE8

| Tamb | CC | IP | EER | CC | IP | EER |
|------|------|------|------|----|----|-----|
| LWC | 7 | 7 | 7 | 18 | 18 | 18 |
| 18 | 7,00 | 1,36 | 5,15 | — | — | — |
| 25 | 7,65 | 1,91 | 4,01 | — | — | — |
| 35 | 7,00 | 2,21 | 3,17 | — | — | — |
| 43 | 6,25 | 2,66 | 2,35 | — | — | — |

WH-UQ12HE8

| Tamb | CC | IP | EER | CC | IP | EER |
|------|-------|------|------|----|----|-----|
| LWC | 7 | 7 | 7 | 18 | 18 | 18 |
| 18 | 7,50 | 1,41 | 5,32 | — | — | — |
| 25 | 8,90 | 2,16 | 4,12 | — | — | — |
| 35 | 10,00 | 3,56 | 2,81 | — | — | — |
| 43 | 8,00 | 3,01 | 2,66 | — | — | — |

WH-UQ16HE8

| Tamb | CC | IP | EER | CC | IP | EER |
|------|-------|------|------|-------|------|------|
| LWC | 7 | 7 | 7 | 18 | 18 | 18 |
| 18 | 8,50 | 1,70 | 5,00 | 10,00 | 1,70 | 5,88 |
| 25 | 14,00 | 4,00 | 3,50 | 14,00 | 2,94 | 4,76 |
| 35 | 12,20 | 4,76 | 2,56 | 12,20 | 3,50 | 3,49 |
| 43 | 7,10 | 3,31 | 2,15 | 9,80 | 3,31 | 2,96 |

Tamb: Ambient Temperature (°C). LWC: Leaving Water Condenser Temperature (°C). HC: Heating Capacity (kW). CC: Cooling Capacity (kW). IP: Power Input (kW). This data is measured by Panasonic in accordance with EN14511-2 standard. This data is for reference purpose only, and does not guarantee the performance.

Aquaarea High Performance Mono-bloc H Generation Single Phase. Heating and Cooling - MDC • R410A refrigerant

WH-MDC05H3E5

| Tamb | HC | IP | COP | HC | IP | COP | HC | IP | COP | HC | IP | COP | HC | IP | COP | HC | IP | COP |
|------|------|------|------|------|------|------|------|------|------|------|------|------|------|------|------|------|------|------|
| LWC | 30 | 30 | 30 | 35 | 35 | 35 | 40 | 40 | 40 | 45 | 45 | 45 | 50 | 50 | 50 | 55 | 55 | 55 |
| -15 | 5,13 | 2,02 | 2,54 | 5,00 | 2,20 | 2,27 | 4,88 | 2,39 | 2,04 | 4,75 | 2,57 | 1,85 | 4,08 | 2,29 | 1,78 | 3,40 | 2,00 | 1,70 |
| -7 | 4,80 | 1,49 | 3,23 | 4,70 | 1,65 | 2,85 | 4,60 | 1,82 | 2,53 | 4,50 | 1,98 | 2,27 | 4,40 | 2,13 | 2,07 | 4,30 | 2,28 | 1,89 |
| 2 | 5,10 | 1,34 | 3,81 | 4,80 | 1,43 | 3,36 | 4,50 | 1,52 | 2,96 | 4,20 | 1,61 | 2,61 | 4,10 | 1,67 | 2,46 | 4,00 | 1,72 | 2,33 |
| 7 | 5,00 | 0,79 | 6,33 | 5,00 | 0,99 | 5,08 | 5,00 | 1,18 | 4,24 | 5,00 | 1,37 | 3,65 | 5,00 | 1,57 | 3,19 | 5,00 | 1,76 | 2,84 |
| 12 | 4,85 | 0,77 | 6,29 | 4,83 | 0,89 | 5,46 | 4,82 | 1,00 | 4,82 | 4,80 | 1,12 | 4,29 | 4,74 | 1,25 | 3,81 | 4,68 | 1,37 | 3,42 |

WH-MDC07H3E5

| Tamb | HC | IP | COP | HC | IP | COP | HC | IP | COP | HC | IP | COP | HC | IP | COP | HC | IP | COP |
|------|------|------|------|------|------|------|------|------|------|------|------|------|------|------|------|------|------|------|
| LWC | 30 | 30 | 30 | 35 | 35 | 35 | 40 | 40 | 40 | 45 | 45 | 45 | 50 | 50 | 50 | 55 | 55 | 55 |
| -15 | 4,60 | 1,68 | 2,75 | 4,60 | 1,89 | 2,43 | 4,60 | 2,11 | 2,19 | 4,60 | 2,32 | 1,98 | 4,55 | 2,56 | 1,78 | 4,50 | 2,79 | 1,61 |
| -7 | 5,60 | 1,88 | 2,99 | 5,50 | 2,04 | 2,70 | 5,40 | 2,21 | 2,45 | 5,30 | 2,37 | 2,24 | 5,15 | 2,56 | 2,01 | 5,00 | 2,75 | 1,82 |
| 2 | 6,65 | 1,79 | 3,73 | 6,60 | 2,00 | 3,30 | 6,55 | 2,22 | 2,96 | 6,50 | 2,43 | 2,67 | 6,40 | 2,64 | 2,43 | 6,30 | 2,84 | 2,22 |
| 7 | 7,00 | 1,33 | 5,28 | 7,00 | 1,55 | 4,52 | 7,00 | 1,78 | 3,94 | 7,00 | 2,00 | 3,50 | 7,00 | 2,24 | 3,13 | 7,00 | 2,47 | 2,83 |
| 12 | 7,00 | 1,30 | 5,38 | 7,00 | 1,45 | 4,83 | 7,05 | 1,65 | 4,27 | 7,10 | 1,90 | 3,74 | 7,15 | 2,10 | 3,40 | 7,20 | 2,30 | 3,13 |

WH-MDC09H3E5

| Tamb | HC | IP | COP | HC | IP | COP | HC | IP | COP | HC | IP | COP | HC | IP | COP | HC | IP | COP |
|------|------|------|------|------|------|------|------|------|------|------|------|------|------|------|------|------|------|------|
| LWC | 30 | 30 | 30 | 35 | 35 | 35 | 40 | 40 | 40 | 45 | 45 | 45 | 50 | 50 | 50 | 55 | 55 | 55 |
| -15 | 6,10 | 2,34 | 2,61 | 5,90 | 2,50 | 2,36 | 5,70 | 2,67 | 2,14 | 5,50 | 2,83 | 1,94 | 5,25 | 2,99 | 1,76 | 5,00 | 3,14 | 1,59 |
| -7 | 6,55 | 2,26 | 2,90 | 6,40 | 2,46 | 2,60 | 6,25 | 2,66 | 2,35 | 6,10 | 2,86 | 2,13 | 5,95 | 3,06 | 1,95 | 5,80 | 3,25 | 1,78 |
| 2 | 6,85 | 1,92 | 3,58 | 6,80 | 2,14 | 3,18 | 6,75 | 2,37 | 2,85 | 6,70 | 2,59 | 2,59 | 6,50 | 2,78 | 2,34 | 6,30 | 2,96 | 2,13 |
| 7 | 9,00 | 1,80 | 5,01 | 9,00 | 2,10 | 4,29 | 9,00 | 2,41 | 3,74 | 9,00 | 2,71 | 3,32 | 9,00 | 3,01 | 2,99 | 9,00 | 3,31 | 2,72 |
| 12 | 9,10 | 1,61 | 5,65 | 9,00 | 1,79 | 5,03 | 9,00 | 2,09 | 4,31 | 9,10 | 2,40 | 3,79 | 9,20 | 2,80 | 3,29 | 9,30 | 3,00 | 3,10 |

WH-MDC12H6E5

| Tamb | HC | IP | COP | HC | IP | COP | HC | IP | COP | HC | IP | COP | HC | IP | COP | HC | IP | COP |
|------|-------|------|------|-------|------|------|-------|------|------|-------|------|------|----|----|-----|-------|------|------|
| LWC | 30 | 30 | 30 | 35 | 35 | 35 | 40 | 40 | 40 | 45 | 45 | 45 | 50 | 50 | 50 | 55 | 55 | 55 |
| -15 | 9,30 | 3,46 | 2,69 | 8,90 | 3,62 | 2,46 | 8,50 | 3,79 | 2,24 | 8,10 | 3,95 | 2,05 | — | — | — | 7,00 | 4,10 | 1,71 |
| -7 | 10,40 | 3,37 | 3,09 | 10,00 | 3,66 | 2,73 | 9,60 | 3,95 | 2,43 | 9,20 | 4,24 | 2,17 | — | — | — | 8,20 | 4,21 | 1,95 |
| 2 | 11,80 | 3,10 | 3,81 | 11,40 | 3,31 | 3,44 | 11,00 | 3,53 | 3,12 | 10,60 | 3,74 | 2,83 | — | — | — | 9,10 | 4,08 | 2,23 |
| 7 | 12,00 | 2,10 | 5,71 | 12,00 | 2,53 | 4,74 | 12,00 | 2,96 | 4,05 | 12,00 | 3,39 | 3,54 | — | — | — | 12,00 | 4,10 | 2,93 |
| 12 | 12,00 | 1,38 | 8,70 | 12,00 | 1,66 | 7,23 | 11,80 | 1,94 | 6,08 | 11,70 | 2,23 | 5,25 | — | — | — | 11,40 | 2,74 | 4,16 |

WH-MDC16H6E5

| Tamb | HC | IP | COP | HC | IP | COP | HC | IP | COP | HC | IP | COP | HC | IP | COP | HC | IP | COP |
|------|-------|------|------|-------|------|------|-------|------|------|-------|------|------|-------|------|------|----|----|-----|
| LWC | 30 | 30 | 30 | 35 | 35 | 35 | 40 | 40 | 40 | 45 | 45 | 45 | 50 | 50 | 50 | 55 | 55 | 55 |
| -15 | 10,60 | 4,09 | 2,59 | 10,30 | 4,38 | 2,35 | 10,00 | 4,67 | 2,14 | 9,70 | 4,96 | 1,96 | 7,90 | 4,84 | 1,63 | — | — | — |
| -7 | 11,90 | 4,03 | 2,95 | 11,40 | 4,43 | 2,57 | 10,80 | 4,83 | 2,24 | 10,30 | 5,22 | 1,97 | 9,00 | 4,88 | 1,84 | — | — | — |
| 2 | 13,50 | 3,74 | 0,98 | 13,00 | 3,96 | 3,28 | 12,40 | 4,18 | 2,97 | 11,90 | 4,40 | 2,70 | 9,80 | 4,44 | 2,21 | — | — | — |
| 7 | 16,00 | 3,21 | 4,98 | 16,00 | 3,74 | 4,28 | 16,00 | 4,27 | 3,75 | 16,00 | 4,80 | 3,33 | 14,50 | 5,33 | 2,72 | — | — | — |
| 12 | 16,00 | 2,31 | 6,93 | 16,00 | 2,69 | 5,95 | 16,00 | 3,07 | 5,21 | 16,00 | 3,45 | 4,64 | 15,90 | 3,89 | 4,09 | — | — | — |

Tamb: Ambient Temperature (°C). LWC: Leaving Water Condenser Temperature (°C). HC: Heating Capacity (kW). CC: Cooling Capacity (kW). IP: Power Input (kW). This data is measured by Panasonic in accordance with EN14511-2 standard. This data is for reference purpose only, and does not guarantee the performance.

Heating & Cooling capacity tables

Based on outlet temperature and outside temperature.

Aquarea High Performance Mono-bloc H Generation Single Phase. Heating and Cooling - MDC • R410A refrigerant

| WH-MDC05H3E5 | | | | | | | | | |
|--------------|-------|------|------|-------|------|------|-------|------|------|
| Tamb | CC | IP | EER | CC | IP | EER | CC | IP | EER |
| LWC | 7 | 7 | 7 | 14 | 14 | 14 | 18 | 18 | 18 |
| 24 | 5,15 | 1,06 | 4,86 | 6,45 | 1,05 | 6,14 | 5,90 | 0,73 | 8,08 |
| 35 | 4,50 | 1,37 | 3,28 | 5,52 | 1,36 | 4,06 | 5,10 | 1,00 | 5,10 |
| 43 | 3,74 | 1,55 | 2,41 | 4,65 | 1,60 | 2,91 | 4,25 | 1,20 | 3,54 |
| WH-MDC07H3E5 | | | | | | | | | |
| Tamb | CC | IP | EER | CC | IP | EER | CC | IP | EER |
| LWC | 7 | 7 | 7 | 14 | 14 | 14 | 18 | 18 | 18 |
| 24 | 6,85 | 1,78 | 3,85 | 8,15 | 1,80 | 4,53 | 7,10 | 1,20 | 5,92 |
| 35 | 6,00 | 2,16 | 2,78 | 5,35 | 1,53 | 3,51 | 6,00 | 1,55 | 3,87 |
| 43 | 4,90 | 2,48 | 1,98 | 4,45 | 1,80 | 2,47 | 5,10 | 1,85 | 2,76 |
| WH-MDC09H3E5 | | | | | | | | | |
| Tamb | CC | IP | EER | CC | IP | EER | CC | IP | EER |
| LWC | 7 | 7 | 7 | 14 | 14 | 14 | 18 | 18 | 18 |
| 24 | 7,30 | 1,92 | 3,80 | 8,60 | 1,98 | 4,34 | 8,20 | 1,55 | 5,29 |
| 35 | 7,00 | 2,69 | 2,60 | 6,40 | 1,93 | 3,32 | 7,00 | 1,95 | 3,59 |
| 43 | 5,25 | 2,84 | 1,85 | 5,40 | 2,25 | 2,40 | 6,00 | 2,30 | 2,61 |
| WH-MDC12H6E5 | | | | | | | | | |
| Tamb | CC | IP | EER | CC | IP | EER | CC | IP | EER |
| LWC | 7 | 7 | 7 | 14 | 14 | 14 | 18 | 18 | 18 |
| 16 | 7,86 | 1,18 | 6,66 | 13,15 | 2,05 | 6,41 | 10,00 | 1,73 | 5,78 |
| 25 | 12,08 | 2,90 | 4,17 | 15,70 | 3,05 | 5,15 | 10,00 | 1,97 | 5,08 |
| 35 | 10,00 | 3,56 | 2,81 | 12,00 | 3,67 | 3,27 | 10,00 | 2,15 | 4,65 |
| 43 | 7,80 | 3,80 | 2,05 | 11,10 | 3,19 | 3,48 | 8,00 | 2,85 | 2,81 |
| WH-MDC16H6E5 | | | | | | | | | |
| Tamb | CC | IP | EER | CC | IP | EER | CC | IP | EER |
| LWC | 7 | 7 | 7 | 14 | 14 | 14 | 18 | 18 | 18 |
| 16 | 9,20 | 1,62 | 5,68 | 16,40 | 2,58 | 6,36 | 12,20 | 2,45 | 4,98 |
| 25 | 14,40 | 3,92 | 3,67 | 19,20 | 3,83 | 5,01 | 12,20 | 2,79 | 4,37 |
| 35 | 12,20 | 4,76 | 2,56 | 15,00 | 4,98 | 3,01 | 12,20 | 2,96 | 4,12 |
| 43 | 7,75 | 3,40 | 2,28 | 13,80 | 5,95 | 2,32 | 9,70 | 4,00 | 2,43 |

Tamb: Ambient Temperature (°C). LWC: Leaving Water Condenser Temperature (°C). HC: Heating Capacity (kW). CC: Cooling Capacity (kW). IP: Power Input (kW). This data is measured by Panasonic in accordance with EN14511-2 standard. This data is for reference purpose only, and does not guarantee the performance.

Aquaarea T-CAP Mono-bloc H Generation Single Phase / Three Phase. Heating and Cooling - MXC • R410A refrigerant

WH-MXC09H3E5 / WH-MXC09H3E8

| Tamb | HC | IP | COP | HC | IP | COP | HC | IP | COP | HC | IP | COP | HC | IP | COP | HC | IP | COP |
|------|-------|------|------|-------|------|------|-------|------|------|-------|------|------|-------|------|------|-------|------|------|
| LWC | 30 | 30 | 30 | 35 | 35 | 35 | 40 | 40 | 40 | 45 | 45 | 45 | 50 | 50 | 50 | 55 | 55 | 55 |
| -15 | 9,00 | 3,24 | 2,78 | 9,00 | 3,51 | 2,56 | 9,00 | 3,91 | 2,30 | 9,00 | 4,30 | 2,09 | 9,00 | 4,73 | 1,90 | 9,00 | 5,16 | 1,74 |
| -7 | 9,00 | 2,71 | 3,32 | 9,00 | 3,16 | 2,85 | 9,00 | 3,62 | 2,49 | 9,00 | 4,07 | 2,21 | 9,00 | 4,27 | 2,11 | 9,00 | 4,46 | 2,02 |
| 2 | 9,00 | 2,36 | 3,81 | 9,00 | 2,51 | 3,59 | 9,00 | 2,78 | 3,24 | 9,00 | 3,05 | 2,95 | 9,00 | 3,56 | 2,53 | 9,00 | 4,07 | 2,21 |
| 7 | 9,00 | 1,64 | 5,49 | 9,00 | 1,86 | 4,84 | 9,00 | 2,16 | 4,17 | 9,00 | 2,46 | 3,66 | 9,00 | 2,76 | 3,26 | 9,00 | 3,06 | 2,94 |
| 25 | 13,60 | 1,50 | 9,07 | 13,60 | 1,71 | 7,95 | 13,20 | 1,93 | 6,84 | 12,80 | 2,14 | 5,98 | 12,00 | 2,41 | 4,98 | 11,20 | 2,67 | 4,19 |

WH-MXC12H6E5

| Tamb | HC | IP | COP | HC | IP | COP | HC | IP | COP | HC | IP | COP | HC | IP | COP | HC | IP | COP |
|------|-------|------|------|-------|------|------|-------|------|------|-------|------|------|-------|------|------|-------|------|------|
| LWC | 30 | 30 | 30 | 35 | 35 | 35 | 40 | 40 | 40 | 45 | 45 | 45 | 50 | 50 | 50 | 55 | 55 | 55 |
| -15 | 12,00 | 4,75 | 2,53 | 12,00 | 4,96 | 2,42 | 12,00 | 5,41 | 2,22 | 11,00 | 5,38 | 2,04 | 10,80 | 5,82 | 1,86 | 10,50 | 6,26 | 1,68 |
| -7 | 12,00 | 3,85 | 3,12 | 12,00 | 4,41 | 2,72 | 12,00 | 4,98 | 2,41 | 12,00 | 5,54 | 2,17 | 12,00 | 5,90 | 2,03 | 12,00 | 6,26 | 1,92 |
| 2 | 12,00 | 3,19 | 3,76 | 12,00 | 3,49 | 3,44 | 12,00 | 3,87 | 3,10 | 12,00 | 4,25 | 2,82 | 12,00 | 4,86 | 2,47 | 12,00 | 5,47 | 2,19 |
| 7 | 12,00 | 2,18 | 5,50 | 12,00 | 2,53 | 4,74 | 12,00 | 2,96 | 4,05 | 12,00 | 3,39 | 3,54 | 12,00 | 3,78 | 3,17 | 12,00 | 4,16 | 2,88 |
| 25 | 13,60 | 1,55 | 8,77 | 13,60 | 1,76 | 7,73 | 13,40 | 2,10 | 6,38 | 13,20 | 2,43 | 5,43 | 12,60 | 2,66 | 4,74 | 12,00 | 2,89 | 4,15 |

WH-MXC12H9E8

| Tamb | HC | IP | COP | HC | IP | COP | HC | IP | COP | HC | IP | COP | HC | IP | COP | HC | IP | COP |
|------|-------|------|------|-------|------|------|-------|------|------|-------|------|------|-------|------|------|-------|------|------|
| LWC | 30 | 30 | 30 | 35 | 35 | 35 | 40 | 40 | 40 | 45 | 45 | 45 | 50 | 50 | 50 | 55 | 55 | 55 |
| -15 | 12,00 | 4,75 | 2,53 | 12,00 | 4,96 | 2,42 | 12,00 | 5,41 | 2,22 | 12,00 | 5,86 | 2,05 | 11,80 | 6,24 | 1,89 | 11,60 | 6,62 | 1,75 |
| -7 | 12,00 | 3,85 | 3,12 | 12,00 | 4,41 | 2,72 | 12,00 | 4,98 | 2,41 | 12,00 | 5,54 | 2,17 | 12,00 | 5,90 | 2,03 | 12,00 | 6,26 | 1,92 |
| 2 | 12,00 | 3,19 | 3,76 | 12,00 | 3,49 | 3,44 | 12,00 | 3,87 | 3,10 | 12,00 | 4,25 | 2,82 | 12,00 | 4,86 | 2,47 | 12,00 | 5,47 | 2,19 |
| 7 | 12,00 | 2,18 | 5,50 | 12,00 | 2,53 | 4,74 | 12,00 | 2,96 | 4,05 | 12,00 | 3,39 | 3,54 | 12,00 | 3,78 | 3,17 | 12,00 | 4,16 | 2,88 |
| 25 | 13,60 | 1,55 | 8,77 | 13,60 | 1,76 | 7,73 | 13,40 | 2,10 | 6,38 | 13,20 | 2,43 | 5,43 | 12,60 | 2,66 | 4,74 | 12,00 | 2,89 | 4,15 |

WH-MXC16H9E8

| Tamb | HC | IP | COP | HC | IP | COP | HC | IP | COP | HC | IP | COP | HC | IP | COP | HC | IP | COP |
|------|-------|------|------|-------|------|------|-------|------|------|-------|------|------|-------|------|------|-------|------|------|
| LWC | 30 | 30 | 30 | 35 | 35 | 35 | 40 | 40 | 40 | 45 | 45 | 45 | 50 | 50 | 50 | 55 | 55 | 55 |
| -15 | 16,00 | 6,30 | 2,54 | 16,00 | 6,89 | 2,32 | 16,00 | 7,45 | 2,15 | 16,00 | 8,10 | 1,98 | 16,00 | 8,48 | 1,89 | 15,20 | 8,96 | 1,70 |
| -7 | 16,00 | 5,85 | 2,74 | 16,00 | 6,42 | 2,49 | 16,00 | 7,00 | 2,29 | 16,00 | 7,57 | 2,11 | 16,00 | 8,10 | 1,98 | 16,00 | 8,62 | 1,86 |
| 2 | 16,00 | 4,67 | 3,43 | 16,00 | 5,21 | 3,07 | 16,00 | 5,74 | 2,79 | 16,00 | 6,31 | 2,54 | 16,00 | 6,90 | 2,32 | 16,00 | 7,50 | 2,13 |
| 7 | 16,00 | 3,35 | 4,78 | 16,00 | 3,74 | 4,28 | 16,00 | 4,30 | 3,72 | 16,00 | 4,80 | 3,33 | 16,00 | 5,43 | 2,95 | 16,00 | 5,91 | 2,71 |
| 16 | 16,00 | 2,59 | 6,18 | 16,00 | 3,18 | 5,03 | 16,00 | 3,71 | 4,31 | 16,00 | 4,27 | 3,75 | 16,00 | 4,86 | 3,29 | 16,00 | 5,22 | 3,07 |
| 25 | 16,00 | 2,02 | 7,92 | 16,00 | 2,58 | 6,20 | 16,00 | 2,91 | 5,50 | 16,00 | 3,36 | 4,76 | 16,00 | 3,74 | 4,28 | 16,00 | 4,00 | 4,00 |

Aquaarea T-CAP Mono-bloc H Generation Single Phase / Three Phase. Heating and Cooling - MXC • R410A refrigerant

| Models | WH-MXC09H3E5 | | | | | | | | | WH-MXC12H6E5 | | | | | | | | |
|--------|--------------|------|------|-------|------|------|--------------|------|------|--------------|------|------|--------------|------|------|-------|------|------|
| Tamb | CC | IP | EER | CC | IP | EER | CC | IP | EER | CC | IP | EER | CC | IP | EER | CC | IP | EER |
| LWC | 7 | 7 | 7 | 14 | 14 | 14 | 18 | 18 | 18 | 7 | 7 | 7 | 14 | 14 | 14 | 18 | 18 | 18 |
| 18 | 7,00 | 1,36 | 5,15 | 8,55 | 1,41 | 6,06 | 7,00 | 1,00 | 7,00 | 10,00 | 1,75 | 5,71 | 13,20 | 1,96 | 6,73 | 10,00 | 1,40 | 7,14 |
| 25 | 7,65 | 1,91 | 4,01 | 11,10 | 1,98 | 5,61 | 7,00 | 1,10 | 6,36 | 11,20 | 2,67 | 4,19 | 16,50 | 3,01 | 5,48 | 10,00 | 1,60 | 6,25 |
| 35 | 7,00 | 2,21 | 3,17 | 9,23 | 2,37 | 3,89 | 7,00 | 1,35 | 5,19 | 10,00 | 3,56 | 2,81 | 12,55 | 3,63 | 3,46 | 10,00 | 1,95 | 5,13 |
| 43 | 6,25 | 2,66 | 2,35 | 8,55 | 2,71 | 3,15 | 5,60 | 1,60 | 3,50 | 8,00 | 3,35 | 2,39 | 10,00 | 3,46 | 2,89 | 8,00 | 2,30 | 3,48 |
| Models | WH-MXC09H3E8 | | | | | | WH-MXC12H9E8 | | | | | | WH-MXC16H9E8 | | | | | |
| Tamb | CC | IP | EER | CC | IP | EER | CC | IP | EER | CC | IP | EER | CC | IP | EER | CC | IP | EER |
| LWC | 7 | 7 | 7 | 18 | 18 | 18 | 7 | 7 | 7 | 18 | 18 | 18 | 7 | 7 | 7 | 18 | 18 | 18 |
| 18 | 7,00 | 1,36 | 5,15 | — | — | — | 7,50 | 1,41 | 5,32 | — | — | — | 8,50 | 1,70 | 5,00 | 10,00 | 1,70 | 5,88 |
| 25 | 7,65 | 1,91 | 4,01 | — | — | — | 8,90 | 2,16 | 4,12 | — | — | — | 14,00 | 4,00 | 3,50 | 14,00 | 2,94 | 4,76 |
| 35 | 7,00 | 2,21 | 3,17 | — | — | — | 10,00 | 3,56 | 2,81 | — | — | — | 12,20 | 4,76 | 2,56 | 12,20 | 3,50 | 3,49 |
| 43 | 6,25 | 2,66 | 2,35 | — | — | — | 8,00 | 3,01 | 2,66 | — | — | — | 7,10 | 3,31 | 2,15 | 9,80 | 3,31 | 2,96 |

Tamb: Ambient Temperature [°C]. LWC: Leaving Water Condenser Temperature [°C]. HC: Heating Capacity [kW]. CC: Cooling Capacity [kW]. IP: Power Input [kW]. This data is measured by Panasonic in accordance with EN14511-2 standard. This data is for reference purpose only, and does not guarantee the performance.

Examples of installations

Aquarea J and H Generation:
Bivalent with buffer tank and mixing valve

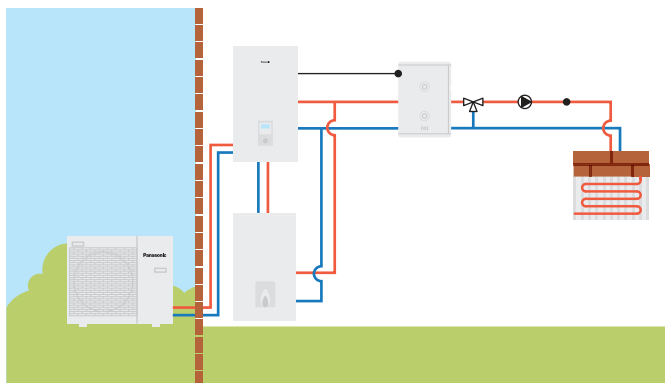

Aquarea J and H Generation:
Buffer tank with solar and mixing valve

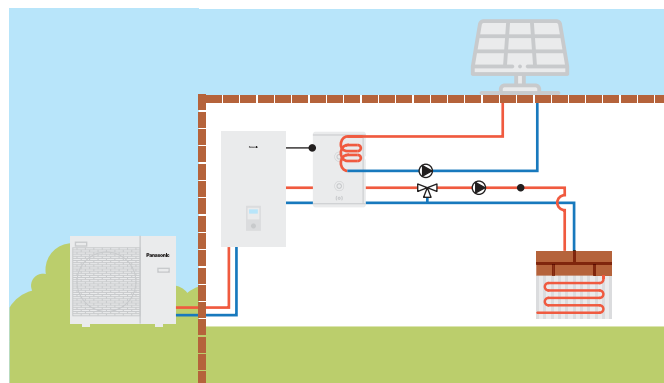

Aquarea J and H Generation:
2 zones with external kit without buffer tank

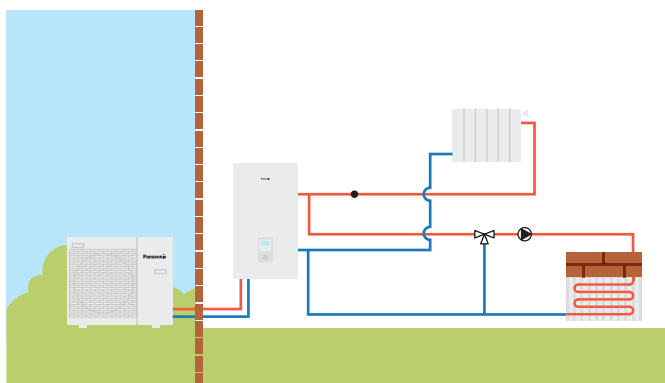

Aquarea J and H Generation:
2 zones with external kit, buffer tank and swimming pool

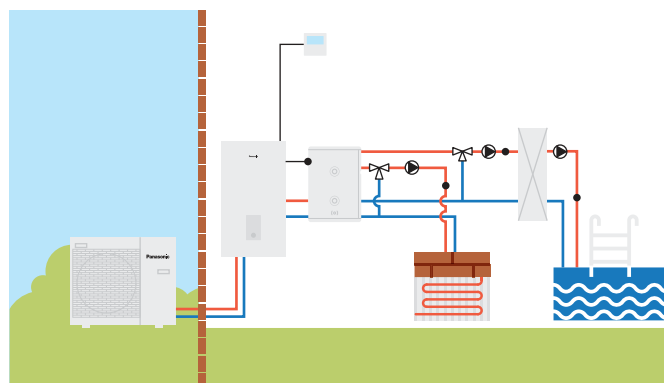

Aquarea All in One J and H Generation:
2 zones with external kit, without buffer tank

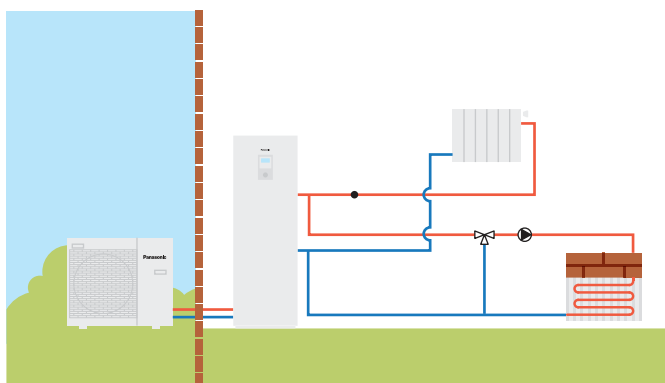

Aquarea All in One 2 zones J and H Generation:
2 zones built-in, without buffer tank

