

## Cooling. Heating. Innovation.

DK-Kälteanlagen manufactures components aimed at improving the performance balance of refrigeration cycles on the grounds of an active co-operation with numerous refrigeration companies. DK Heat-Recovery Systems and DK-Suction Gas Heat Exchangers allow customers of refrigeration companies to effectively save energy. The result: a minimisation of costs and less environmental pollution.

### **Our goal is to fulfil the different wishes of our customers.**

As a company, we are proud of the advice that we extend to our customers, as well as of our in-house production. This has enabled us for over thirty years to meet our customers' wishes by manufacturing customised solutions. In the past, these customer wishes have also proven to supply valuable suggestions, leading to the creation of the occasional new product.

This flexibility makes us a pioneer in the industry. We consider it our obligation to uphold this position for you. You may thus count on us to continuously advance our products and create new concepts for all of our customer groups in the future.

This catalogue provides information about the following DK products:

- DK - Heat Recovery**
- DK - Water Chiller**
- DK - Suction Gas Heat Exchanger**

### **DK-Kälteanlagen GmbH**

Hollefeldstraße 30 · 48282 Emsdetten · Tel.: 00 49 25 72 / 93 14-0 · Fax: 00 49 25 72 / 93 14-20  
Internet: [www.dk-kaelteanlagen.de](http://www.dk-kaelteanlagen.de) · E-Mail: [info@dk-kaelteanlagen.de](mailto:info@dk-kaelteanlagen.de)  
District court Steinfurt HRB 3729, VAT ID DE 812833295 · CEOs: Bernd Kappenberg, Michael Kappenberg

<b>Generalities Heat Recovery</b>	Certification Overview Example of use Description of materials
<b>Technical specification Heat Recovery internal heat exchangers</b>	Description of the Heat Exchanger Technical specification of the Heat Exchanger Arrangement of Heat Exchanger Installation options Pressure loss DK-Heat Recovery for CO <sub>2</sub> refrigerating plant New possibilities by a stainless steel heat exchanger
<b>Technical specification Heat Recovery external heat exchangers</b>	Description of the Heat Exchanger Technical specifications of the Heat Exchanger
<b>Dimensions Heat Recovery</b>	Technical drawing of the DK-Heat Recovery storage tanks DK buffer tanks with technical specifications
<b>Applications Heat Recovery</b>	Circuit proposals
<b>Special types</b>	DK-Heat Recovery Combi Tank A variety of possibilities for heating mains and/or heating water
<b>Suction Gas Heat Exchanger</b>	Description of the Suction Gas Heat Exchanger Technical specifications of the Suction Gas Heat Exchanger
<b>Generalities Water Cooling Systems</b>	Description of the Water Chiller Technical specifications of the Water Chiller
<b>Dimensions Water Cooling Systems</b>	Technical drawing of the DK-Water Chiller storage tanks DK cold water buffer tanks with technical specifications
<b>Applications Water Cooling Systems</b>	Circuit proposals
<b>Tender text</b>	
<b>Prices</b>	
<b>Additional information</b>	Data gathering for proposal preparation DK-Heat Recovery, DK-Water Chiller Spare parts Accessories: Cathode protection and dealing with legionella



Cooling. Heating.  
Innovation.

## Certification of DK-Products in the following countries

### Europe



### Germany



### Belgium



### Denmark



### Poland



### Switzerland



### Russia

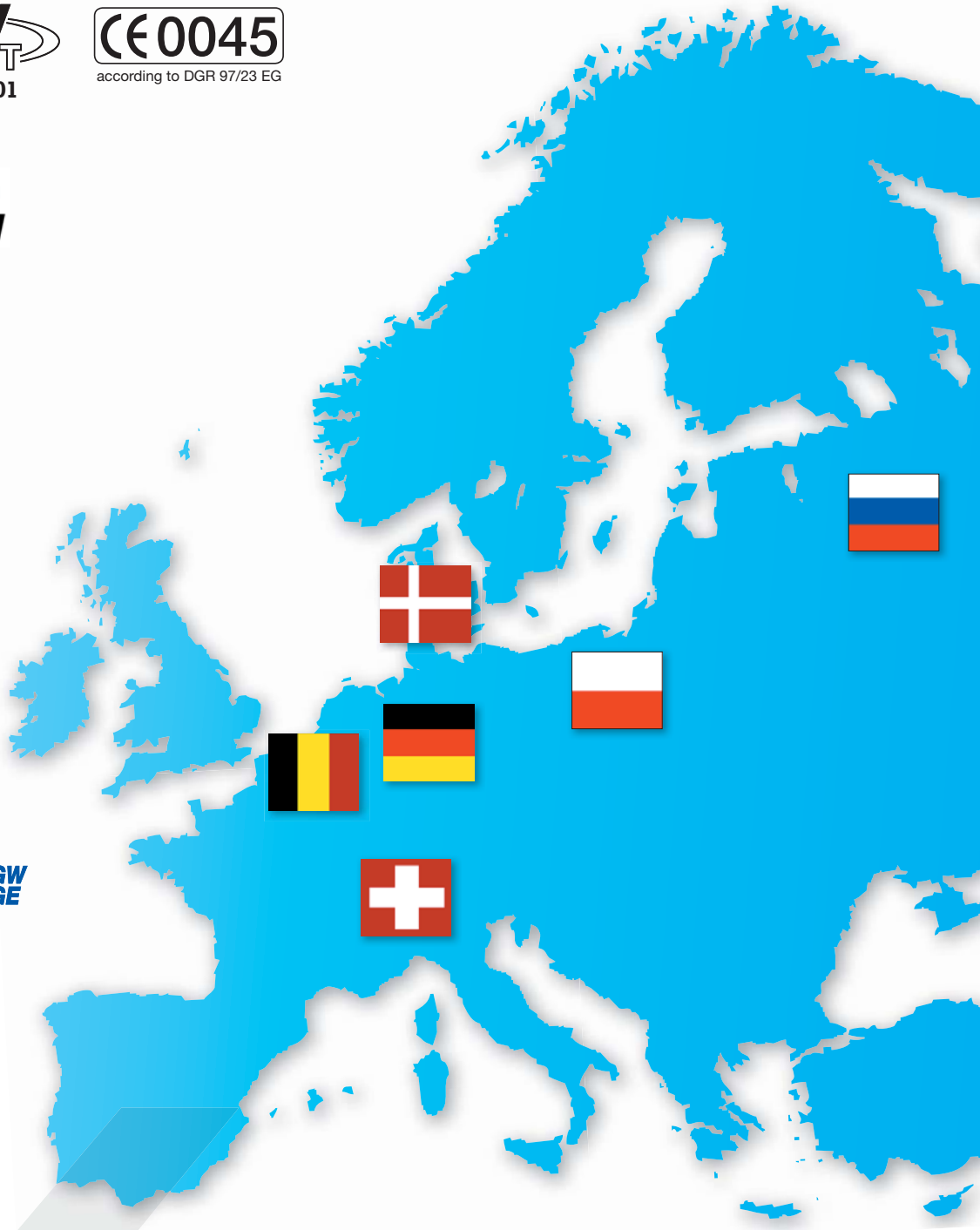



Cooling. Heating.  
Innovation.

## Energy Efficiency

Every business suffers from the substantial costs consumed for energy. Be sure to use valuable energy as wisely as possible. **DK-Heat Recovery Systems allow you to double the benefit gained from the energy you paid for!**

1. For your running refrigeration processes.
2. To heat potable water, to heat heating water or for the combined heating of potable and heating water (Combi Tank).

DK recommends that waste heat from the refrigeration units be primarily used to cover your needs for warm water. The simple reason for this:

**The need for warm water throughout the year is largely constant. For example, all food processing operations and food retailers can use the warm water for cleaning purposes. Heating, however, is only needed in winter.**

The DK-Heat Recovery System comes in two different designs: one with an internal heat exchanger, and the other with an external heat exchanger.



### DK-Heat Recovery with internal Heat Exchanger

The main area of application for the DK-Heat Recovery System with internal heat exchanger caters to individual refrigeration units (like restaurants, bakeries and butcher) or combined refrigeration systems with delivery pipes laid out for a max. 35 mm.

### DK-Heat Recovery with external Heat Exchanger

This type of plant is most appropriate if either a part (superheating) or the entire waste heat of a larger cooling plant is to be utilized.

Typical areas of application include supermarkets with combined low and medium temperature plants as well as the food processing industry.

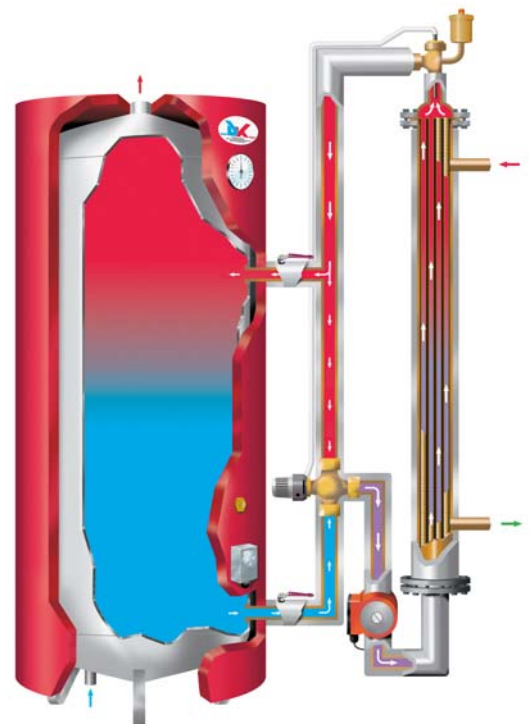



**Cooling. Heating.  
Innovation.**

## **Possible Applications**

Two obvious examples demonstrate just how very lucrative for small (café in the north of Germany) as well as larger refrigeration units (clinic in Duisburg) DK's heat recovery is. The following two pages exhibit two calculations of profitability which transparently showcase the advantages of the DK-Heat Recovery System

### **Café in the North of Germany**

The profitability analysis for the "Café in North Germany" demonstrates that periods of amortisation of around 2.5 years are customary, even for smaller refrigeration units.

### **Clinic in Duisburg**

When designing a DK-Heat Recovery System, is it not only the refrigeration units that must be taken into consideration. Of equal importance is the realistically estimated daily need of warm water. If neglected, there is a risk of over-sizing the DK-Heat Recovery System, entailing respectively high prices and unfavourable amortisation periods. The profitability calculation for the "Clinic Duisburg" clarifies this.

**You may request transparently-structured calculations of profitability such as these, at any time from DK, to demonstrate to your customer the costs they can save, the amortisation period for the unit, and the degree to which they reduce environmental pollution.**





## Example of use: Café in the north of Germany

### Café in the north of Germany

Walkin freezer	980 Watt
Cold storage cell	1,500 Watt
Refr. hold/beer	2,800 Watt
Counter	1,000 Watt
Refrigeration equipment kitchen	1,760 Watt
	<b>8,040 Watt</b>

### Data of installed DK-Heat Recovery System

1 x model 500/4 PU insulation
1 x plus nipple pair for 5th heat exchanger
1 x Correx Anode
4 x Heat Exchanger Model 16/10
1 x Heat Exchanger Model 18/12

**DK delivery: 2,860. - Euro**

**Cost of installation: approx. 4,500. - Euro**

Calculations of profitability for the offered DK-Heat Recovery

### Max. available warm water quantity:

$$\frac{8.04 \text{ kW} \times 3600 \text{ s/h} \times 0.85 (\eta \text{ efficiency})}{4.19 \text{ kJ/kgK} \times 45 \text{ K (heating from } 10 \text{ }^\circ\text{C to } 55 \text{ }^\circ\text{C)} \times 1000 \text{ kg/m}^3} = 130.5 \text{ (ltr./h)}$$

By a machine running time of 12 h/day

**the daily warm water quantity is 1566 l/day**

$$1500 \text{ l/day water consumption} = 1.5 \text{ m}^3/\text{day}$$

### annual warm water quantity

$$300 \text{ day/year} \times 1500 \text{ l/day} = \mathbf{450 \text{ m}^3/\text{year}}$$

### necessary energy per year:

By water warming from 10 °C to 55 °C the following energy is necessary:

$$\frac{450 \text{ m}^3/\text{year} \times 4.19 \text{ kJ/kgK} \times 45 \text{ K} \times 1000 \text{ kg/m}^3}{3600 \text{ s/h}} = 23569 \text{ kWh/year}$$

### Gas-Saving

With the DK-HEAT-RECOVERY the following gas quantity can be saved:

heating value of 1m<sup>3</sup> natural gas: 11.67 kWh/m<sup>3</sup>

η efficiency central gas heating for mains water warming: 0.75

$$\frac{23569 \text{ kWh/year}}{11.67 \text{ kWh/m}^3 \times 0.75} = 2693 \text{ m}^3 \text{ gas/saving per year}$$

**By gas price of 0.06 Euro/kWh there'll be a saving of 1886 Euro/year**

### Environment protection

With the DK-HEAT-RECOVERY you make an active contribution for reduce the CO<sub>2</sub> emission **4714 kg**

**CO<sub>2</sub> per year**

**Based on these figures, the amortization period amounts to 2.5 years, with CO<sub>2</sub> savings of 4714 kg CO<sub>2</sub>, which is a contribution towards protecting the environment.**



## Example of use: Duisburg Clinic

### Installed refrigeration units and DK Safety Heat Exchangers used

2 units combination-plus R404A to -10°C / tc 45°C  
Qo 2x 90 kW, discharge line 42 mm  
Desuperheater output 2x 28.3 kW x on-rating 0.6  
Effective deheater performance 2x 15,565 kW =  
31,35 kW

### Date of installed DK-Heat Recovery System

2,000 liter drinking water buffer  
2 units tubular desuperheater model 89/14x16/10 (1.6)  
1 pump 3-way valve model 47

**DK delivery: approx. 10,500.- Euro**

**Cost of installation: approx. 21,000. - Euro**

Dimensioning of the DK-Heat Recovery according to the actual requirement of warm water

Calculations of profitability for the offered DK-Heat Recovery

### available warm water quantity:

$$\frac{31.35 \text{ kW} \times 3600 \text{ s/h} \times 0.85 (\eta \text{ efficiency})}{4.19 \text{ kJ/kgK} \times 40 \text{ K (heating from } 10 \text{ }^\circ\text{C to } 50 \text{ }^\circ\text{C)} \times 1000 \text{ kg/m}^3} = 572.4 \text{ (litr./h)}$$

By a machine running time of 12 h/day  
the daily warm water quantity is 6869 l/day.

$$6000 \text{ l/day. water consumption} = 6 \text{ m}^3/\text{day}$$

### annual warm water quantity

$$360 \text{ day/year} \times 6000 \text{ ltr./day} = 2160 \text{ m}^3/\text{year}$$

### necessary energy per year:

By water warming from 10 °C to 50 °C the following energy is necessary:

$$\frac{2160 \text{ m}^3/\text{year} \times 4.19 \text{ kJ/kgK} \times 40 \text{ K} \times 1000 \text{ kg/m}^3}{3.600 \text{ s/h}} = 100560 \text{ kWh/Jahr}$$

### Gas-Saving

With the DK-HEAT-RECOVERY the following gas quantity can be saved:

heating value of 1m<sup>3</sup> natural gas: 11.67 kWh/m<sup>3</sup>

η, efficiency central gas heating for mains water warming: 0.75

$$\frac{100560 \text{ kWh/year}}{11.67 \text{ kWh/m}^3 \times 0.75} = 11489 \text{ m}^3 \text{ gas/saving per year}$$

**By gas price of 0.06 Euro/kWh there'll be a saving of 8045 Euro/year**

### Environment protection

With the DK-HEAT-RECOVERY you make an activ contribution for reduce the CO<sub>2</sub> emission

**20112 kg CO<sub>2</sub> per year.**

**Based on these figures, the amortization period amounts to 2.5 years, with CO<sub>2</sub> savings of 20112 kg CO<sub>2</sub>, which is a contribution towards protecting the environment.**



## Description of materials

### Storage tanks

#### For heating mains water:

Tanks out of steel for an operating pressure of 6 / 10 bar at max. + 95°C  
Corrosion protection by an emalled tank with cathode protection CORREX®-external current anode

#### For heat purposes

Tank out of steel for an operating pressure 2.5 bar at max. 95°C – inside raw

### Heat Exchanger

#### For heating mains water

Internal and external heat exchanger out of copper, double-walled safety designs according to EN 1717

#### For heat purposes

Internal and external heat exchanger out of copper, single-walled

### Isolation

#### Tubular heat exchanger, desuperheater, condenser

##### Kaiflex KK ®

Building material class: DIN 4102 B2, self-extinguishing as per ASTM D635-81  
Thermal conductivity  $\lambda$  (lamda): 0,04 W/mK bei +40°C  
Application range: -57°C up to +125°C

#### DK-Heat Recovery storage tank

##### DK flexible foam with PVC tissue case

Building material class: DIN 4102/B1  
Colour: RAL 2004, orange  
Thermal conductivity  $\lambda$  (lamda): 0,04 W/mK bei +40°C  
Application range: +20°C up to +95°C

#### DK-Heat Recovery storage tank

##### DK PU shells with glass fibre reinforced plastic hard shell s=55mm

Building material class: DIN 4102/B3  
Colour: RAL 2004, orange  
Thermal conductivity  $\lambda$  (lamda): 0,036 W/mK bei +0°C  
Application range: -20°C up to +105°C





Cooling. Heating.  
Innovation.

## DK-Heat Recovery with internal heat exchanger

### Throttle

for precision circulation volume in accordance with available condensation heat

### Permanent water circulation

through special counterflow heat exchangers

### Insulating riser tube

to transport heated water to top of vessel

### Heat exchanger case

strong-walled and insulating

### Displacement cylinder

inside the heat exchanger

### Finned tubular exchanger

with large surface

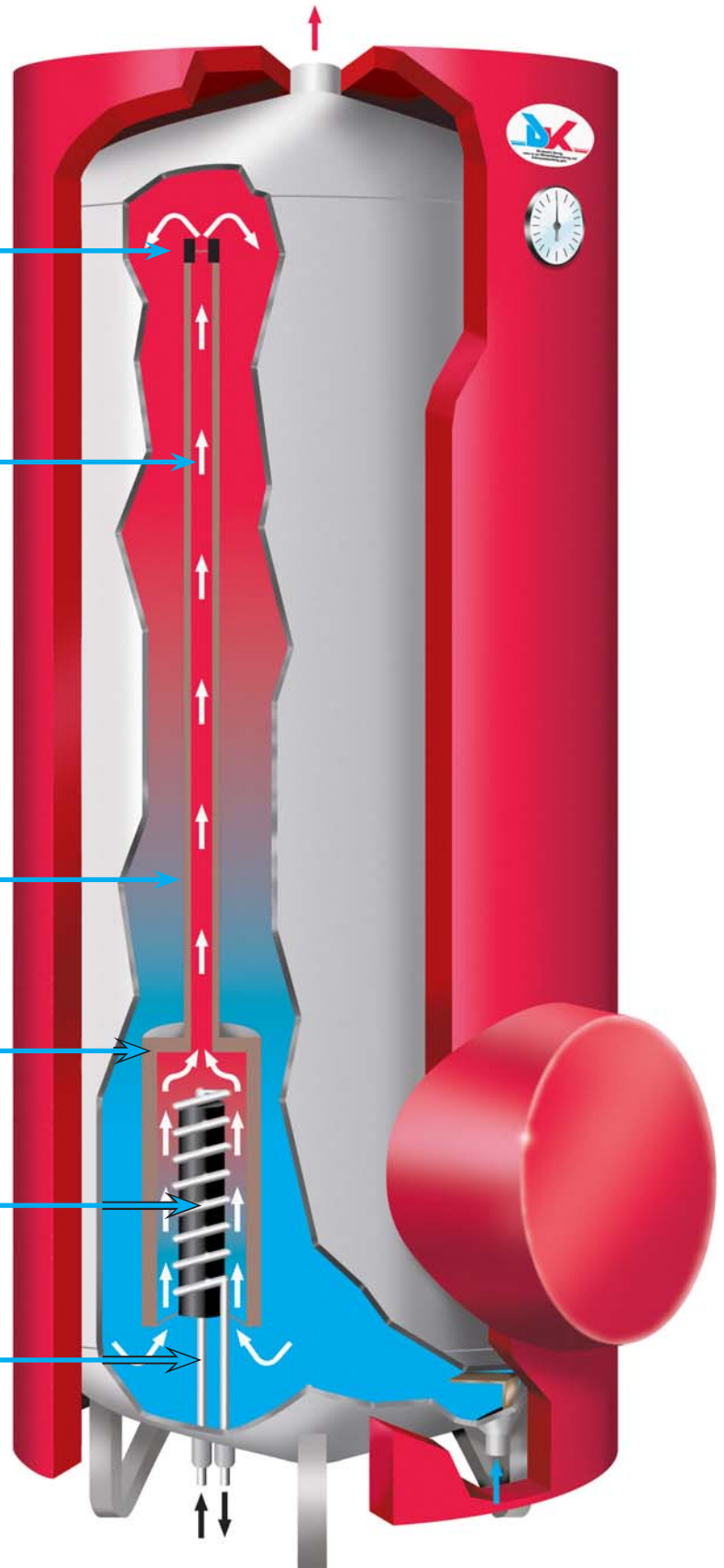

## Description of the Internal Heat Exchanger

The main area of application for the DK-Heat Recovery System with internal heat exchanger caters to individual refrigeration units or combined refrigeration systems with delivery pipes laid out for a max. 35 mm.

The requisite for the efficient operation of a DK-Heat Recovery unit with internal heat exchangers is the installation of the vessel with heat exchangers in the immediate vicinity to the refrigeration unit. The distance should not exceed 10 m.

The patented chimney principle of the heat exchanger helps to achieve highly accurate water layering inside the vessel. Since the water enters the heat exchanger in the vessel's cold water range, a longer period of operation is likely to produce a steady  $\Delta t_m$  value. This design accomplishes a much greater efficiency than when using heat exchangers placed freely inside the boiler.

The two following diagrams indicate  $\Delta t_m$  depending on the water temperature in the vessel for conventional systems as well as for the DK system.

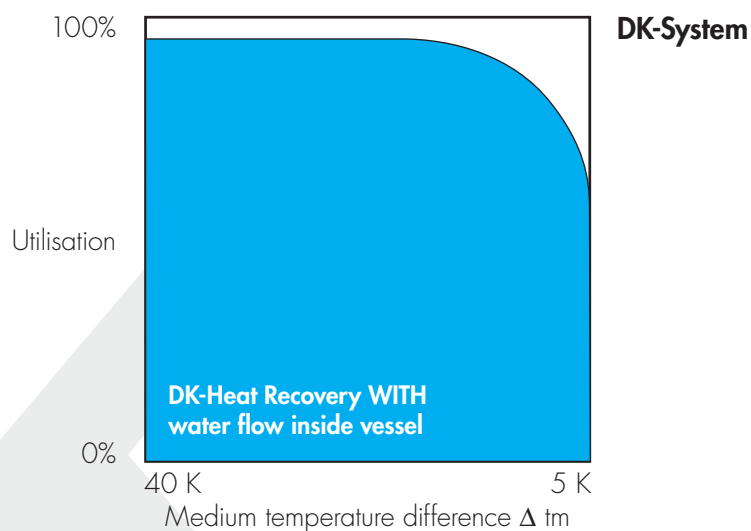
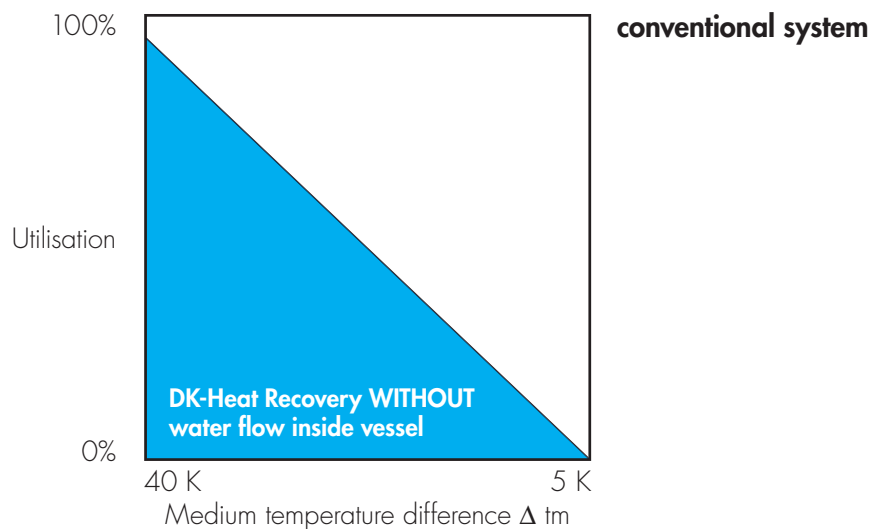



Important: **As a rule, all DK-Heat Exchangers for heating mains water are supplied as double-walled safety designs.**

The detailed drawing shows on the left side a pair of nipples with built-in heat exchanger and a capillary double-walled tube. The enlarged view of the right side illustrates the important details of the double walls of the heat exchangers.

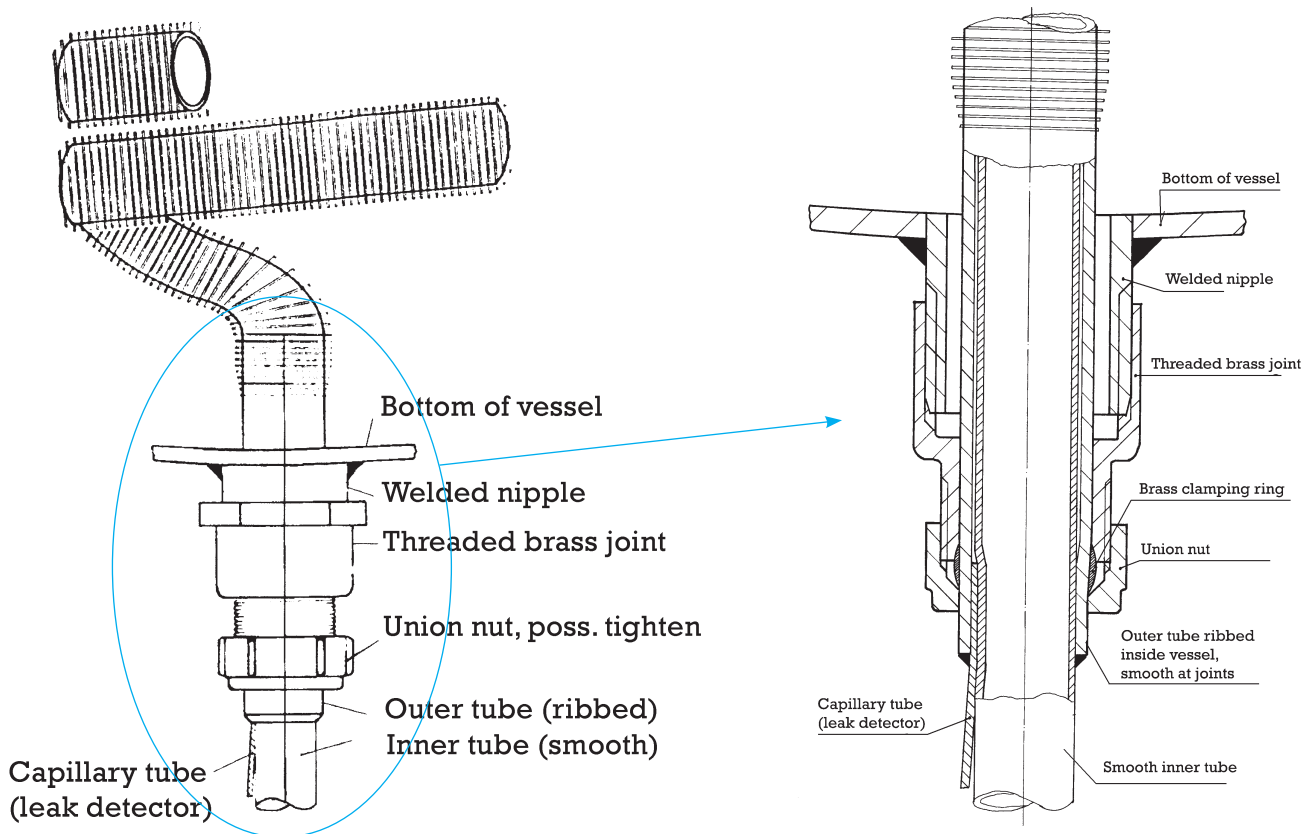

The 0.5 mm clearance between these two tubes accommodates a soldered capillary tube whose end features a safety valve.

In the event of a leak of the inner or outer tube, water or refrigerant will escape via the clearance of the capillary tube and safety valve. This capillary tube is then also used to fill the clearance between the inner and outer tube with a very low amount of a toxicologically harmless liquid heat medium. This ensures a good transition of heat. The contamination of the drinking water or an influx of water into the cooling cycle is thus prevented even in the case of a defect heat exchanger. The heat exchangers are sealed with a brass threaded clamping ring at the respective nipple to the bottom of the vessel. No rubber or Teflon gaskets are used which could become brittle after a while.



## Capacity information for double-walled safety heat exchangers

Heat exchanger capacity equals: surface x K-value x  $\Delta$  tm  
The maximum capacity is based on the following data:

Condensation temperature: (tc)	+55°C	+45°C
Water inlet temperature at heat exchanger:	+10°C	+15°C
Water outlet temperature at heat exchanger:	+50°C	+45°C
Average water temperature at heat exchanger: (tm)	+30°C	+30°C
$\Delta$ tm	25 K	15 K

k-value = 230 W/m<sup>2</sup> K

### Surfaces:

Type 16/10 = 0.8 m<sup>2</sup>      Type 18/12 = 1.2 m<sup>2</sup>      Type 22/16 (3,0) = 3.0 m<sup>2</sup>  
Type 22/16 = 2.0 m<sup>2</sup>      Type 28/20 = 3.0 m<sup>2</sup>

### This results in the following capacities for a $\Delta$ tm of 25 K:

Type 16/10: 0.8m<sup>2</sup> x 230m<sup>2</sup> x 25K = 4600 W      Type 18/12: 1.2m<sup>2</sup> x 230m<sup>2</sup> x 25K = 6900 W  
Type 22/16: 2.0m<sup>2</sup> x 230m<sup>2</sup> x 25K = 11500 W      Type 28/20: 3.0m<sup>2</sup> x 230m<sup>2</sup> x 25K = 17250 W  
Type 22/16 (3.0): 3.0m<sup>2</sup> x 230m<sup>2</sup> x 25K = 17250 W

### This results in the following capacities for a $\Delta$ tm of 15 K:

Type 16/10: 0.8m<sup>2</sup> x 230W/m<sup>2</sup> K x 15K = 2750W      Type 18/12: 1.2m<sup>2</sup> x 230 W/m<sup>2</sup> K x 15K = 4150W  
Type 22/16: 2.0m<sup>2</sup> x 230W/m<sup>2</sup> K x 15K = 6900W      Type 28/20: 3.0m<sup>2</sup> x 230 W/m<sup>2</sup> K x 15K = 10350W  
Type 22/16 (3.0): 3.0m<sup>2</sup> x 230W/m<sup>2</sup> K x 15K = 10350W

## DK Safety Counterflow Heat Exchanger (double-walled)

Exchanger	Weight (kg)	Inner tube	Refrigerant (dm <sup>3</sup> )	Surface (mm)	Capacity / W*
16/10 0.4m <sup>2</sup>	2.8	10x0.75	0.164	0.4	1500
16/10	5.2	10x0.75	0.312	0.8	3000
18/12	7.7	12x1	0.495	1.2	6000
22/16 1.0m <sup>2</sup>	6.6	16x1	0.615	1.0	6000
22/16 2.0m <sup>2</sup>	12.7	16x1	1.185	2.0	12000
22/16 3.0m <sup>2</sup>	18.5	16x1	1.815	3.0	18000
28/20 1.5m <sup>2</sup>	12.2	20x1	1.29	1.5	9000
28/20	22.6	20x1	2.39	3.0	18000

In line with internal heat exchangers, DK offers its finned coil tubing also for **external housings**. These heat exchangers are ideal for retrofitting if a vessel is already available. In addition, this concept convinces with its easy-maintenance options, as the housing is detachable.

## DK Counterflow Heat Exchanger (single-walled)

Exchanger	Weight (kg)	Inner tube inside (mm)	refrigerant (dm <sup>3</sup> )	Surface (mm)	Capacity / W*
16	3.6	10.5	0.389	0.8	2400
18	4.4	12.0	0.678	1.2	3600
22	9.0	16.0	1.909	2.5	7500
22/1	11.0	16.0	2.311	3.0	9000

\*  $\Delta$  tm 25K; k-value 230 W/m<sup>2</sup> x K



## Arrangement of Heat Exchanger

Upon request the heat exchanger connections can be located at specified sides.

### Example

- 1 x 22/16 in direction of A
- 1 x 18/12 in direction of B
- 1 x 16/10 in direction of C

### Top view

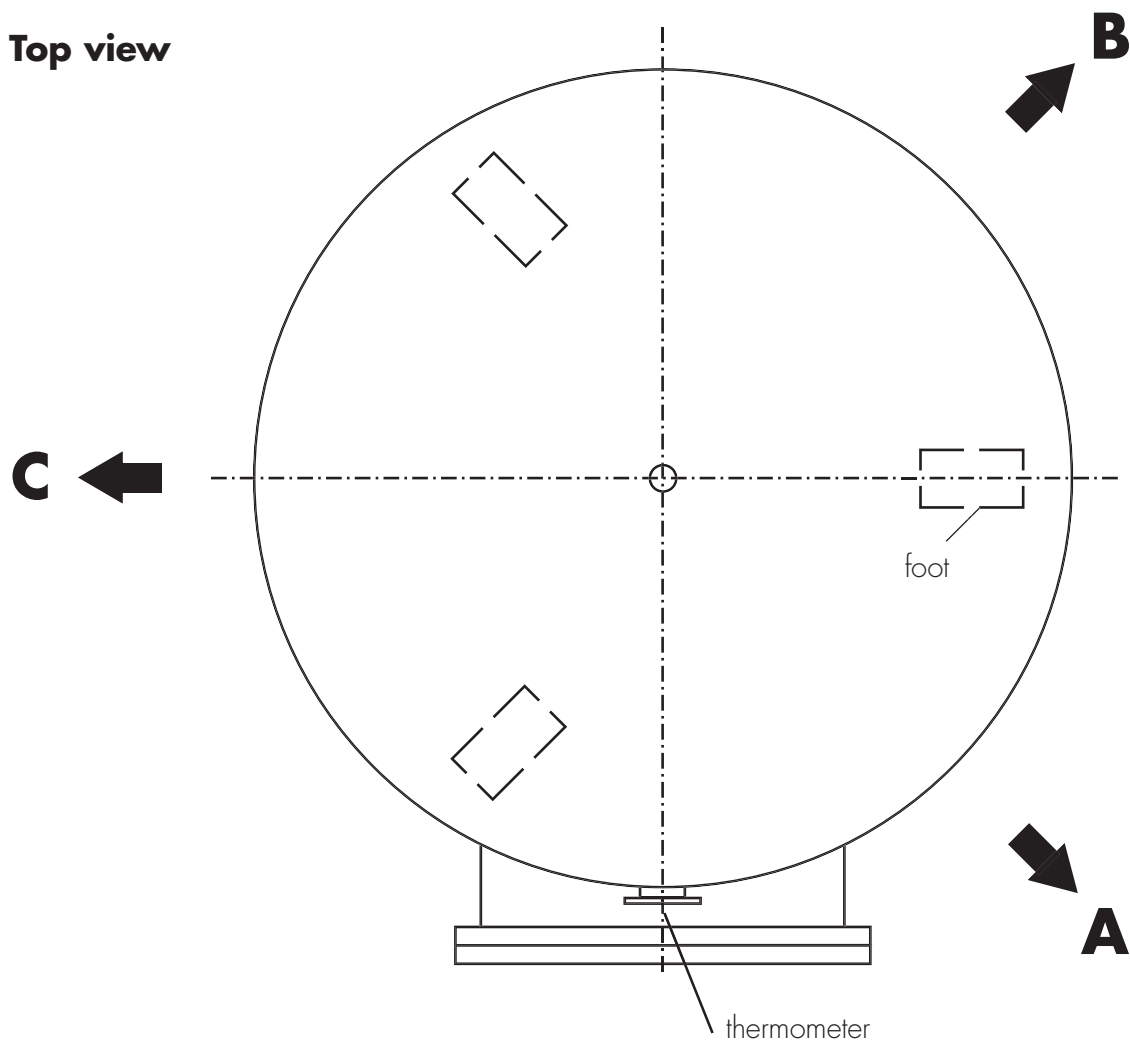



## Installation options

Standard vessel

### Model 200/1

Serial design	Customised design
1 heat exchanger 16/10 or 1 heat exchanger 18/12 or 1 heat exchanger 22/16 or 1 heat exchanger 28/20	4 heat exchangers 16/10 or 2 heat exchangers 18/12 or 2 heat exchangers 22/16

### Model 300/1 and 500/1

Serial design	Customised design
1 heat exchanger 16/10 or 1 heat exchanger 18/12 or 1 heat exchanger 22/16 or 1 heat exchanger 28/20	4 heat exchangers 16/10 or 2 heat exchangers 18/12 or 2 heat exchangers 22/16

### Model 300/4

Serial design	Customised design
4 heat exchangers 16/10 or 4 heat exchangers 18/12 or 4 heat exchangers 22/16	6 heat exchangers 16/10 or 5 heat exchangers 18/12 or 5 heat exchangers 22/16

### Model 500/4

Serial design	Customised design
4 heat exchangers 16/10 or 4 heat exchangers 18/12 or 4 heat exchangers 22/16	6 heat exchangers 16/10 or 5 heat exchangers 18/12 or 5 heat exchangers 22/16

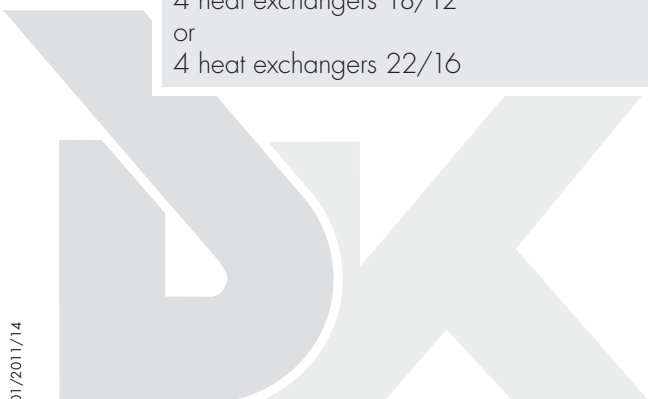



## Installation options

Standard vessel

### Model 750/5

Serial design	Customised design
4 heat exchangers up to 28/20 1 heat exchanger up to 22/16	8 heat exchangers 16/10 or 6 heat exchangers 18/12 or 6 heat exchangers 22/16

### Model 1000/5

Serial design	Customised design
4 heat exchangers up to 28/20 1 heat exchanger up to 22/16	8 heat exchangers 16/10 or 6 heat exchangers 18/12 or 6 heat exchangers 22/16

The aforementioned installation options are for refrigerant – heat exchangers, installed to the bottom of the vessel.

A further option is to build in an additional heat exchanger for a heating system as this is installed in the upper third of the vessel's jacket.  
(except for vessels of 200 and 300 lt.)





Cooling. Heating.  
Innovation.

## Dimension options for large vessels (standing reservoir)

Capacity	Diameter	Total height	max. number of heat exchangers to be installed
1,500 l	1,000 mm	2,200 mm	12 pcs
1,500 l	900 mm	2,500 mm	10 pcs
2,000 l	1,100 mm	2,400 mm	12 pcs
2,000 l	1,200 mm	2,000 mm	12 pcs
3,000 l	1,400 mm	2,350 mm	14 pcs
3,000 l	1,300 mm	3,550 mm	14 pcs
3,000 l	1,200 mm	2,800 mm	12 pcs
5,000 l	1,500 mm	3,200 mm	16 pcs
5,000 l	1,600 mm	2,850 mm	20 pcs
5,000 l	1,800 mm	2,300 mm	24 pcs
7,000 l	2,000 mm	2,600 mm	30 pcs
8,000 l	1,800 mm	3,400 mm	24 pcs
9,000 l	2,000 mm	3,300 mm	30 pcs
9,000 l	2,200 mm	3,000 mm	35 pcs

Further models upon request







## Pressure loss

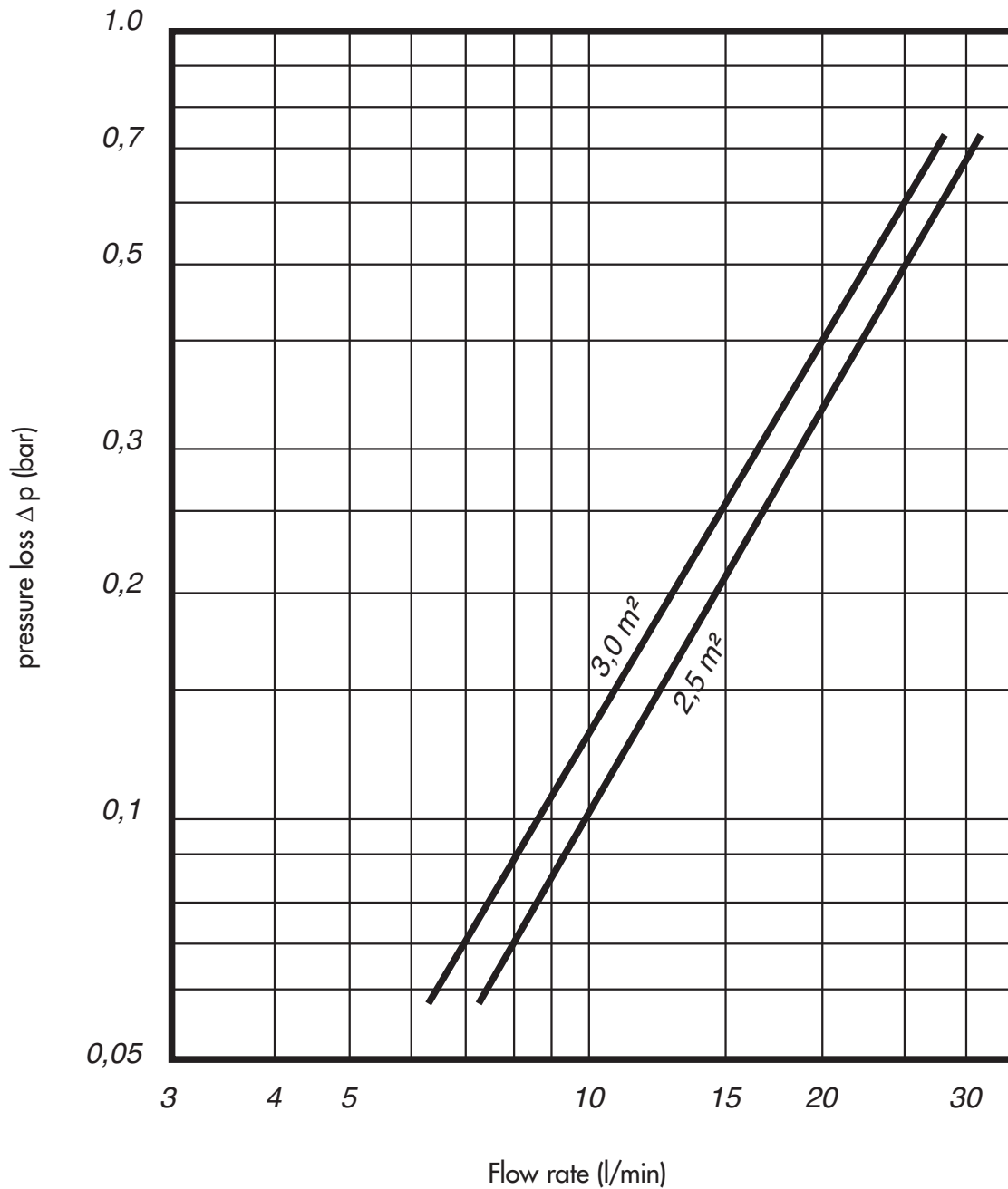

Diagram for pressure loss in heat exchanger 22 mm, 2.5 m<sup>2</sup> and 3.0m<sup>2</sup>



Cooling. Heating.  
Innovation.

## DK-Heat Recovery for CO<sub>2</sub> refrigerating plants in the transcritical range, max. 130 bar at max. +150 °C



DK-HEAT RECOVERY with internal safety heat exchangers

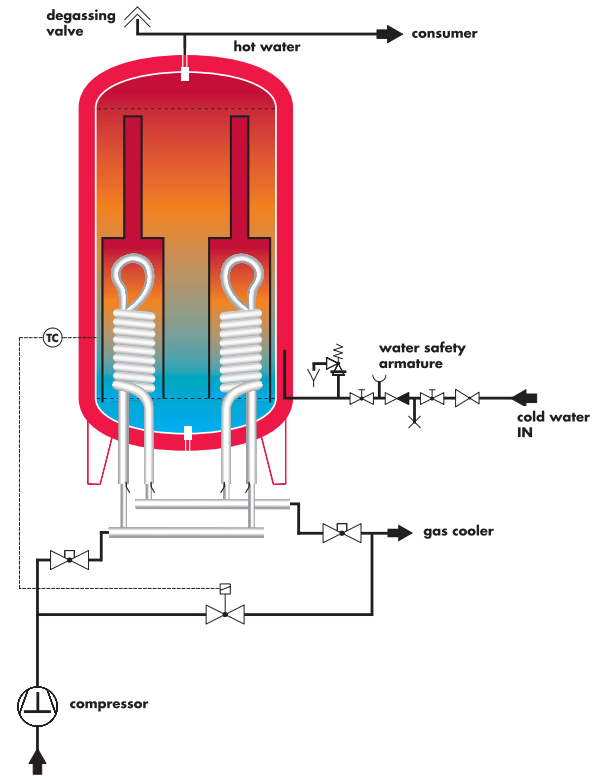

### Arrangement of Heat Exchanger in DK-Tank

Number of HE Type 22/16	Free cross section concerning the number of the heat exchangers	Inner diameter / Interconnection	Free cross section / Interconnection	Comparasation values R404A, t <sub>0</sub> -10/tc +42°C Q <sub>0</sub> /kW at 8 m/sec.	
2	207 mm <sup>2</sup>	16,0 mm	200 mm <sup>2</sup>	35 mm	60 kW
3	311 mm <sup>2</sup>	21,7 mm	369 mm <sup>2</sup>	42 mm	85 kW
4	415 mm <sup>2</sup>	24,0 mm	452 mm <sup>2</sup>	42-54 mm	110 kW
5	519 mm <sup>2</sup>	28,5 mm	637 mm <sup>2</sup>	54 mm	140 kW
6	622 mm <sup>2</sup>	28,5 mm	637 mm <sup>2</sup>	54 mm	140 kW

to install in DK storage tanks for internal heat exchanger

### Installation instructions

Due to high discharge temperatures of more than +100°C, steam may form inside the clear water reservoir if the capacity is insufficient and the consumption of water is too low. This must absolutely be avoided since the clear water reservoir is not designed as a steam drum.

The simplest solution is a change-over of the CO<sub>2</sub> refrigerant stream directly to the capacitor with an adequate temperature inside the clear water reservoir. In addition, a degassing valve is mounted at the clear water reservoirs or at **the external heat exchangers of the DK-Heat Recovery** for CO<sub>2</sub> operation which lets steam out, but remains closed for liquids. A suitable discharge pipe for water vapour or condensate should be provided on site. The optimal design of the heat recovery with respect to the size of the container and the actual warm water demand is the best way to prevent that compulsory measure.



Cooling. Heating.  
Innovation.

## Concept for the gastronomy



Since many years, the **DK-Heat Recovery** has been an inherent part within the refrigeration plants of numerous caterers. Such refrigeration plants use waste heat in order to heat a large part of the daily drinking water demand.

### **An additional component was added to this proven concept:**

In the case of the DK-Heat Recovery, an enamelled tank (thermo-glaze) has been used for many years. This container is chemically neutral and offers ideal hygienic conditions. The heat exchangers are made of copper which is the most commonly used material in refrigerating plants and which offers a good heat transfer. For deionised water, other materials are required.

For being used with dishwashers, we succeeded in integrating an additional stainless steel spiral tube heat exchanger into the heat recovery container. The heat transfer capacity of such a heat exchanger amounts to approx. 20 kW. Through the interconnection of several heat exchangers, an even higher efficiency can be obtained.





Cooling. Heating.  
Innovation.

## DK-Heat Recovery with external heat exchanger / tubular heat exchanger

### Vessel

Vessel for drinking water – special vessel enamel  
Vessel for heating water – unenamelled  
insulation PU foam, soft foam or PVC

### Desuperheater

Double-walled design for drinking water  
Single-walled for heating water

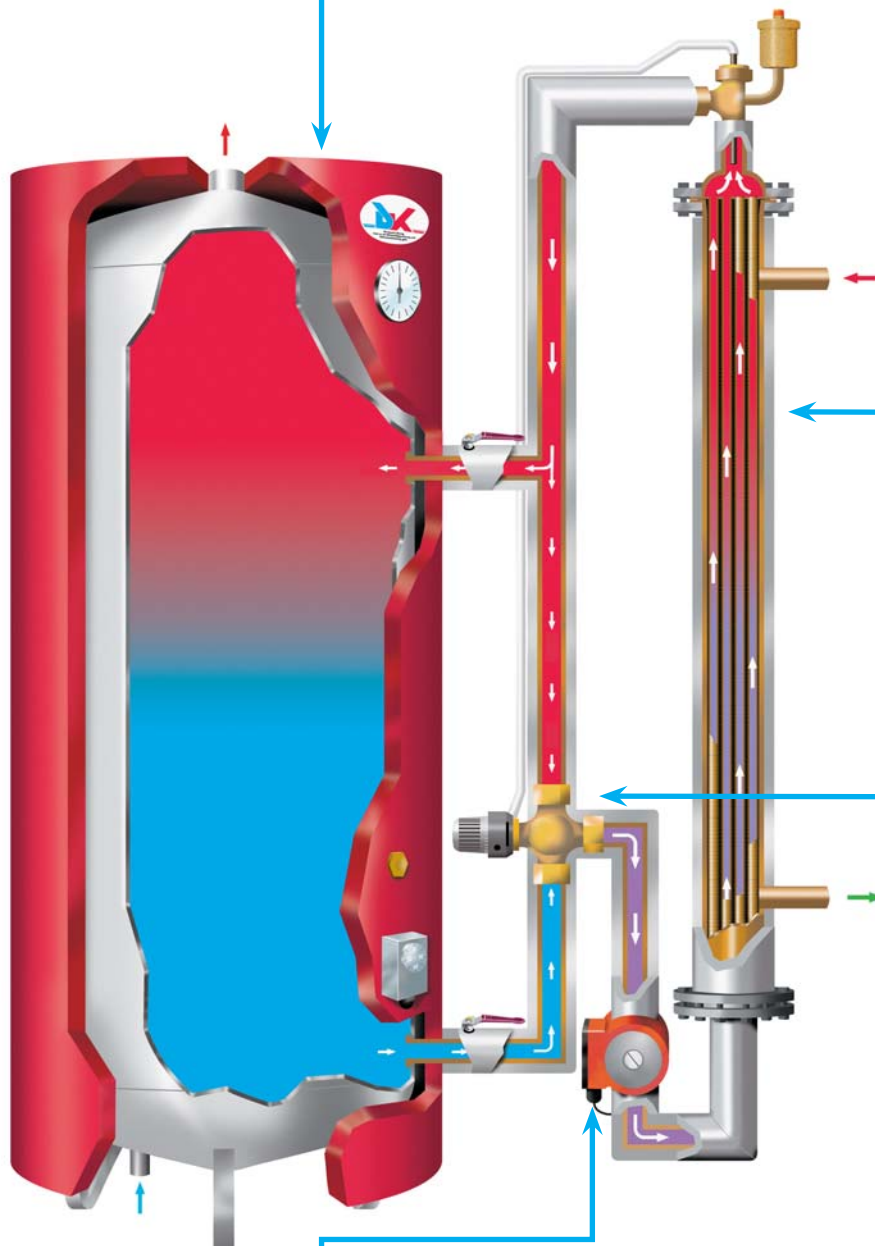

### Charge pump

For continues water-flow and to charge vessel

### 3-way-valve

For efficient buffer-charging with high temperatures



## Description of the External Heat Exchanger

The main area of application for DK-Heat Recovery Systems with external heat exchangers refers to larger combined installations with delivery pipes of up to 108 mm.

The heat exchangers can be attached directly to the vessel as shown in the picture, or are available separately for installation in combined units, should the vessels be set up at a distance. Moreover, external heat exchangers can also be used for already existing vessels with the respective supply line connections.

**A further important note: The DK-Heat Recovery with external heat exchangers also facilitates a separation between refrigeration and sanitary without difficulties. This is a frequent requirement of supermarket properties.**

In many cases the vessel with the pump and the water carrying regulation is added to the building and thus to the client, and the operator of the market is only charged with the heat exchanger (component of refrigeration unit). The following illustrations demonstrate different wiring proposals when separating into sanitary and refrigeration segments.

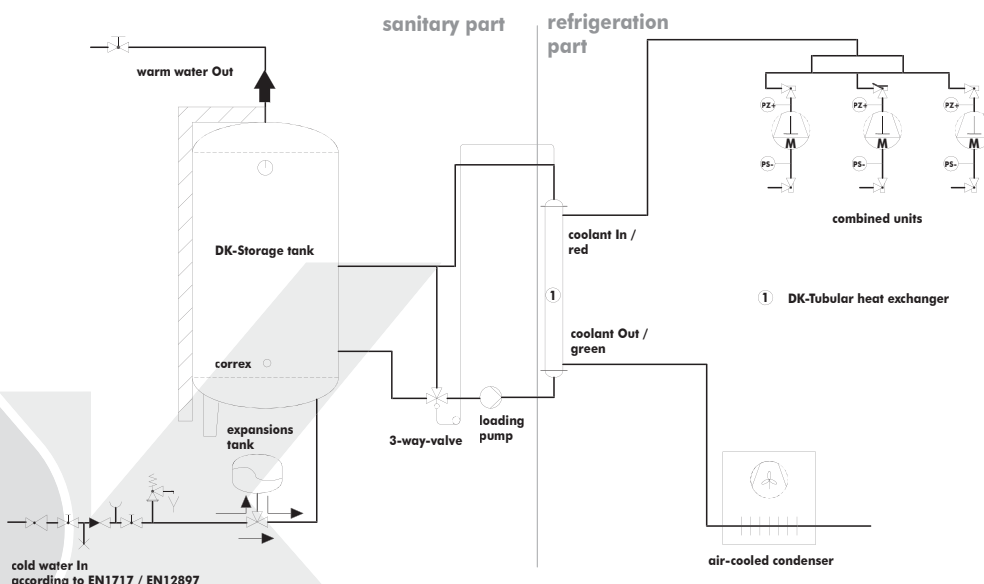
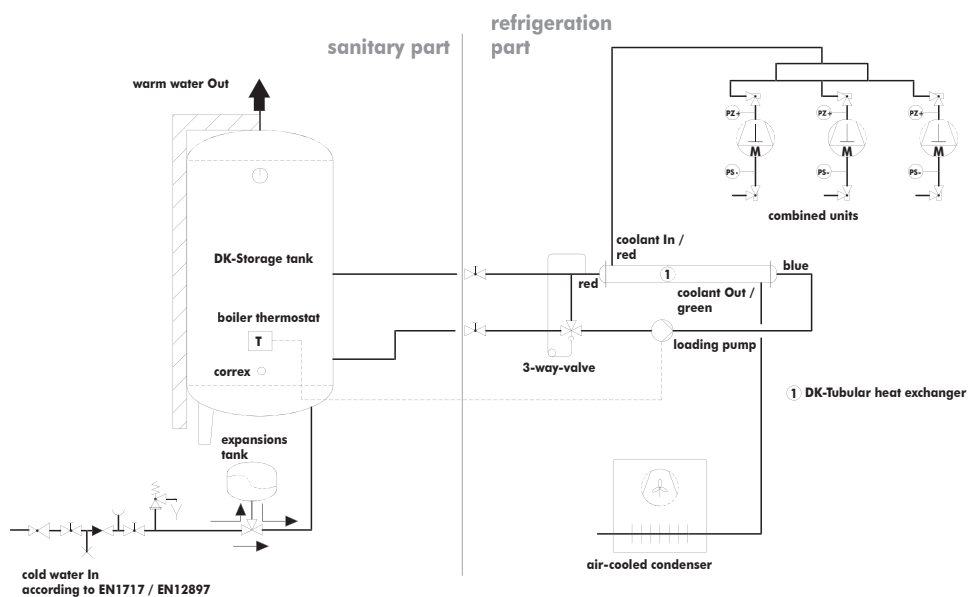



The double-walled external heat exchanger of DK-Heat Recovery Systems comes in nine different basic types, in increments of 0.1 m, so that a suitable heat exchanger can be calculated for any area of application.

Double-walled heat exchangers of the DK-Heat Recovery system can be calculated as tubular deheaters or even as tubular condensers. For supermarkets, the exclusive use as a deheater suffices, whereas in the meat industry the condensation heat should also be used.

For these cases the so-called tubular condenser unit has proven ideal, whereby the entire desuperheating capacity and the same quantity condensing capacity is used. A higher water temperature and sufficient amount of warm water can be reached directly, e.g. heating the water from +10 to +60°C:

- a) Pre-heating from +10 to +35°C with part condensing capacity
- b) After-heating from +35 to +60°C with desuperheating capacity

**DK-Tubular Desuperheaters and DK-Tubular Condensers as a rule are supplied as a double-walled safety design to warm up potable water.** The illustration shows the double-walled design: Refrigerant in the jacket/water in the inner tubes. Safety collection chamber are to both sides of the vessel with safety pressure relief valve.

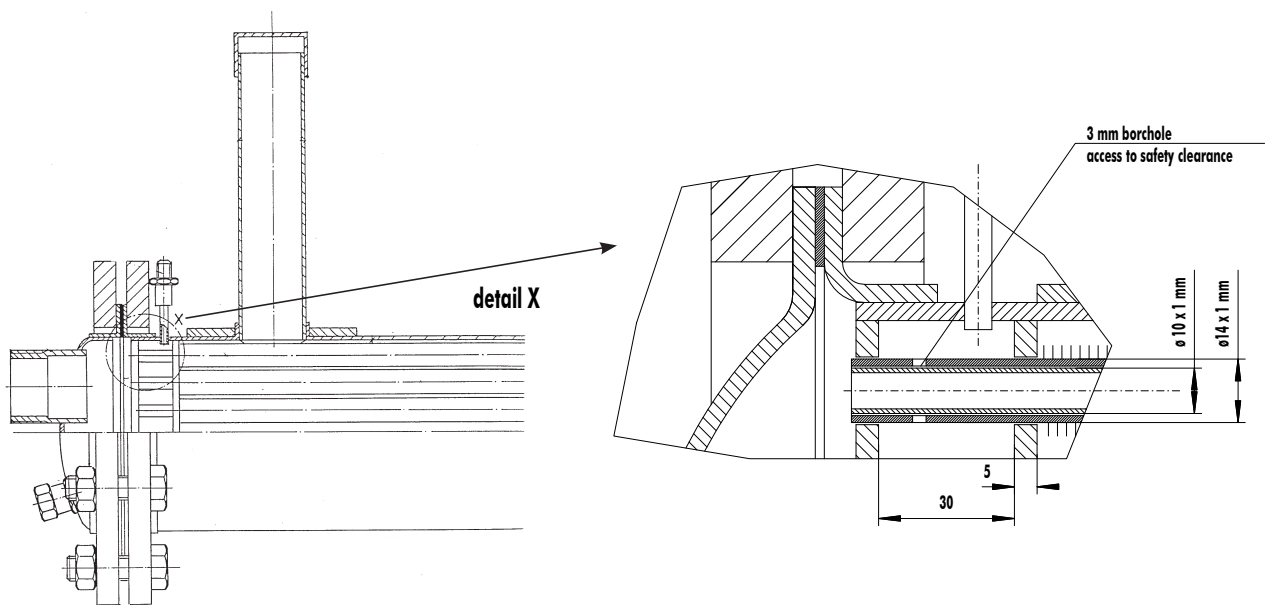

**DK-Tubular Desuperheaters /Tubular Condensers** tend to be calculated for the full desuperheating capacity or condensing capacity of a combination installation. The heat exchanger is over-dimensioned for the partial load segment. During a constant flow rate of the pump the partial load segment of the refrigeration unit uses the full amount of energy, but produces lower water OUT temperatures so that any already created warm water cushion could blend in the vessel with colder water. To avoid this, we offer for external heat exchangers of combination refrigeration units thermally-controlled 3-way valves. **With the DK technology thus ensures that even the partial load segment is supplied with a steady high water temperature to the buffer.**

A further advantage of the 3-way valve consists in preventing the condensation during partial load operation while exclusively using the superheating.

The same design of the double-walled tubular desuperheaters / tubular condensers is also available for NH<sub>3</sub> refrigerants, whereby all water-carrying parts are made of stainless steel and the refrigerant-carrying parts are produced from ST 35 steel.



**Cooling. Heating.  
Innovation.**

## DK-Tubular Desuperheater and Condenser, double-walled

Copper laced pipe with finned tubes housed in copper piping, complete with mounting supports and insulation

Type	External pipe (mm)	Internal tubes	Clear surface area of water (mm <sup>2</sup> )	Water connection max. (")	Clear surface area refrigerant (mm <sup>2</sup> )	Refrigerant connection max. (mm)	Surface area of refrigerant (m <sup>2</sup> /m)	Weight (kg/m)	Weight (kg per 0.1m)	Total length: calculated length of finned tubes plus
42/2 x 16/10	42	2 x 16/10	113	½	536	28	0.38	17	1	0.2
54/4 x 16/10	54	4 x 16/10	226	¾	768	35	0.76	22	1	0.2
64/7 x 16/10	64	7 x 16/10	397	1	733	35	1.33	30	2	0.2
76/10 x 16/10	76	10 x 16/10	567	1	1,089	42	1.90	35	2	0.3
89/14 x 16/10	89	14 x 16/10	794	1¼	1,360	42	2.66	45	3	0.3
108/21 x 16/10	108	21 x 16/10	1,190	1½	2,526	54	3.99	60	4	0.3
133/28 x 16/10	133	28 x 16/10	1,588	1½	4,105	76	5.32	80	5	0.3
159/38 x 16/10	159	38 x 16/10	2,153	2	6,796	76	7.22	95	7	0.4
219/64 x 16/10	219	64 x 16/10	3,584	2½	15,191	108	12.16	170	10	0.4

## DK-Tubular Desuperheater and Condenser, single-walled

Copper laced pipe with finned tubes housed in copper piping, complete with mounting supports and insulation

Type	External pipe (mm)	Internal tubes	Clear surface area of water (mm <sup>2</sup> )	Water connection max. (")	Clear surface area refrigerant (mm <sup>2</sup> )	Refrigerant connection max. (mm)	Surface area of refrigerant (m <sup>2</sup> /m)	Weight (kg/m)	Weight (kg per 0.1m)	Total length: calculated length of finned tubes plus
42/4 x 13	42	4 x 13	177	½	278	22	0.64	17	0.5	0.2
54/7 x 13	54	7 x 13	309	1	466	28	1.12	22	1	0.2
64/10 x 13	64	10 x 13	441	1	689	35	1.6	30	2	0.3
76/15 x 13	76	15 x 13	662	1¼	864	35	2.40	35	3	0.3
89/20 x 13	89	20 x 13	883	1½	1,398	42	3.2	45	3	0.3
108/30 x 13	108	30 x 13	1,324	1½	1,950	54	4.8	60	4	0.3
133/37 x 13	133	37 x 13	1,634	1½	4,555	76	5.92	80	5	0.3
159/50 x 13	159	50 x 13	2,200	2	7,691	76	8.0	95	6	0.4
219/85 x 13	219	85 x 13	3,740	3	16,130	108	13.6	170	7	0.4



Cooling. Heating.  
Innovation.

## DK-Heat Recovery Combi-Tank

With internal and / or external heat exchanger out of copper  
and spiral tube heat exchanger out of stainless steel

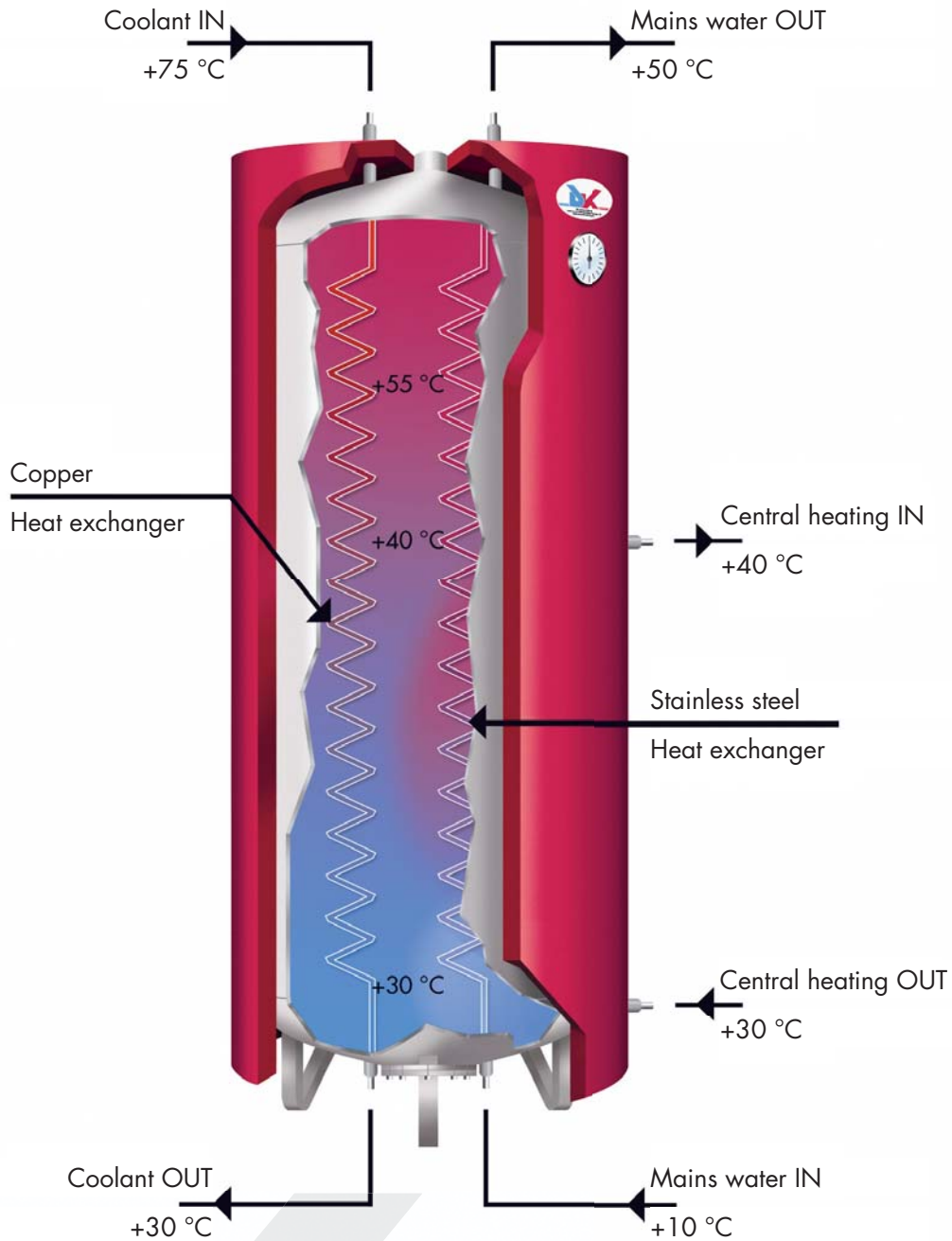





**Cooling. Heating.  
Innovation.**

## Combi-Tank

Traditionally, the DK-Heat Recovery has mainly been used for the purpose of heating drinking water, since most end customers need large amounts of warm water every day, for example for cleaning purposes. This warm water is required in even quantities over the entire year, leading to the best efficiency with respect to heat recovery. This is the decisive difference compared with heat recovery for heating purposes, which is used over half the year at the most.

**However, there are customers who only use the desuperheating for heating mains water, so that the condensation heat is available for heating purposes for example in a supermarket. For this application, DK can offer different combination systems. Heating water is warmed in a basin and drinking water is heated by means of an additional stainless steel spiral tube in the same basin in a continuous flow process.**

For these combination systems, DK uses raw heating basins with single-walled heat exchangers. Two walls are provided between refrigerant and drinking water in compliance with EN 1717. Preferably, the heating water feed is arranged at a height of two thirds of the basin, so that there is a hot water „cushion“ at the top of the basin which is not cooled by the system water circuit. The upper part of the basin is heated by the heating warmth of the refrigerant to temperatures above condensation temperature. Thus, the drinking water can be heated to a temperature exceeding the condensation temperature. The heating of the basin can be carried out using internal or external heat exchangers.

In order to ensure both of the aforementioned water temperatures inside the tank are obtained, the special use of the desuperheat is particularly necessary. Internal heat exchangers are run across the entire basin height; in the case of external heat exchangers, the desuperheater and the condenser must be separated.

**This system is also suitable for large containers so that there is sufficient energy in, for example, a 5000 l container for a huge amount of water. In the case of an increased warm water demand, several stainless steel spiral tubes can be connected in parallel. The thermal output of a stainless steel spiral tube amounts to approximately 20 kW.**

## New concepts for supermarkets and discounter

Let us now introduce three new DK concepts with the help of technical schemes. These drawings are understood to be an inspiration. Many other systems are possible and - of course - efficient, too. DK is always prepared to identify the suitable system for you.





## Concepts for supermarkets Heating with commercial refrigeration

### → Possibility of total heating with a heat pump

The drawing shows a DK-Heat Recovery unit for the heating of a discount store using the waste heat of the commercial refrigeration without warm water heating. Using the additional air / water heat pump a sufficient amount of heating water for the heating during the winter and of cold water for air-conditioning during the summer can be made available.

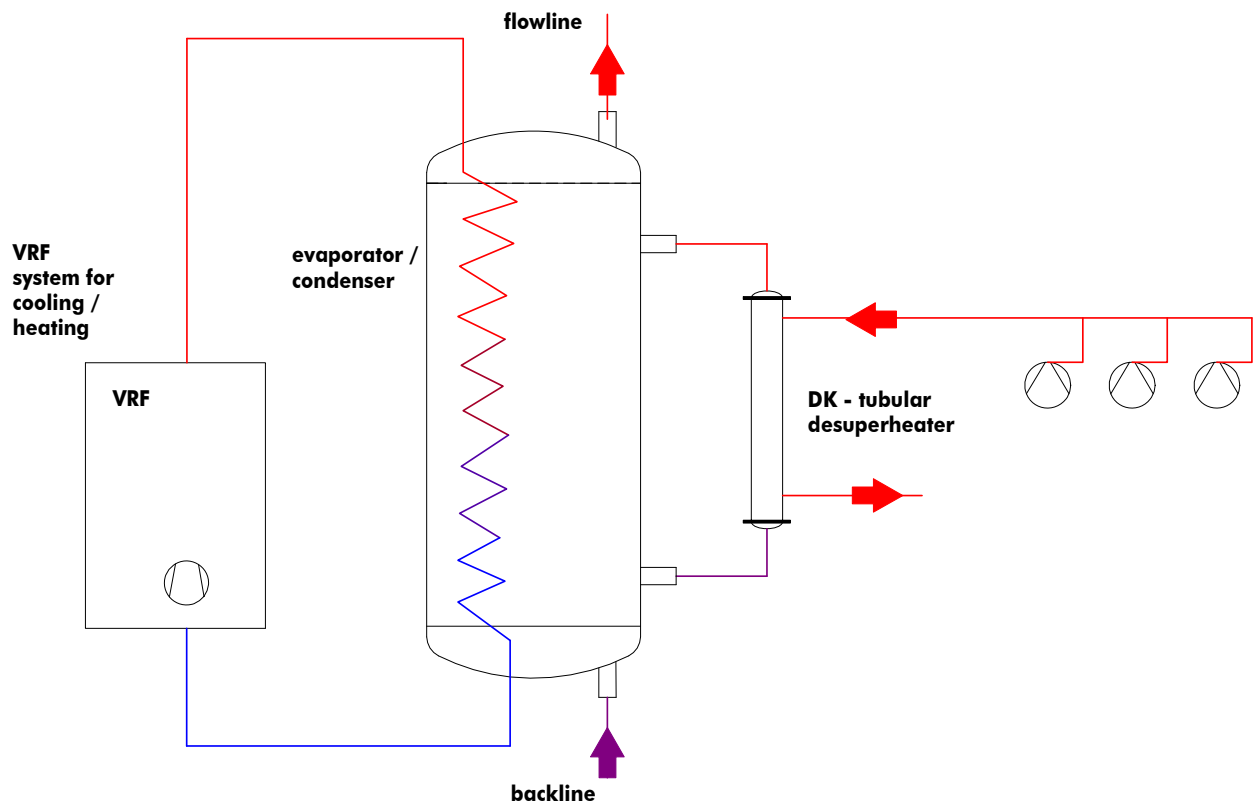



## Concepts for supermarkets Heating with commercial refrigeration

- Possibility of a heat exchanger for mains water warming
- Possibility of total heating with a heat pump

This wiring diagram shows how the waste heat of the combined unit is used by a single-walled Tubular Condenser in a heating reservoir. Using an additional Tubular Desuperheater, the upper part of the reservoir is heated with the desuperheating capacity to a temperature level exceeding condensing temperature.

In addition, a condenser can be installed for an air-water-heat pump, in order to heat the entire supermarket. A stainless steel spiral tube is installed in this heating reservoir which ensures the required amount of warm water is provided to the supermarket.

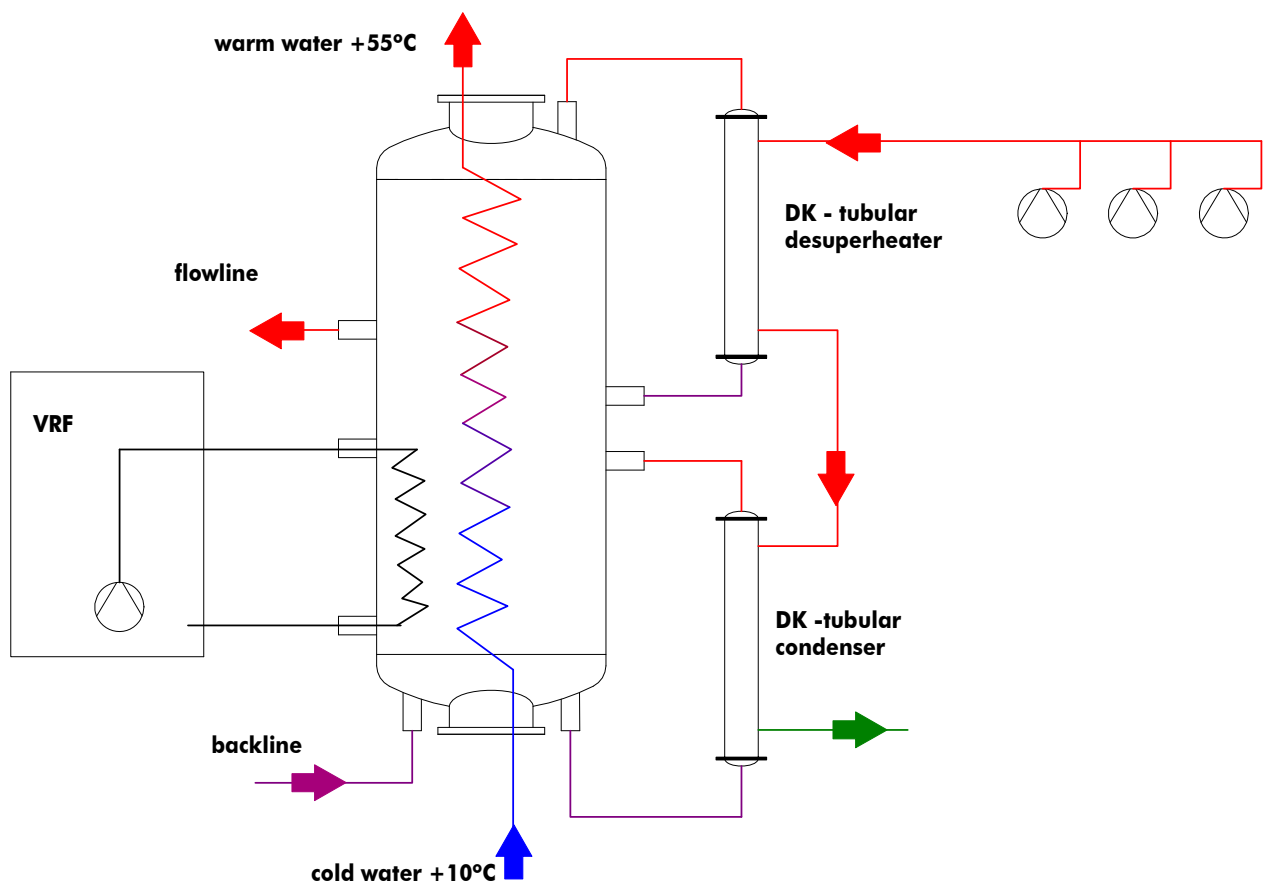

## Concepts for supermarkets Heating with commercial refrigeration

- Possibility of a heat exchanger for mains water warming
- Possibility of total heating and / or cooling with a heat pump

This drawing shows a plant that additionally provides warm water using the desuperheating of the combined plant. Heating and hot water tanks can be arranged one above the other under an insulation layer.

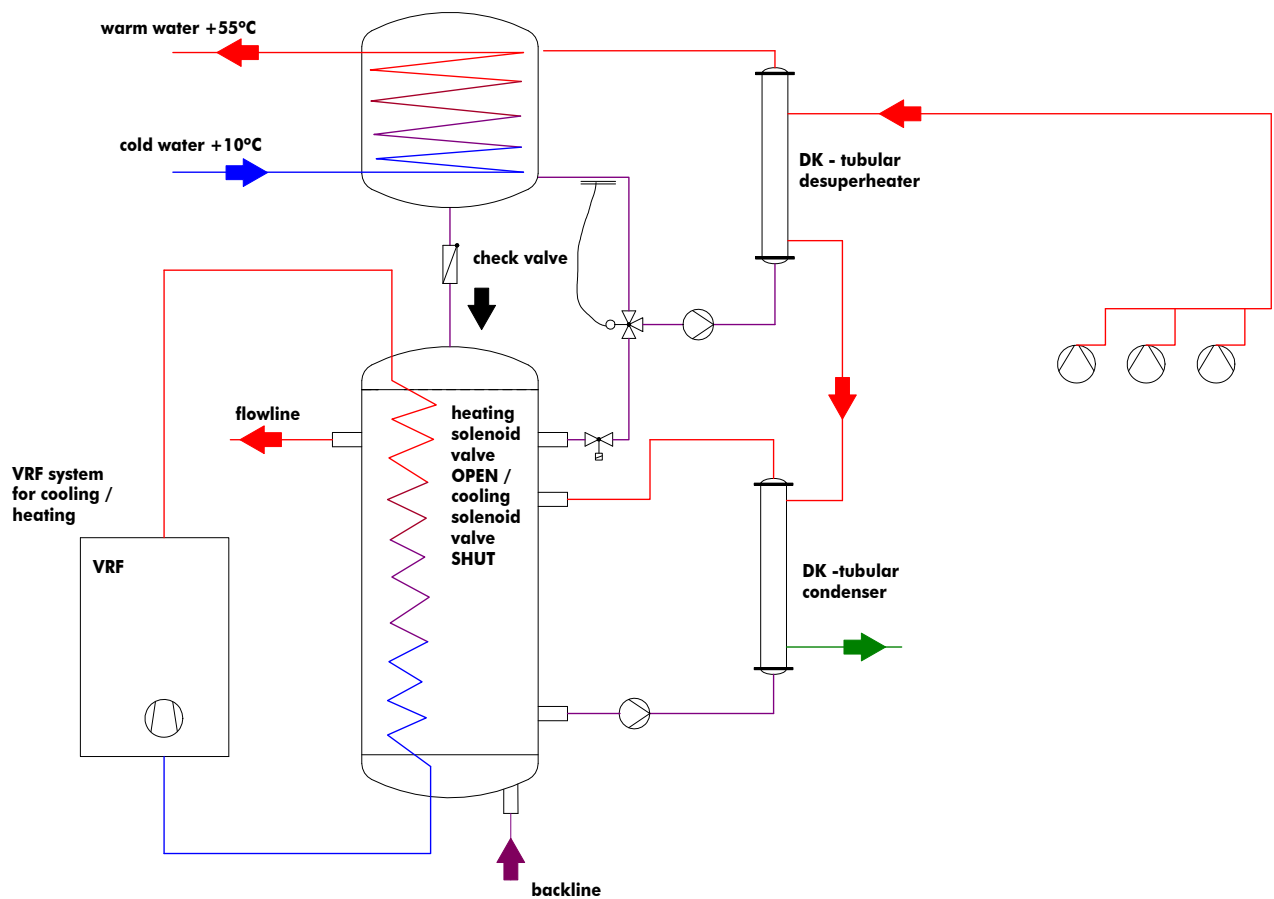

## Concepts for Residential Constructions

The DK-Heat Pump Storage Tank serves the strongly-grown demand for heat pumps used for heating and potable water.

The refrigeration unit's waste heat is used to warm up heating water via the heat exchangers (condenser). It is also possible to connect additional heat exchangers such as solar heat exchangers, as well as other heating sources.

By using a potable water bubble it is possible for a single vessel to heat potable water, which can be sensibly used to fill, for example, a bathtub.

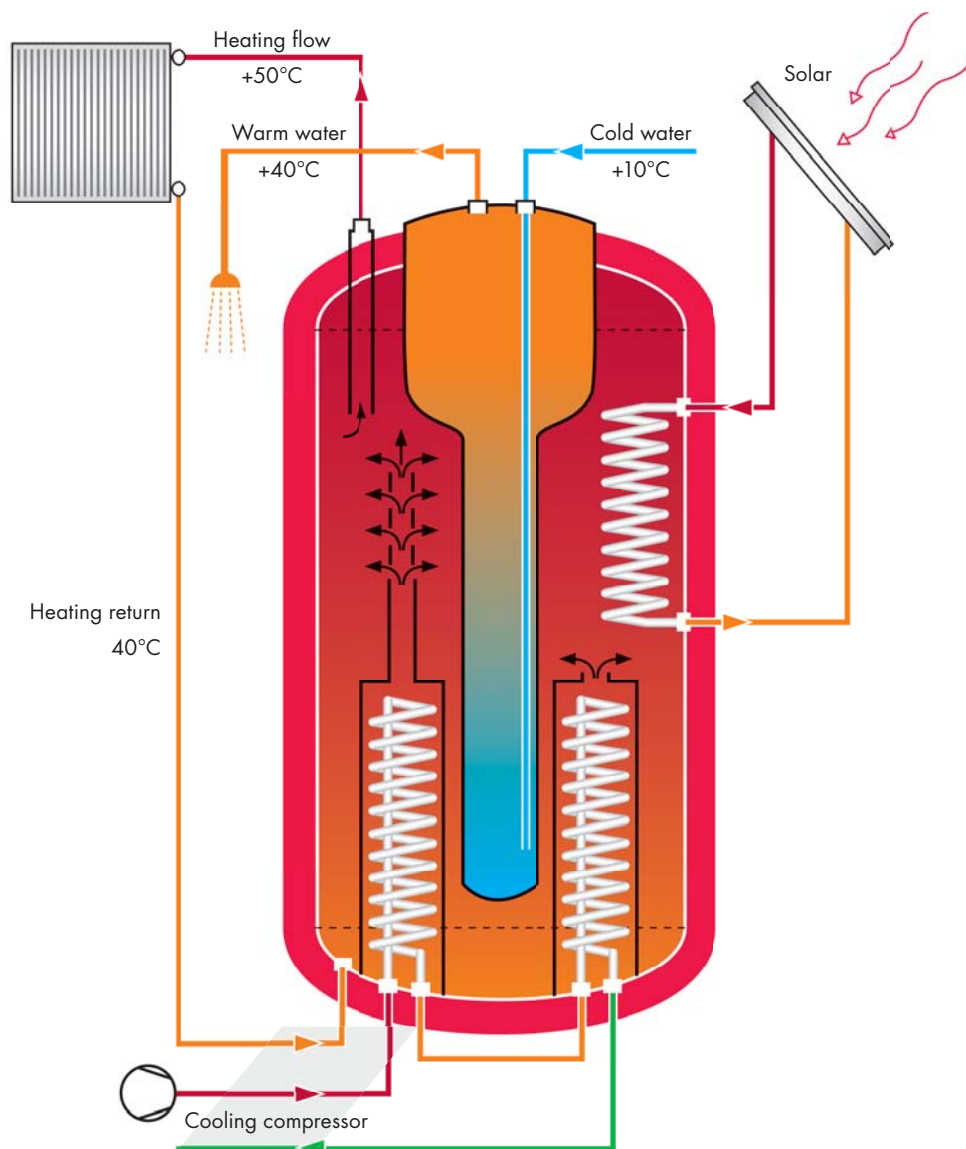



Cooling. Heating.  
Innovation.

## DK-Heat Recovery Type 120/1

front view

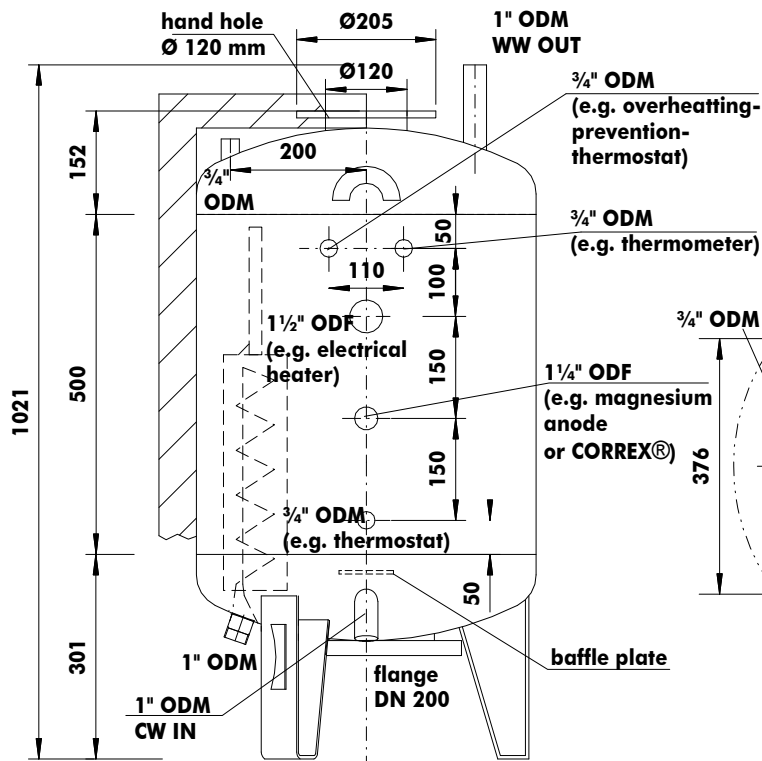

top view

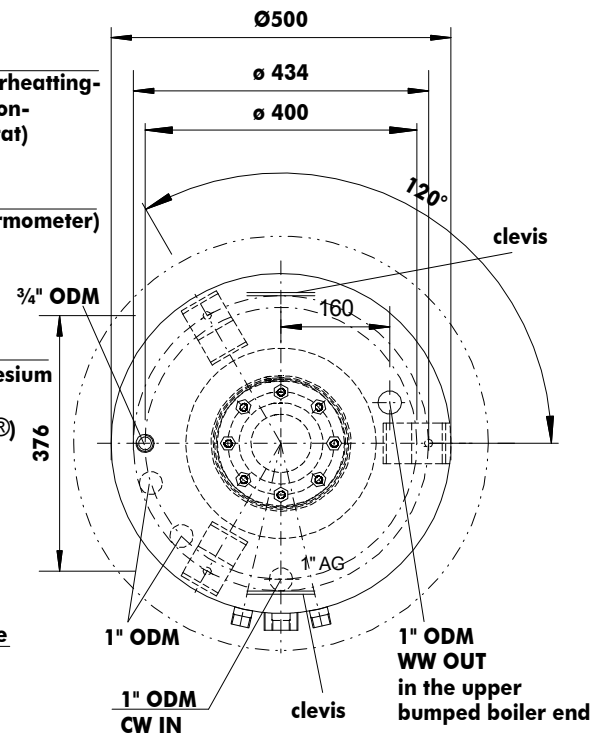

### Technical specifications

Height of storage tank	1021 mm
Ø excl. isolation	500 mm
Ø incl. PU foam isolation	-
Ø incl. soft flies isolation	620 mm / 80 mm flies with PVC covering
Content	120 l
Weight	50 kg
Corrosion protection outside	enamel mist
Corrosion protection inside	double enamel layer
Working pressure	6 bar



Cooling. Heating.  
Innovation.

## DK-Heat Recovery Type 200/1

front view

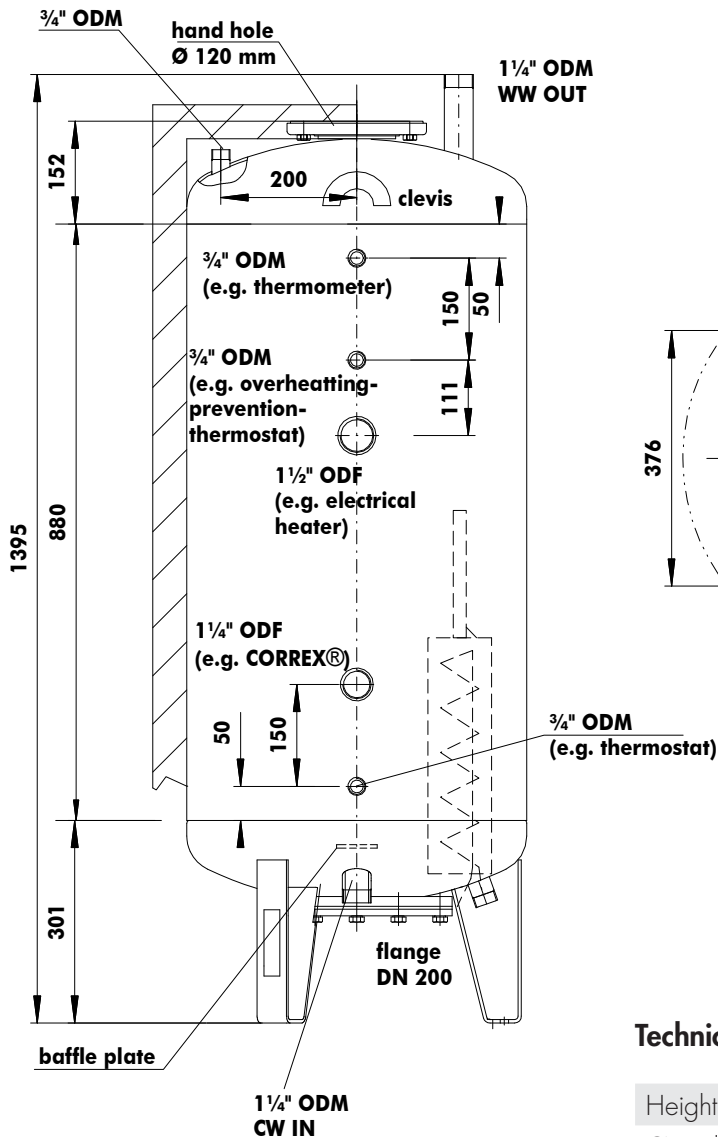

top view

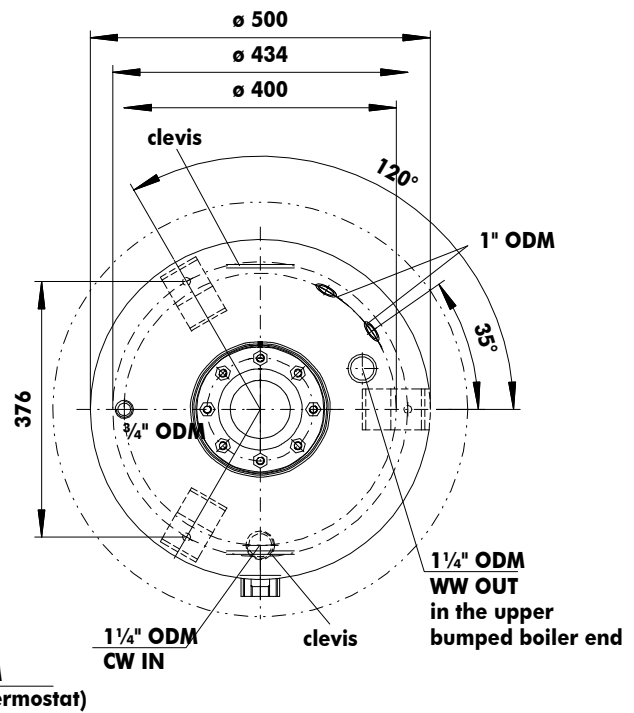

### Technical specifications

Height of storage tank	1395 mm
Ø excl. isolation	500 mm
Ø incl. PU foam isolation	610 mm / PU foam 55mm with GRP hardshell
Ø incl. soft flies isolation	620 mm / 80 mm flies with PVC covering
Content	200 l
Weight	95 kg
Corrosion protection outside	enamel mist
Corrosion protection inside	double enamel layer
Working pressure	6 bar



Cooling. Heating.  
Innovation.

## DK-Heat Recovery Type 300/1

front view

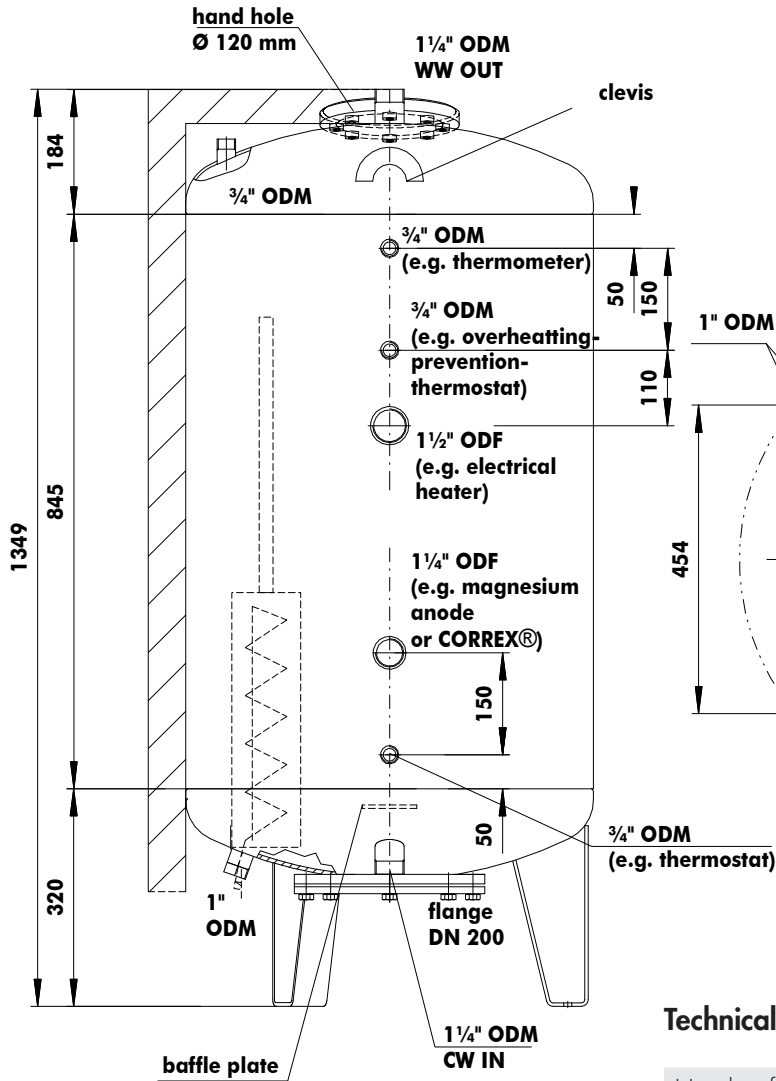

top view

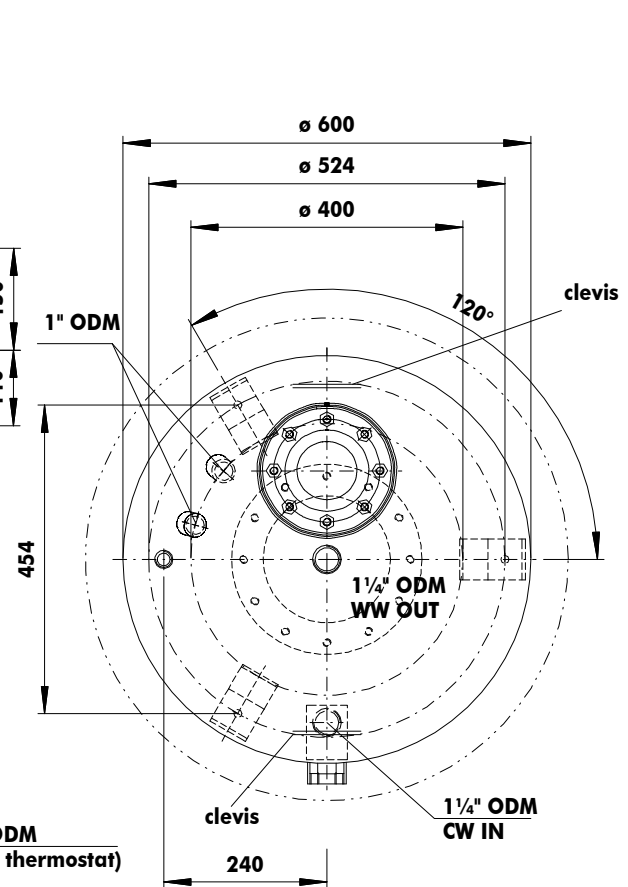

### Technical specifications

Height of storage tank	1349 mm
Ø excl. isolation	600 mm
Ø incl. PU foam isolation	710 mm / PU foam 55mm with GRP hardshell
Ø incl. soft flies isolation	720 mm / 80 mm flies with PVC covering
Content	300 l
Weight	110 kg
Corrosion protection outside	enamel mist
Corrosion protection inside	double enamel layer
Working pressure	6 bar





Cooling. Heating.  
Innovation.

## DK-Heat Recovery Type 300/4

front view

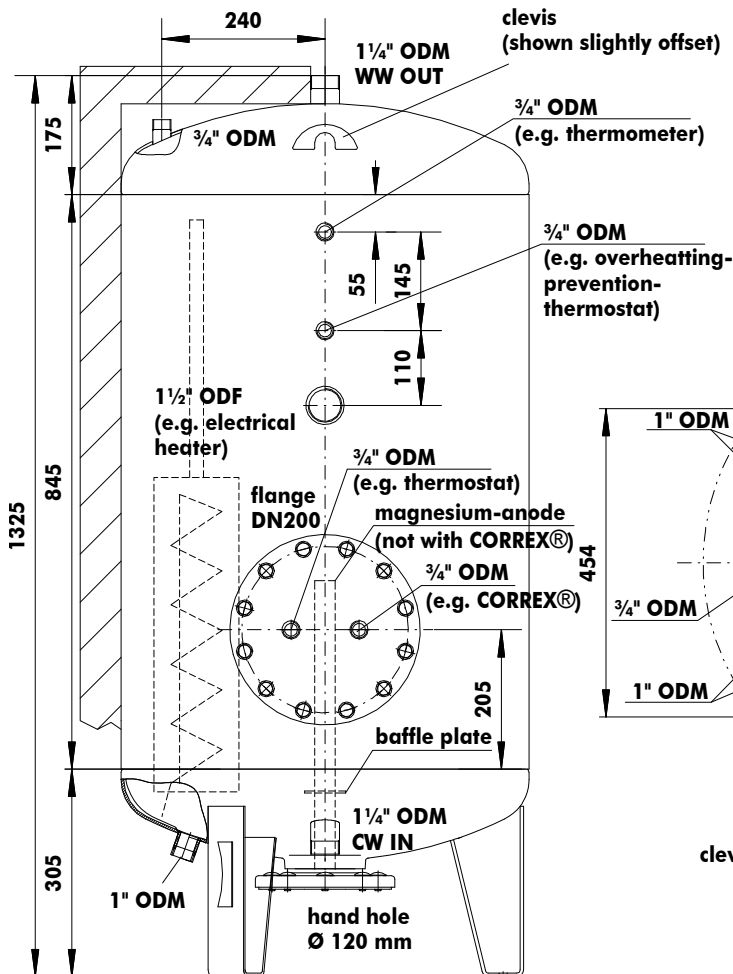

top view

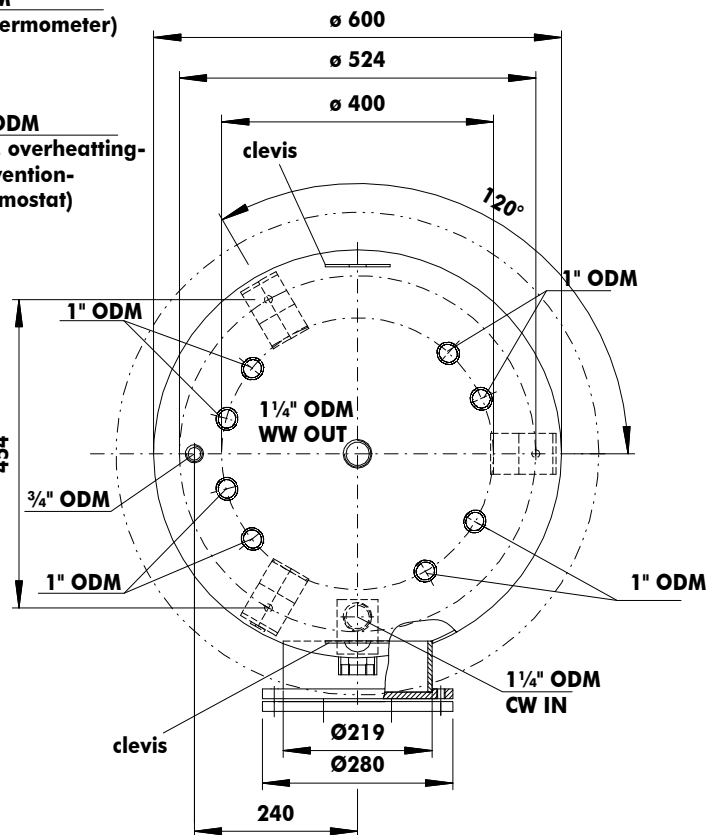

### Technical specifications

Height of storage tank	1325 mm
Ø excl. isolation	600 mm
Ø incl. PU foam isolation	710 mm / PU foam 55mm with GRP hardshell
Ø incl. soft flies isolation	720 mm / 80 mm flies with PVC covering
Content	300 l
Weight	112 kg
Corrosion protection outside	enamel mist
Corrosion protection inside	double enamel layer
Working pressure	6 bar



Cooling. Heating.  
Innovation.

## DK-Heat Recovery Type 500/1

front view

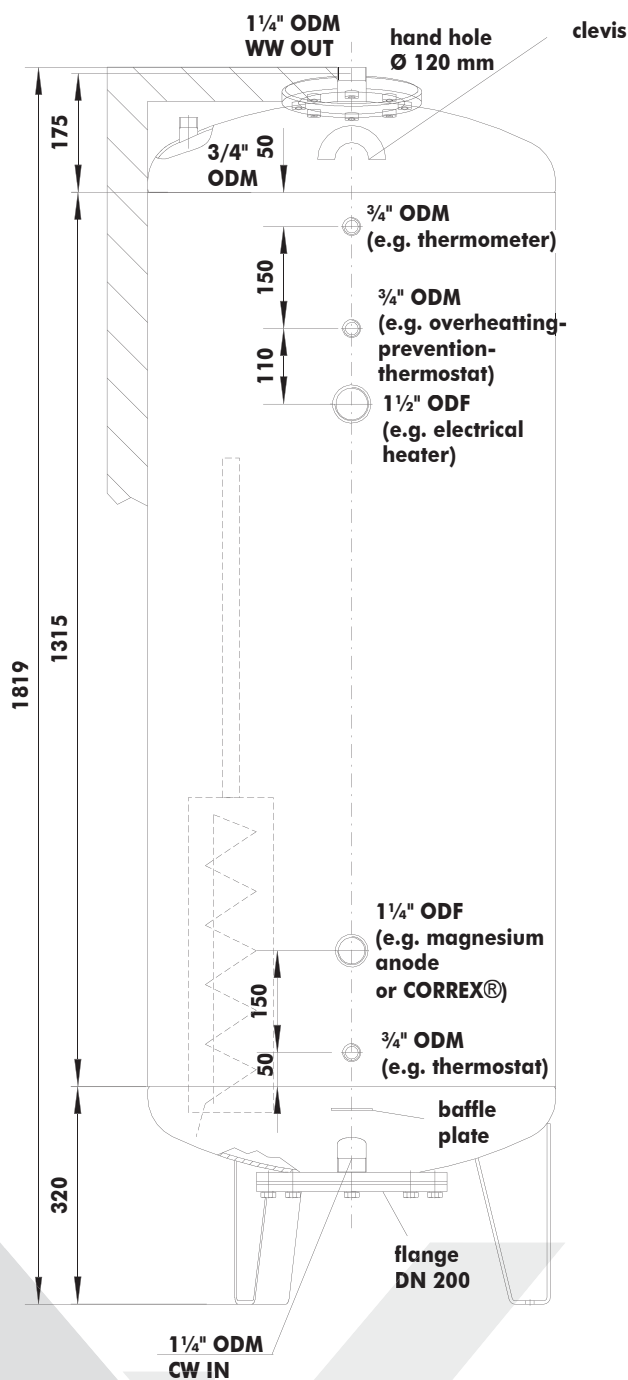

top view

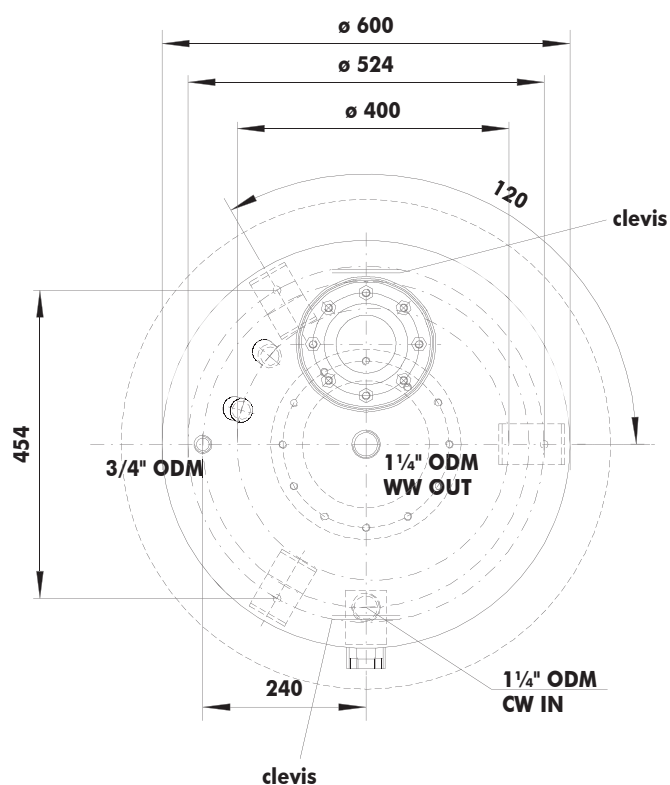

### Technical specifications

Height of storage tank	1825 mm
Ø excl. isolation	600 mm
Ø incl. PU foam isolation	710 mm / PU foam 55mm with GRP hardshell
Ø incl. soft flies isolation	720 mm / 80 mm flies with PVC covering
Content	450 l
Weight	138 kg
Corrosion protection outside	enamel mist
Corrosion protection inside	double enamel layer
Working pressure	6 bar



Cooling. Heating.  
Innovation.

## DK-Heat Recovery Type 500/4

front view

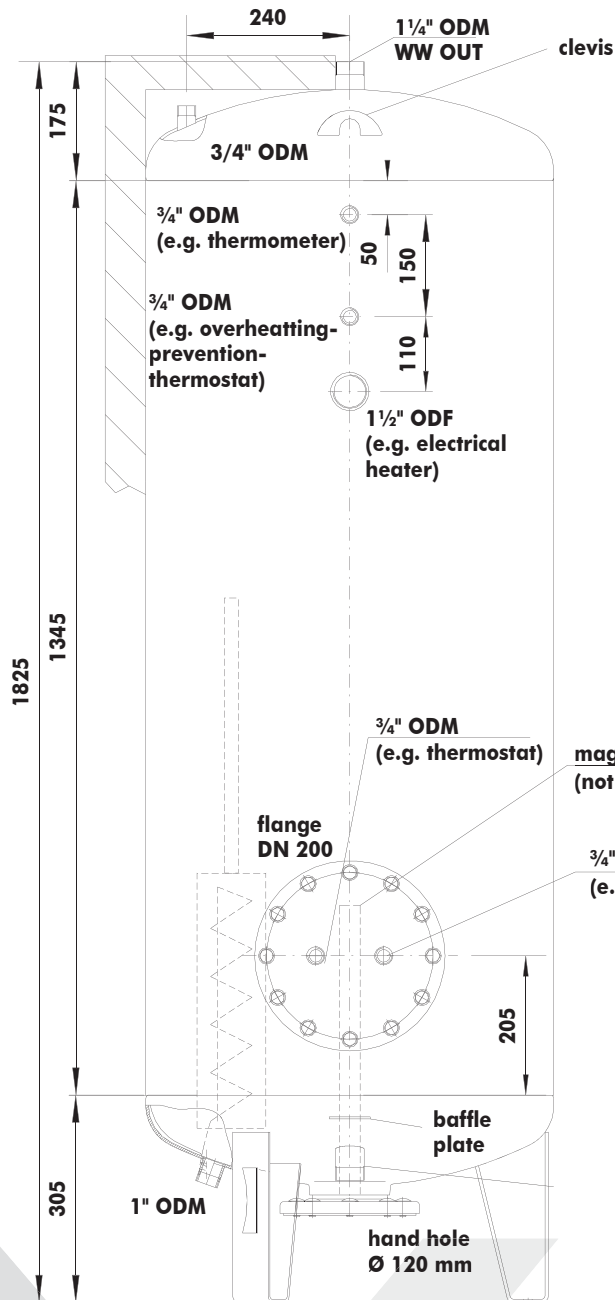

top view

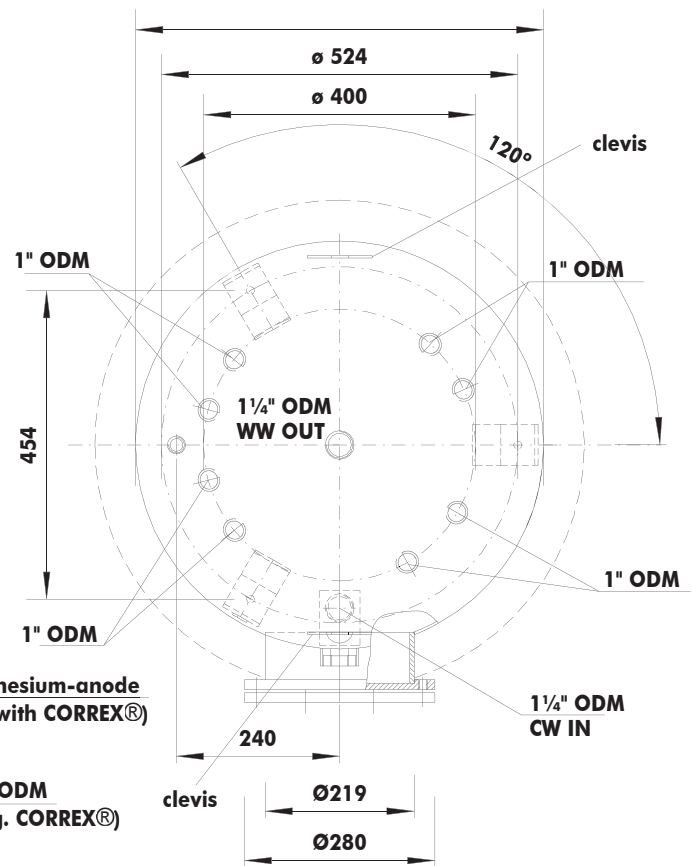

### Technical specifications

Height of storage tank	1825 mm
Ø excl. isolation	600 mm
Ø incl. PU foam isolation	710 mm / PU foam 55mm with GRP hardshell
Ø incl. soft flies isolation	720 mm / 80 mm flies with PVC covering
Content	450 l
Weight	143 kg
Corrosion protection outside	enamel mist
Corrosion protection inside	double enamel layer
Working pressure	6 bar



Cooling. Heating.  
Innovation.

## DK-Heat Recovery Type 750/5

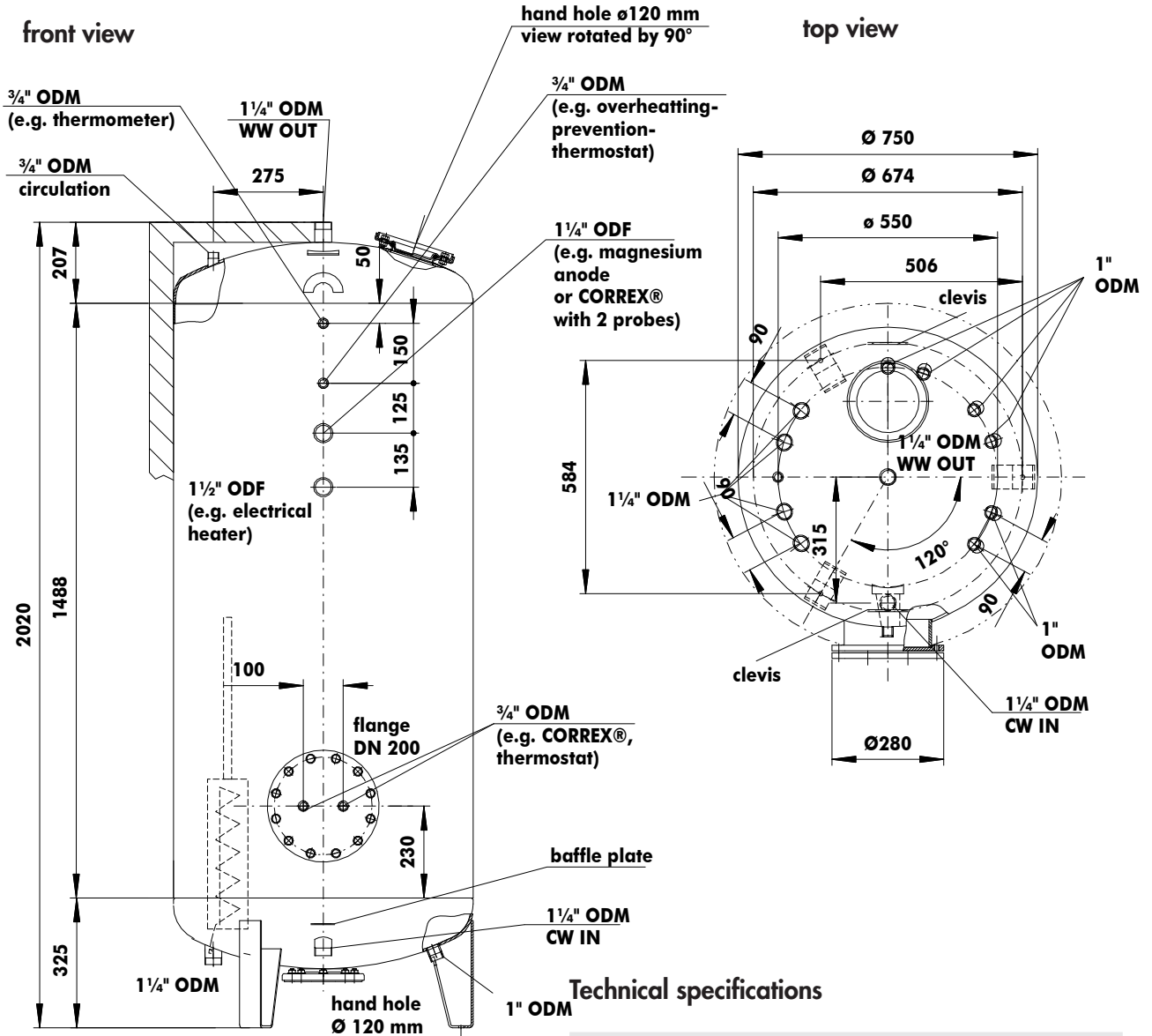

### Technical specifications

Height of storage tank	2011 mm
Ø excl. isolation	750 mm
Ø incl. PU foam isolation	860 mm / PU foam 55 mm with GRP hardshell
Ø incl. soft flies isolation	870 mm / 80 mm flies with PVC covering
Content	750 l
Weight	222 kg
Corrosion protection outside	enamel mist
Corrosion protection inside	double enamel layer
Working pressure	6 bar



Cooling. Heating.  
Innovation.

# DK-Heat Recovery Type 1000/5 - Ø 750

front view

top view

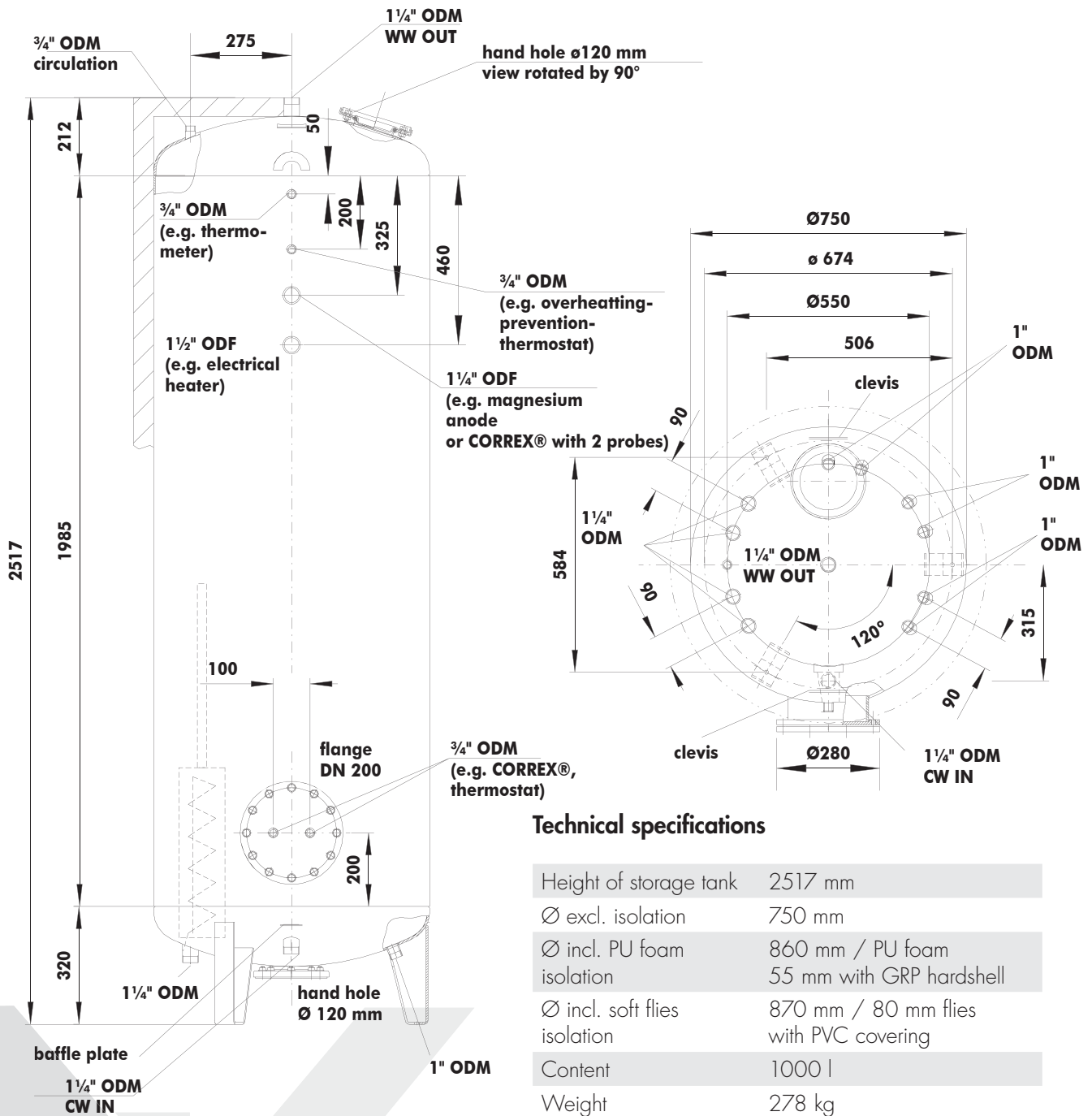

## Technical specifications

Height of storage tank	2517 mm
Ø excl. isolation	750 mm
Ø incl. PU foam isolation	860 mm / PU foam 55 mm with GRP hardshell
Ø incl. soft flies isolation	870 mm / 80 mm flies with PVC covering
Content	1000 l
Weight	278 kg
Corrosion protection outside	enamel mist
Corrosion protection inside	double enamel layer
Working pressure	6 bar



Cooling. Heating.  
Innovation.

# DK-Heat Recovery Type 1000/5 - Ø 800

front view

top view

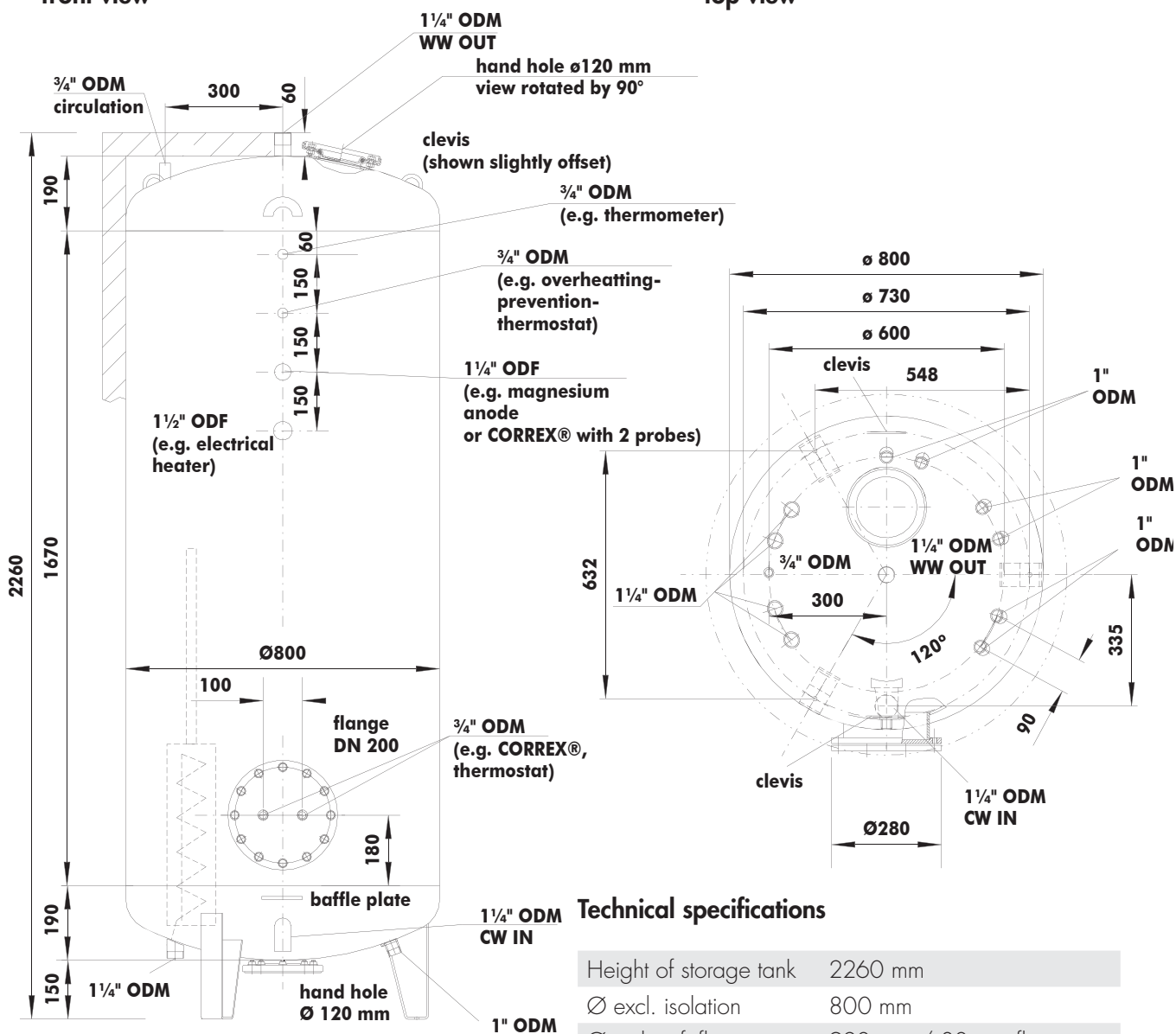

## Technical specifications

Height of storage tank	2260 mm
Ø excl. isolation	800 mm
Ø incl. soft flies isolation	920 mm / 80 mm flies with PVC covering
Content	1000 l
Weight	300 kg
Corrosion protection outside	enamel mist
Corrosion protection inside	double enamel layer
Working pressure	6 bar





Cooling. Heating.  
Innovation.

# DK-Heat Recovery Type 1000/5 - Ø 900

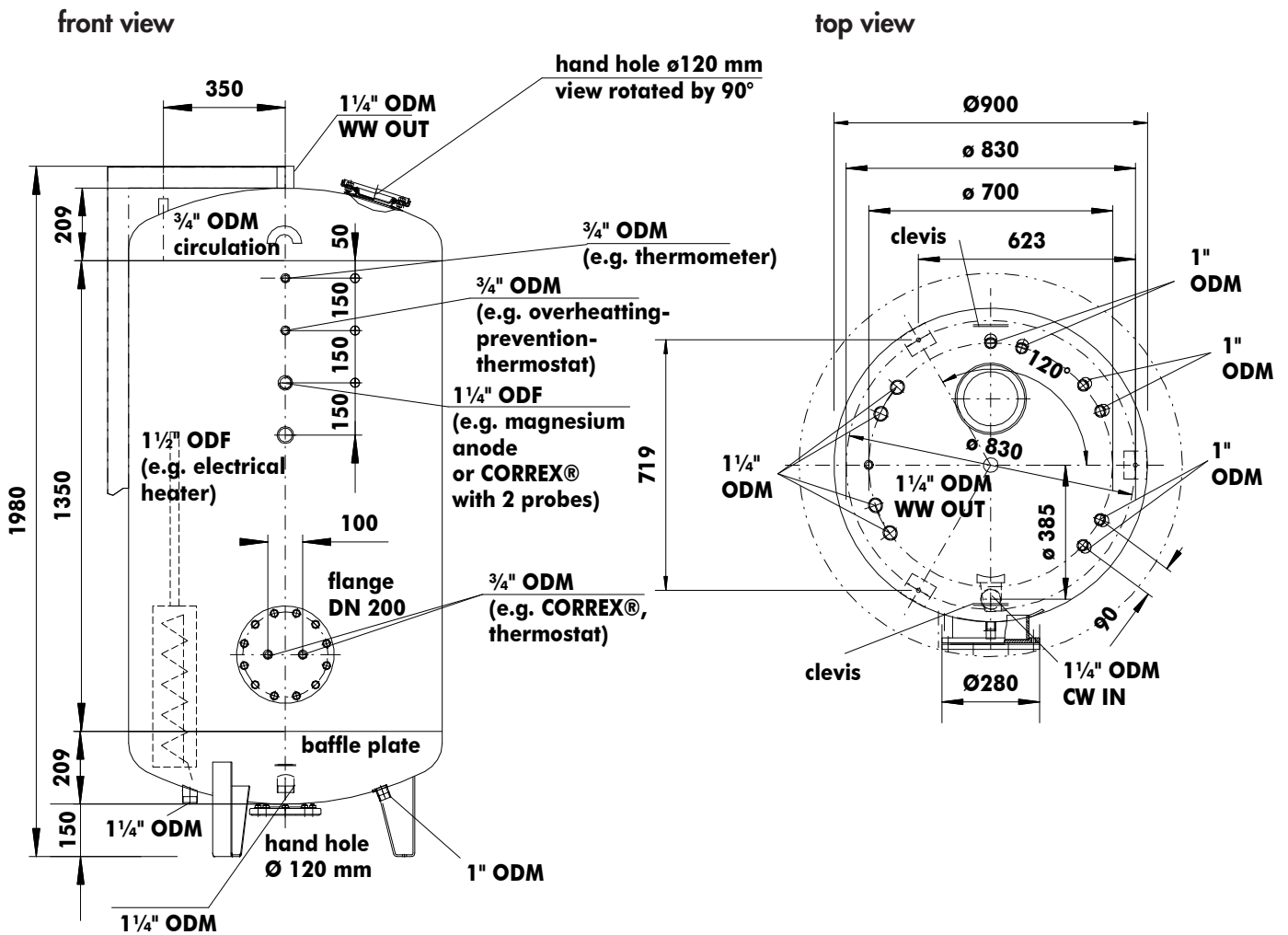

## Technical specifications

Height of storage tank	1980 mm
Ø excl. isolation	900 mm
Ø incl. PU foam isolation	1020 mm / 80 mm flies with PVC covering
Content	1000 l
Weight	340 kg
Corrosion protection outside	enamel mist
Corrosion protection inside	double enamel layer
Working pressure	6 bar



Cooling. Heating.  
Innovation.

# DK-Heat Recovery Type 1500 bis 7000

front view

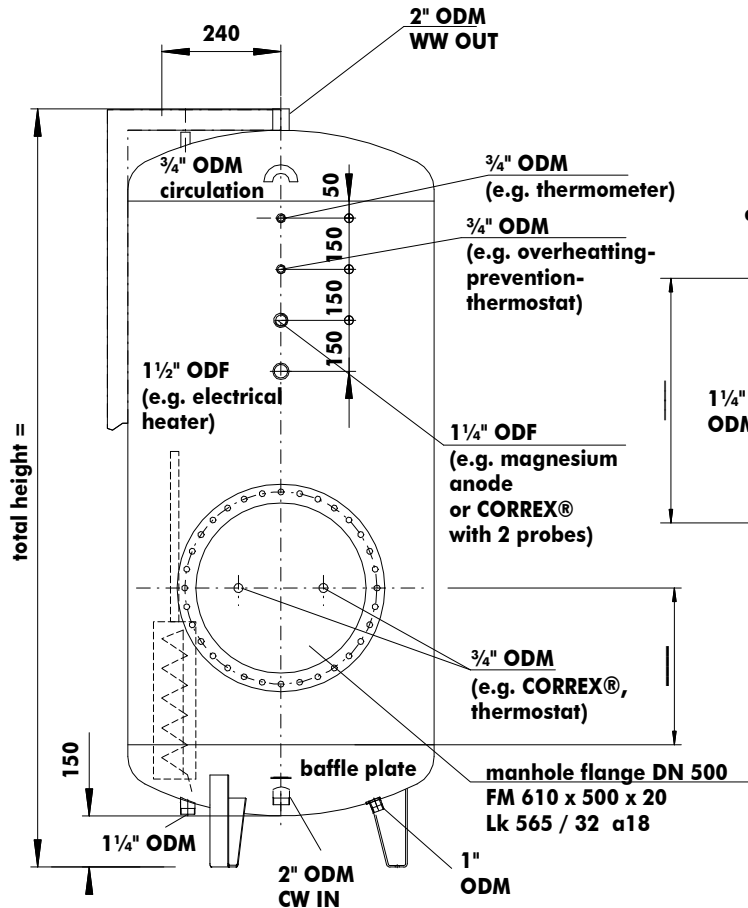

top view

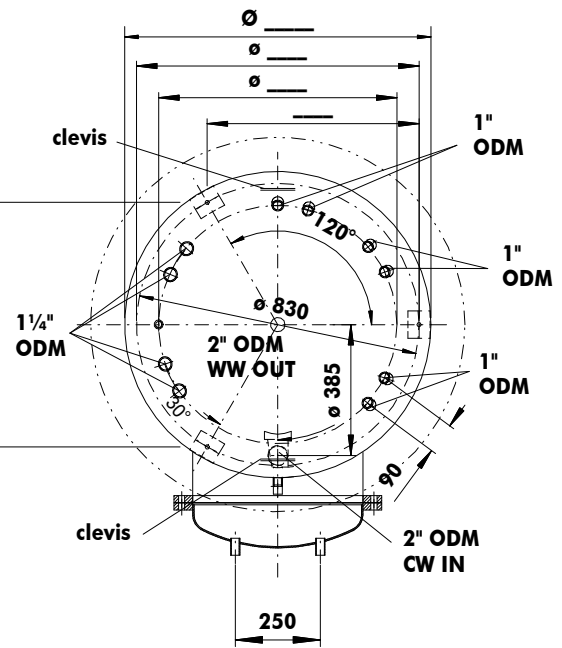

Content (l)	Diameter (mm)	Overall height (mm)	max. no. of installed Heat Exchanger
1,500	1,000	2,200	12 pcs
1,500	900	2,500	10 pcs
2,000	1,100	2,400	12 pcs
2,000	1,200	2,000	12 pcs
3,000	1,400	2,350	14 pcs
3,000	1,300	3,550	14 pcs
3,000	1,200	2,800	12 pcs
5,000	1,500	3,200	16 pcs
5,000	1,600	2,850	20 pcs
5,000	1,800	2,300	24 pcs
7,000	2,000	2,600	30 pcs





Cooling. Heating.  
Innovation.

## DK-Buffer Tank Type 300

front view

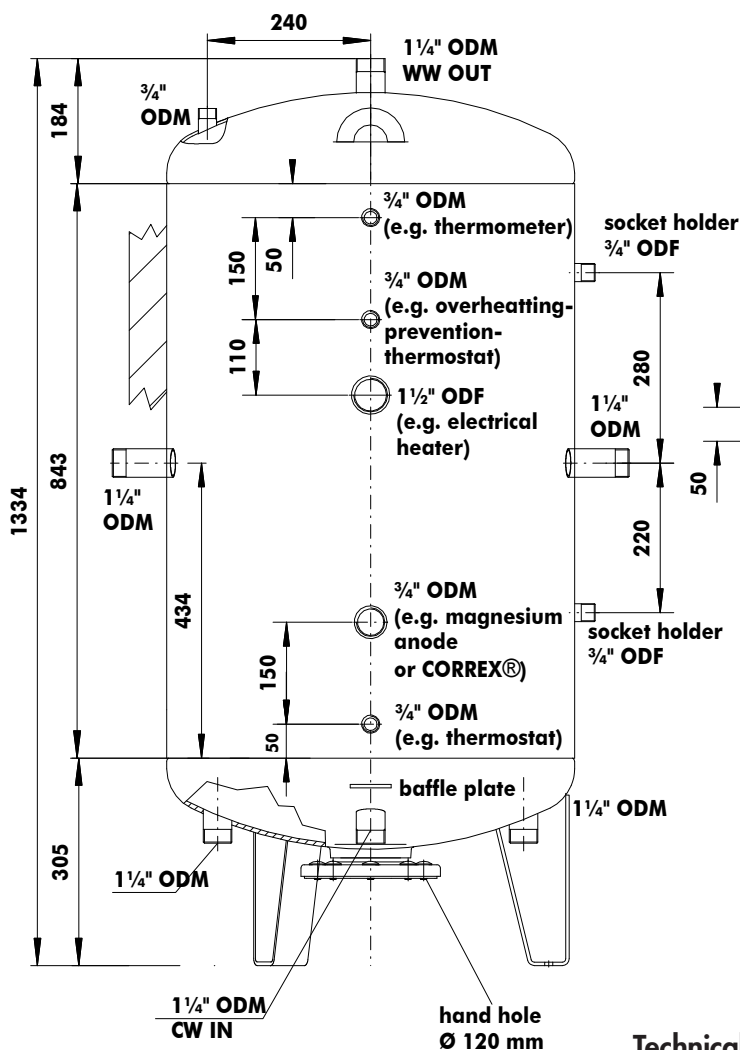

top view

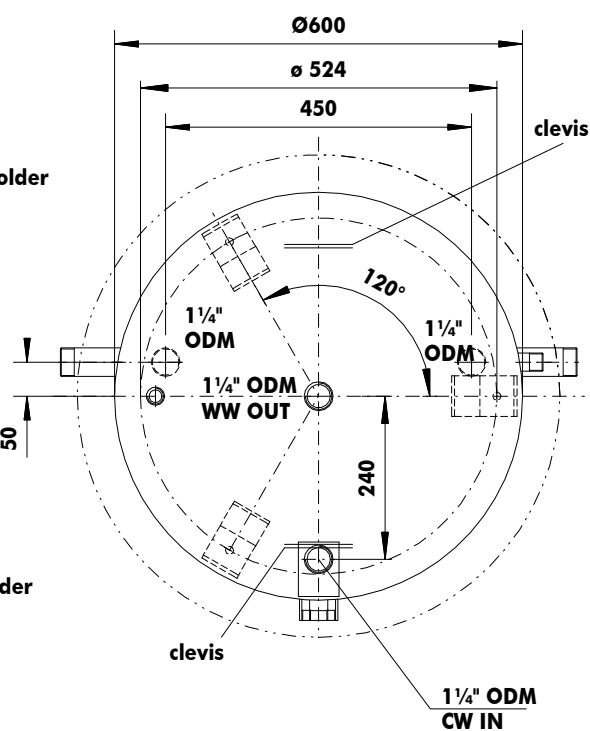

### Technical specifications

Height of storage tank	1334 mm
Ø excl. isolation	600 mm
Ø incl. PU foam isolation	710 mm / PU foam 55mm with GRP hardshell
Ø incl. soft flies isolation	720 mm / 80 mm flies with PVC covering
Content	300 l
Weight	102 kg
Corrosion protection outside	enamel mist
Corrosion protection inside	double enamel layer
Working pressure	6 bar



Cooling. Heating.  
Innovation.

# DK-Buffer Tank Type 450

front view

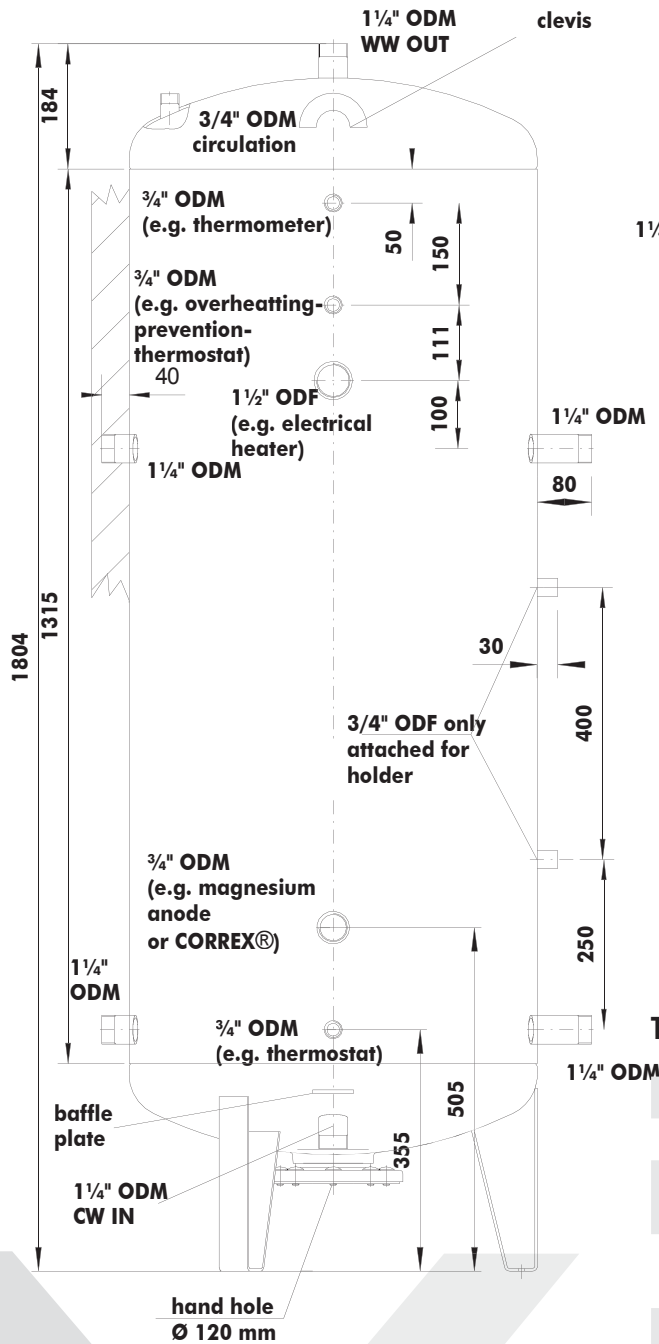

top view

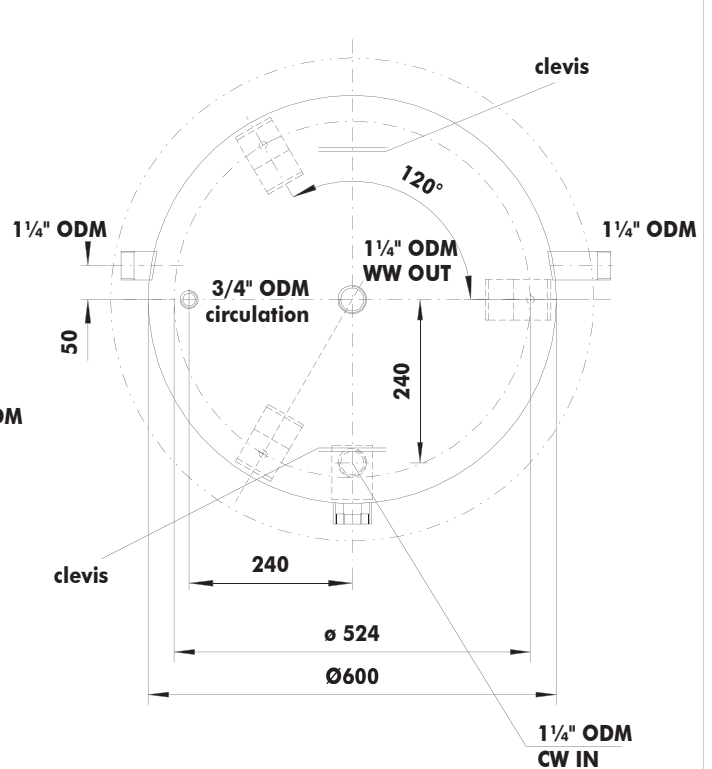

## Technical specifications

Height of storage tank	1804 mm
Ø excl. isolation	600 mm
Ø incl. PU foam isolation	710 mm / PU foam 55mm with GRP hardshell
Ø incl. soft flies isolation	720 mm / 80 mm flies with PVC covering
Content	450 l
Weight	133 kg
Corrosion protection outside	enamel mist
Corrosion protection inside	double enamel layer
Working pressure	6 bar



Cooling. Heating.  
Innovation.

# DK-Buffer Tank Type 750

front view

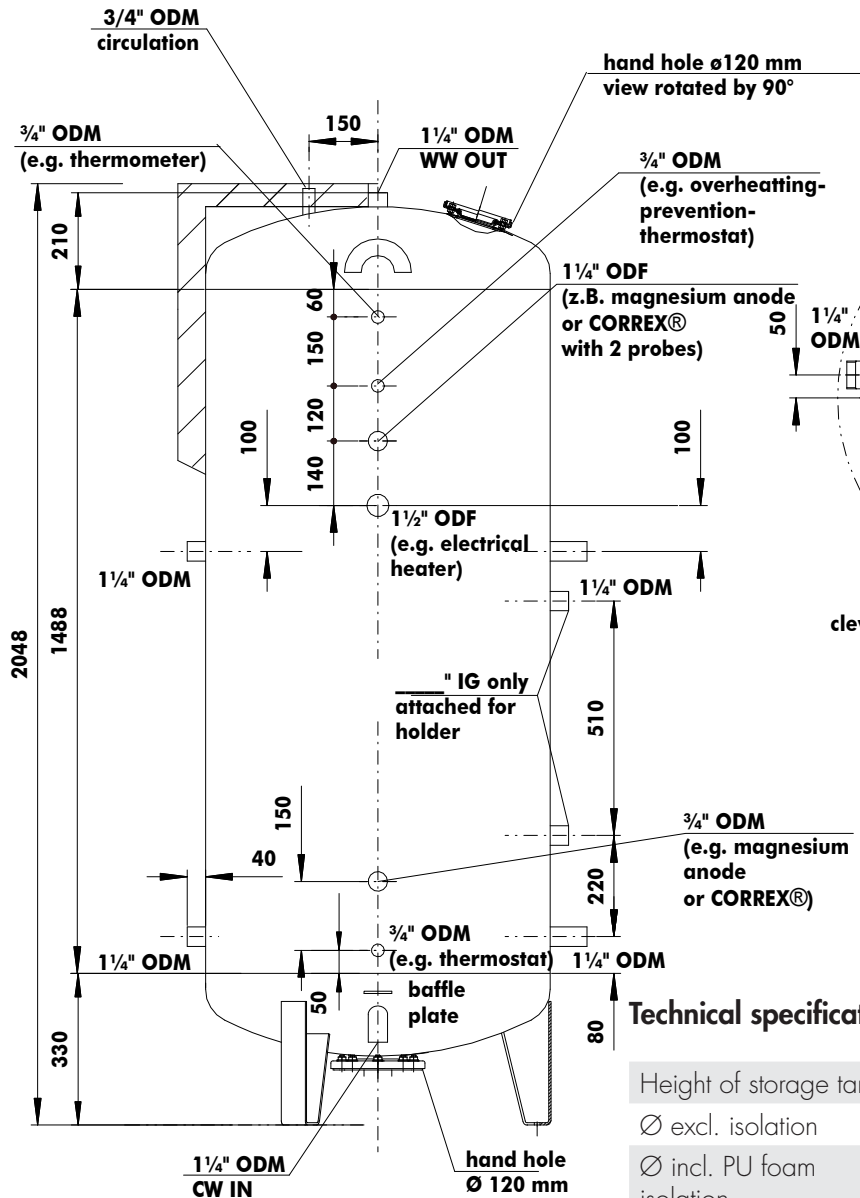

top view

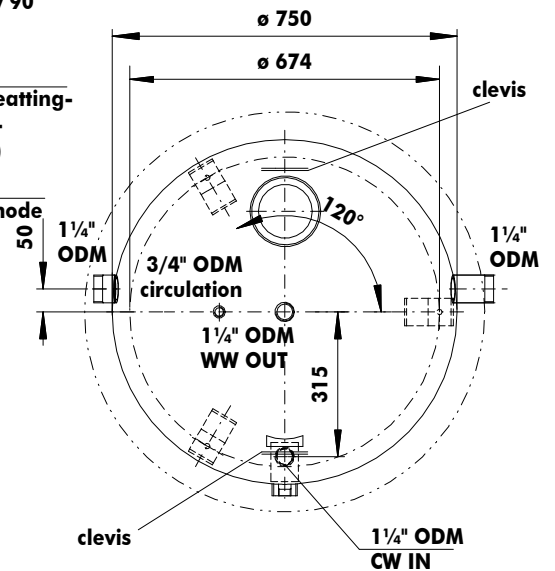

## Technical specifications

Height of storage tank	2048 mm
Ø excl. isolation	750 mm
Ø incl. PU foam isolation	860 mm / PU foam 55mm with GRP hardshell
Ø incl. soft flies isolation	870 mm / 80 mm flies with PVC covering
Content	750 l
Weight	213 kg
Corrosion protection outside	enamel mist
Corrosion protection inside	double enamel layer
Working pressure	6 bar



Cooling. Heating.  
Innovation.

# DK-Buffer Tank Type 1000

front view

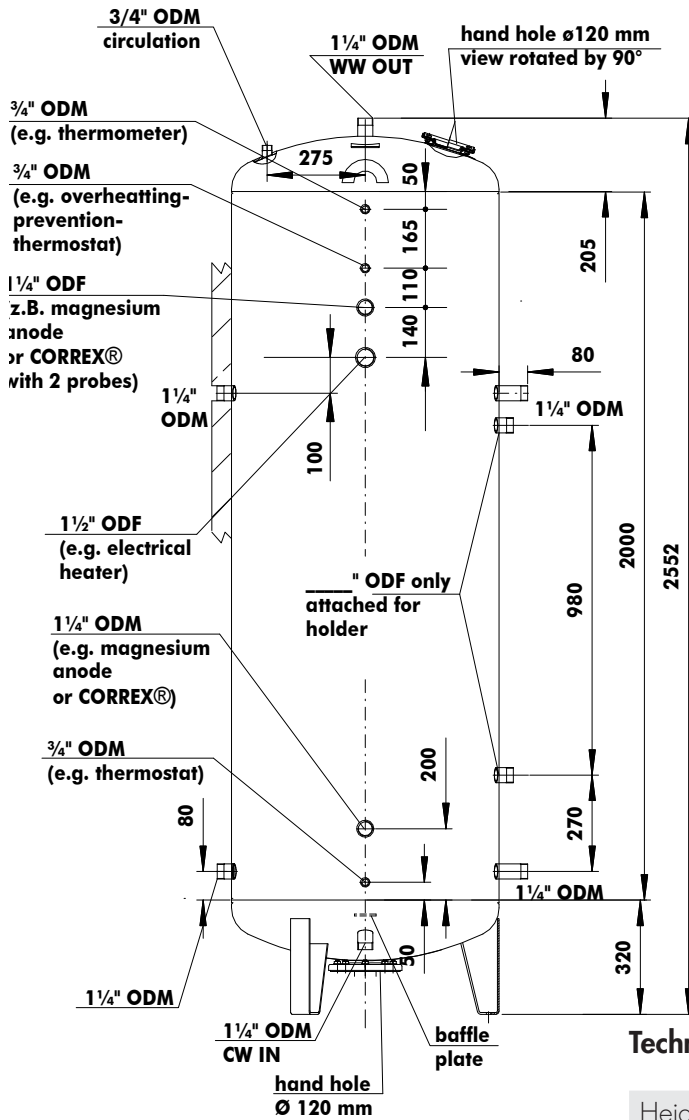

top view

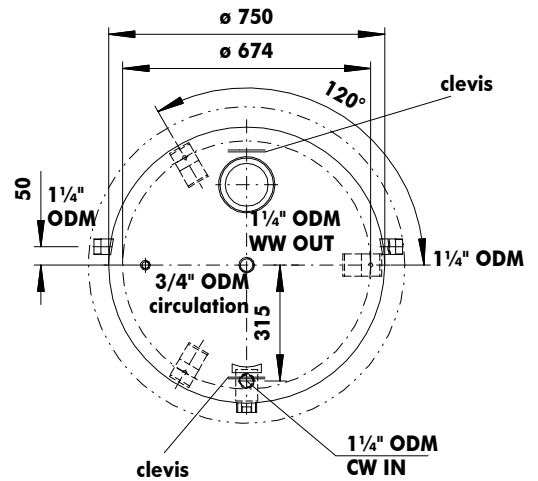

## Technical specifications

Height of storage tank	2552 mm
Ø excl. isolation	750 mm
Ø incl. PU foam isolation	860 mm / PU foam 55mm with GRP hardshell
Ø incl. soft flies isolation	870 mm / 80 mm flies with PVC covering
Content	1000 l
Weight	267 kg
Corrosion protection outside	enamel mist
Corrosion protection inside	double enamel layer
Working pressure	6 bar



Cooling. Heating.  
Innovation.

# DK-Buffer Tank Type 1500 bis 7000

front view

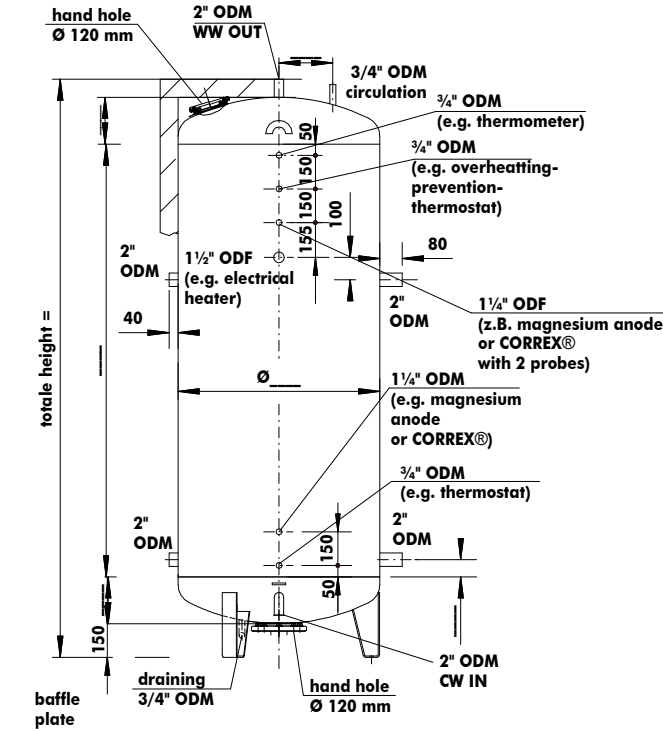

up to ø 1200mm  
shell sections / max. 2000mm

top view

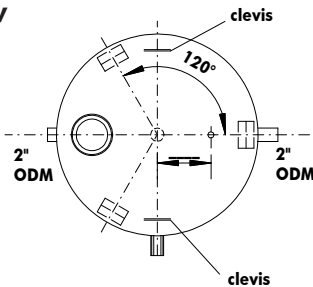

top view

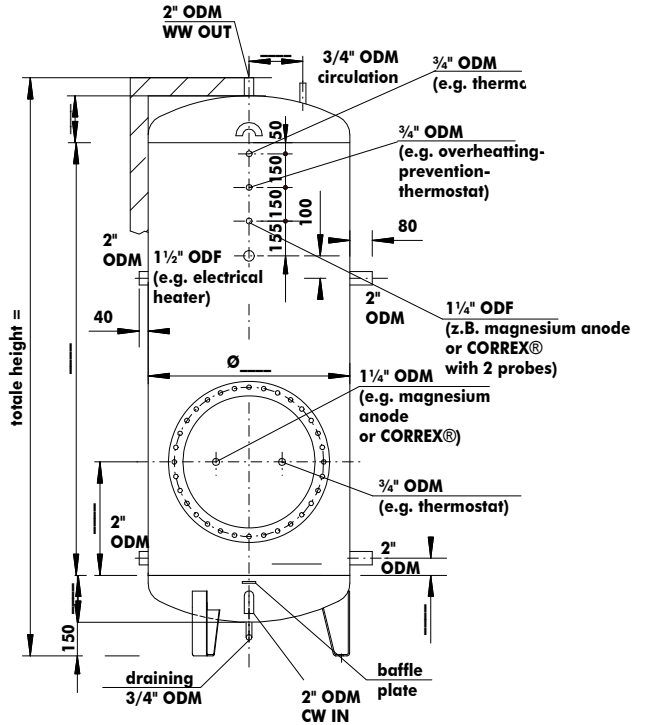

up to ø 1300mm  
shell sections / from 2000mm

top view

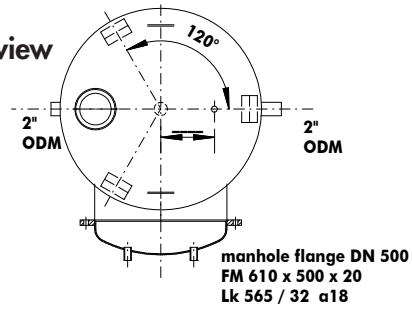

Content (l)	Diameter (mm)	Overall height (mm)
1,500	1,000	2,200
1,500	900	2,500
2,000	1,100	2,400
2,000	1,200	2,000
3,000	1,400	2,350
3,000	1,300	3,550
3,000	1,200	2,800
5,000	1,500	3,200
5,000	1,600	2,850
5,000	1,800	2,300
7,000	2,000	2,600



Cooling. Heating.  
Innovation.

## Standard mounting bracket for external tubular heat exchanger

If there are 3 foods one mounting bracket will be in the middle of the heat exchanger

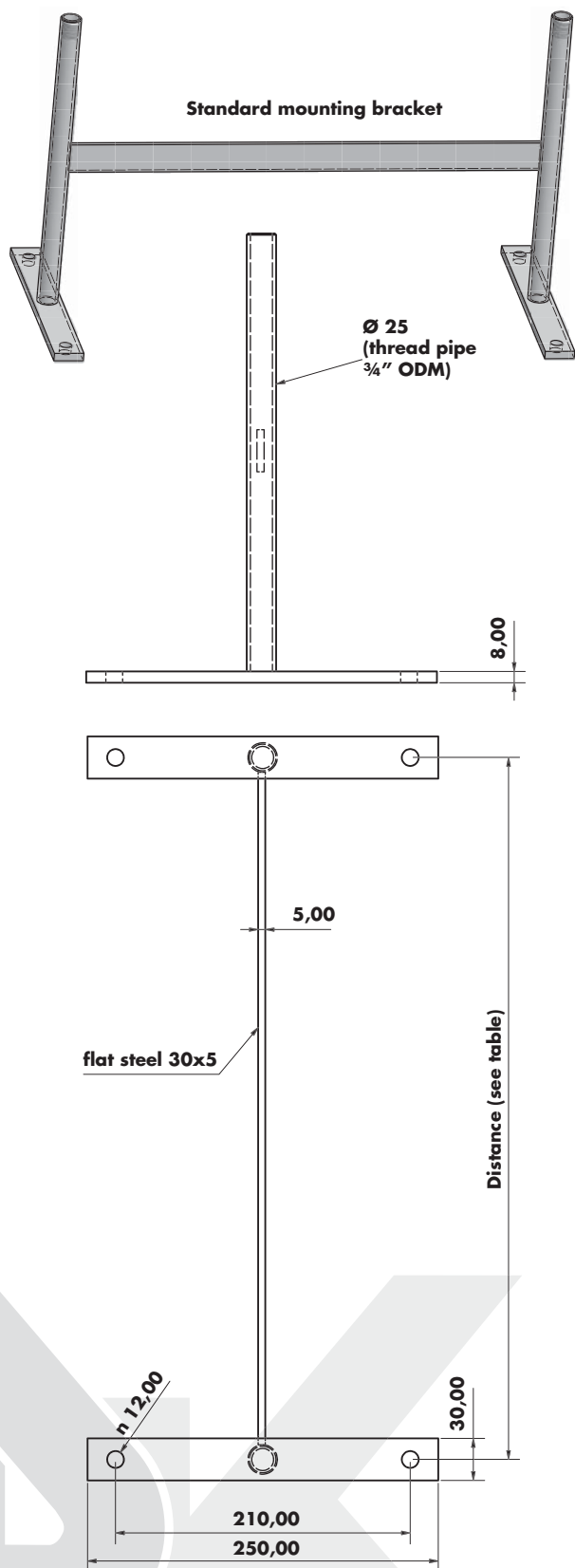

Length of the finned tube	Distance between mountings	Number of feet
400 mm	200 mm	2 Feet
500 mm	200 mm	2 Feet
600 mm	200 mm	2 Feet
700 mm	200 mm	2 Feet
800 mm	400 mm	2 Feet
900 mm	400 mm	2 Feet
1000 mm	500 mm	2 Feet
1100 mm	500 mm	2 Feet
1200 mm	700 mm	2 Feet
1300 mm	700 mm	2 Feet
1400 mm	900 mm	2 Feet
1500 mm	900 mm	2 Feet
1600 mm	1100 mm	2 Feet
1700 mm	1100 mm	2 Feet
1800 mm	1300 mm	2 Feet
1900 mm	1300 mm	2 Feet
2000 mm	1500 mm	2 Feet
2100 mm	1500 mm	2 Feet
2200 mm	1700 mm	2 Feet
2300 mm	1700 mm	2 Feet
2400 mm	1900 mm	2 Feet
2500 mm	1900 mm	2 Feet
2600 mm	2100 mm	2 Feet
2700 mm	2100 mm	2 Feet
2800 mm	2400 mm	2 Feet
2900 mm	2400 mm	2 Feet
3000 mm	2400 mm	2 Feet
3100 mm	2600 mm	3 Feet
3200 mm	2700 mm	3 Feet
3300 mm	2800 mm	3 Feet
3400 mm	2900 mm	3 Feet
3500 mm	3000 mm	3 Feet
3600 mm	3100 mm	3 Feet
3700 mm	3200 mm	3 Feet
3800 mm	3300 mm	3 Feet
3900 mm	3400 mm	3 Feet
4000 mm	3500 mm	3 Feet
4100 mm	3600 mm	3 Feet
4200 mm	3700 mm	3 Feet
4300 mm	3800 mm	3 Feet
4400 mm	3900 mm	3 Feet
4500 mm	4000 mm	3 Feet
4600 mm	4100 mm	3 Feet
4700 mm	4200 mm	3 Feet
4800 mm	4300 mm	3 Feet
4900 mm	4400 mm	3 Feet
5000 mm	4500 mm	3 Feet



Cooling. Heating.  
Innovation.

## DK-Heat Recovery – service water with after heat

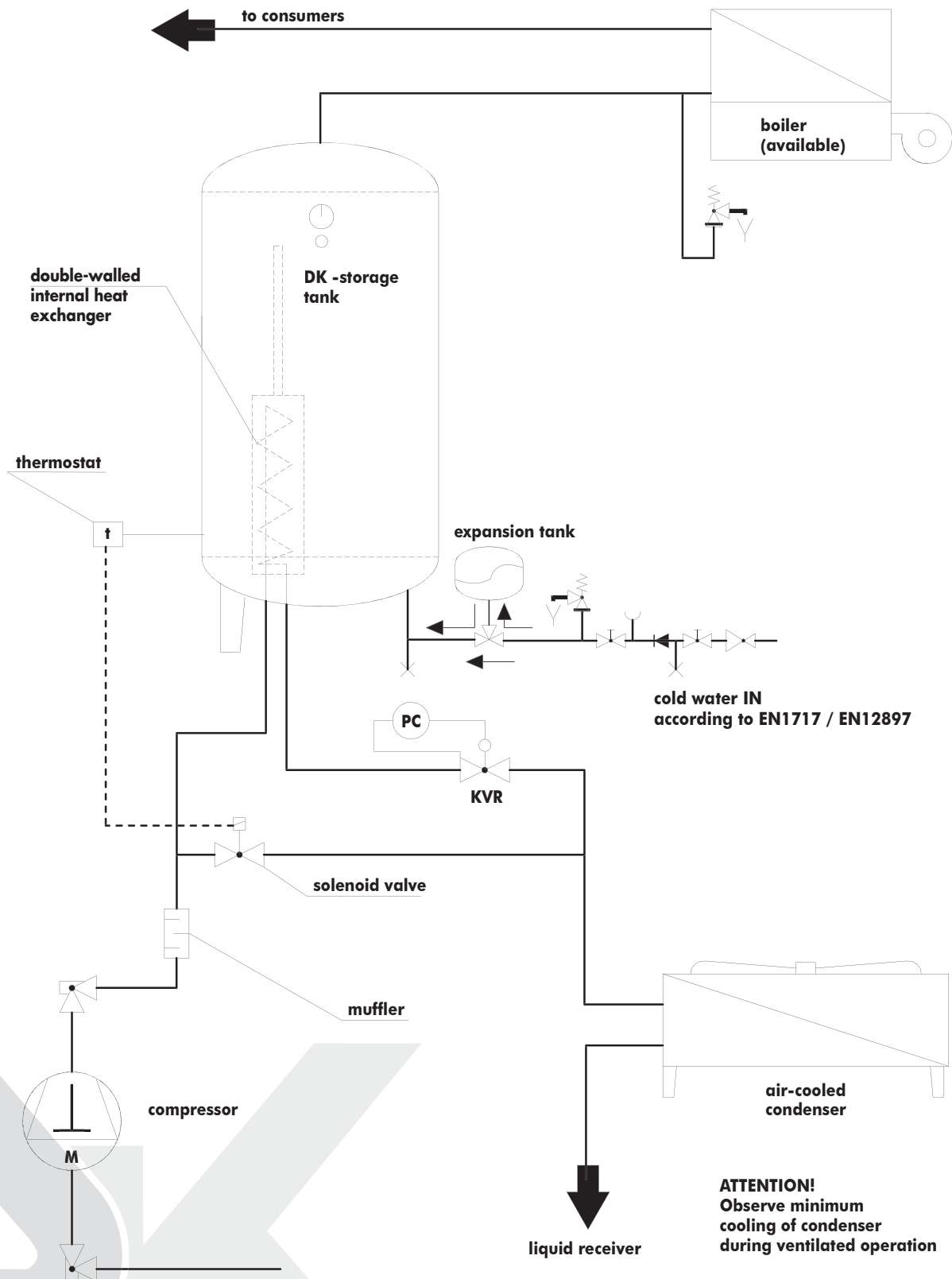



Cooling. Heating.  
Innovation.

## DK-Heat Recovery – service water with after heat through heating water

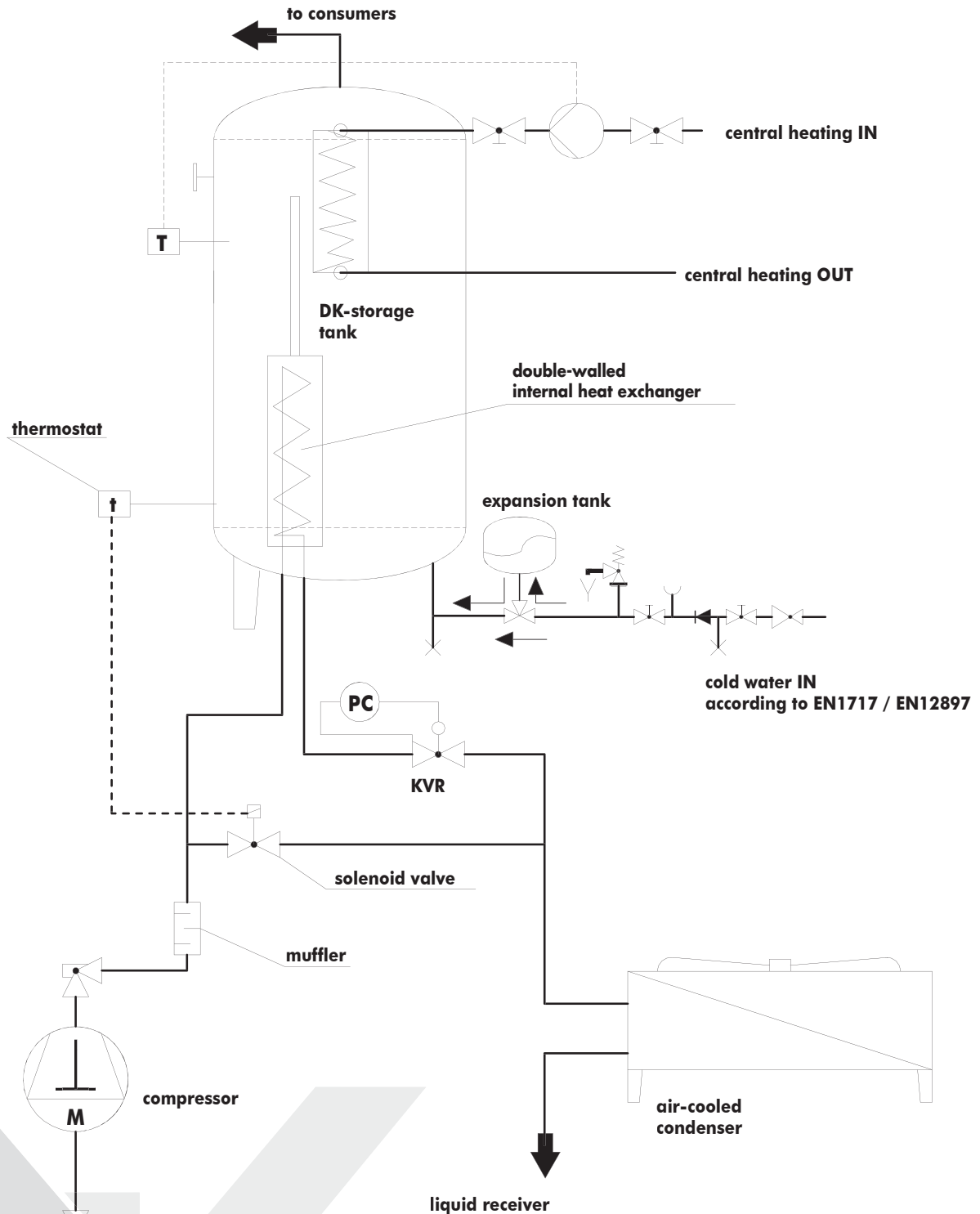

**ATTENTION!**  
Observe minimum cooling  
of condenser during  
ventilated operation





Cooling. Heating.  
Innovation.

# Combined DK-Heat Recovery System with a mains water storage tank and a storage tank for heating purposes

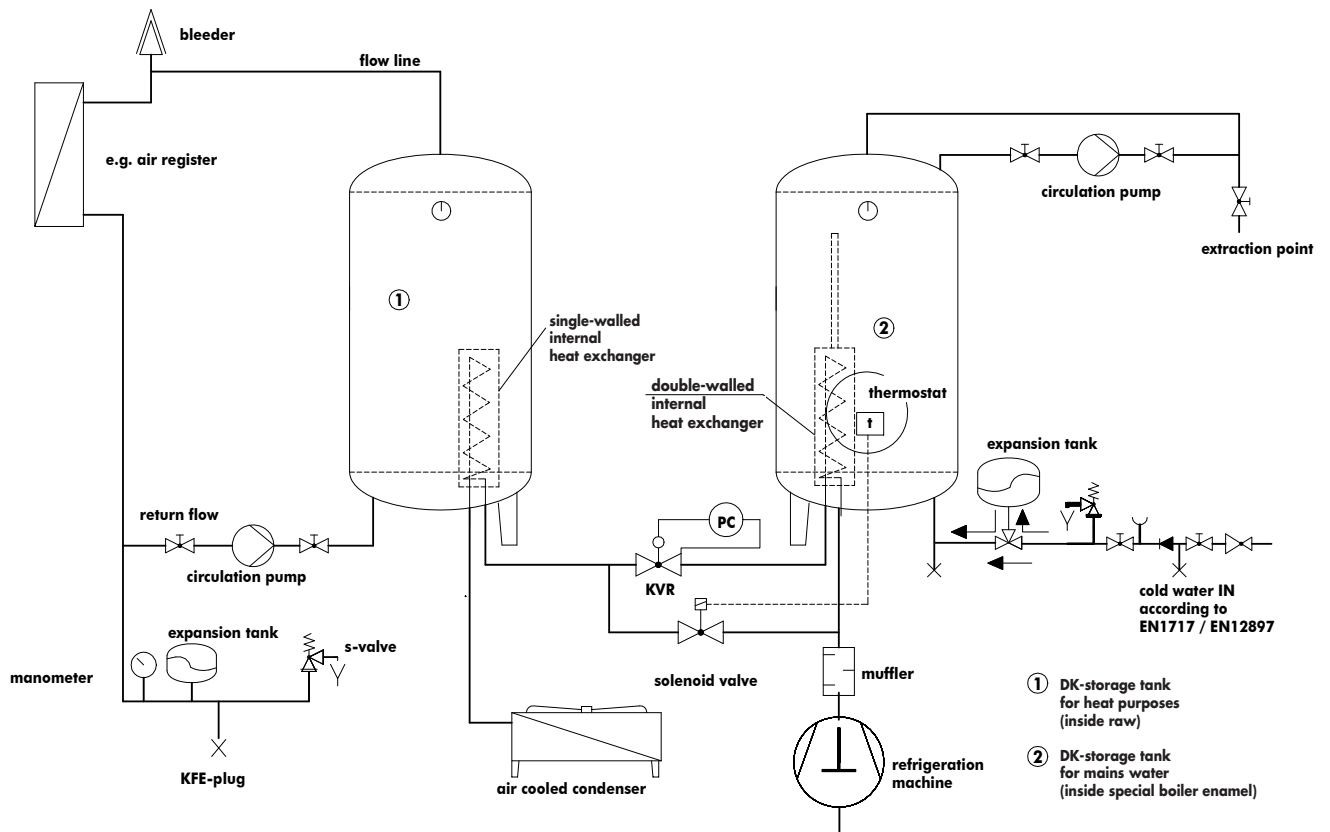



Cooling. Heating.  
Innovation.

## Paralleling water-carrying side of DK-Heat Recovery

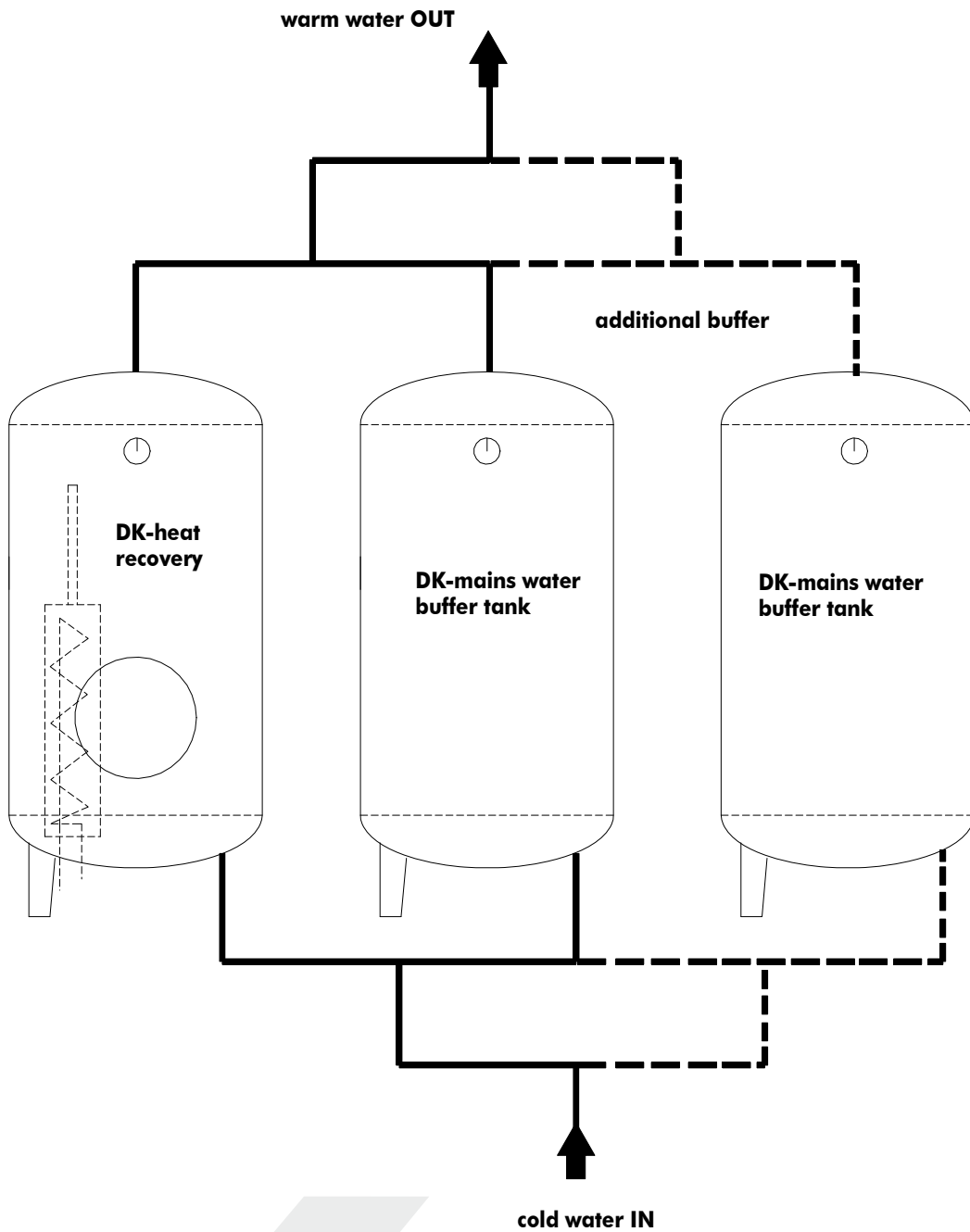



Cooling. Heating.  
Innovation.

## DK-Buffer tank with attached tubular desuperheater

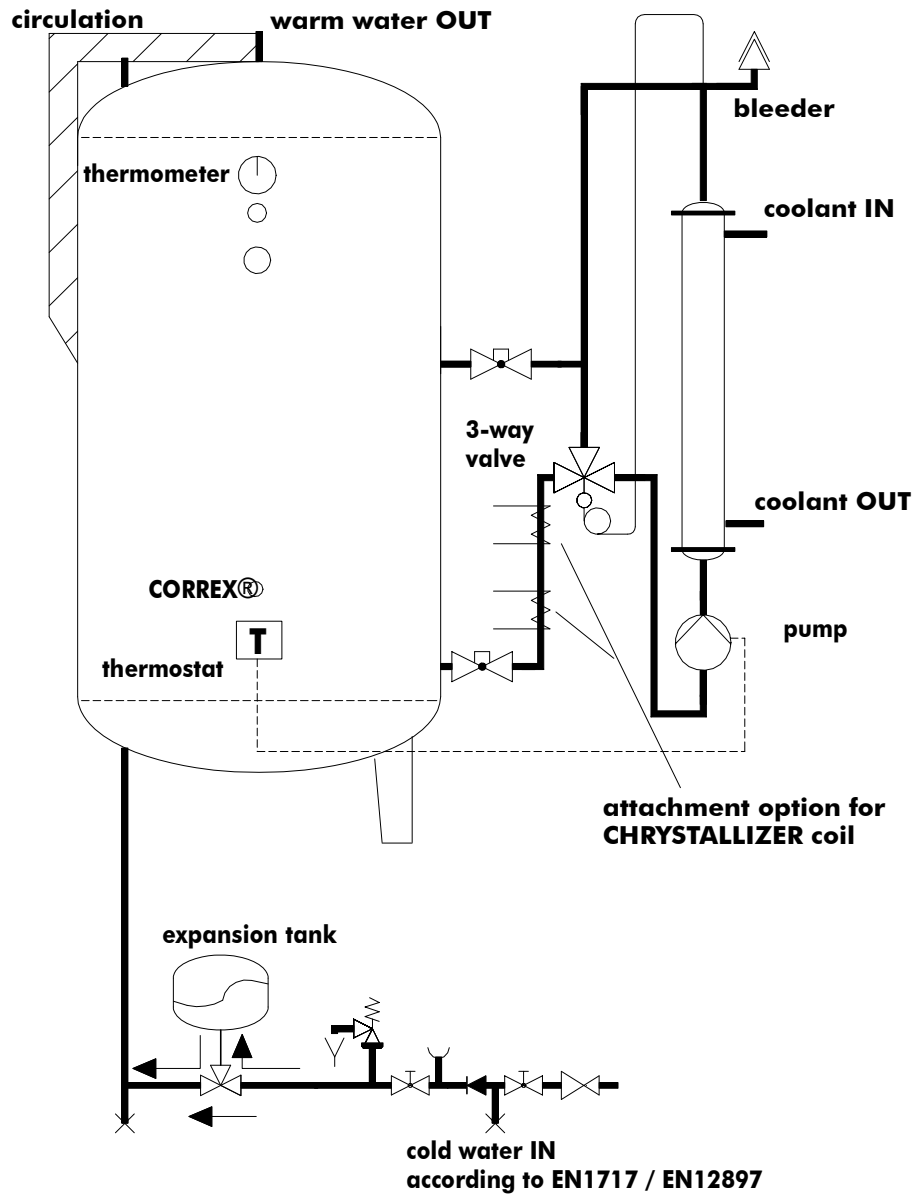



Cooling. Heating.  
Innovation.

## DK-Buffer tank with separate tubular desuperheater

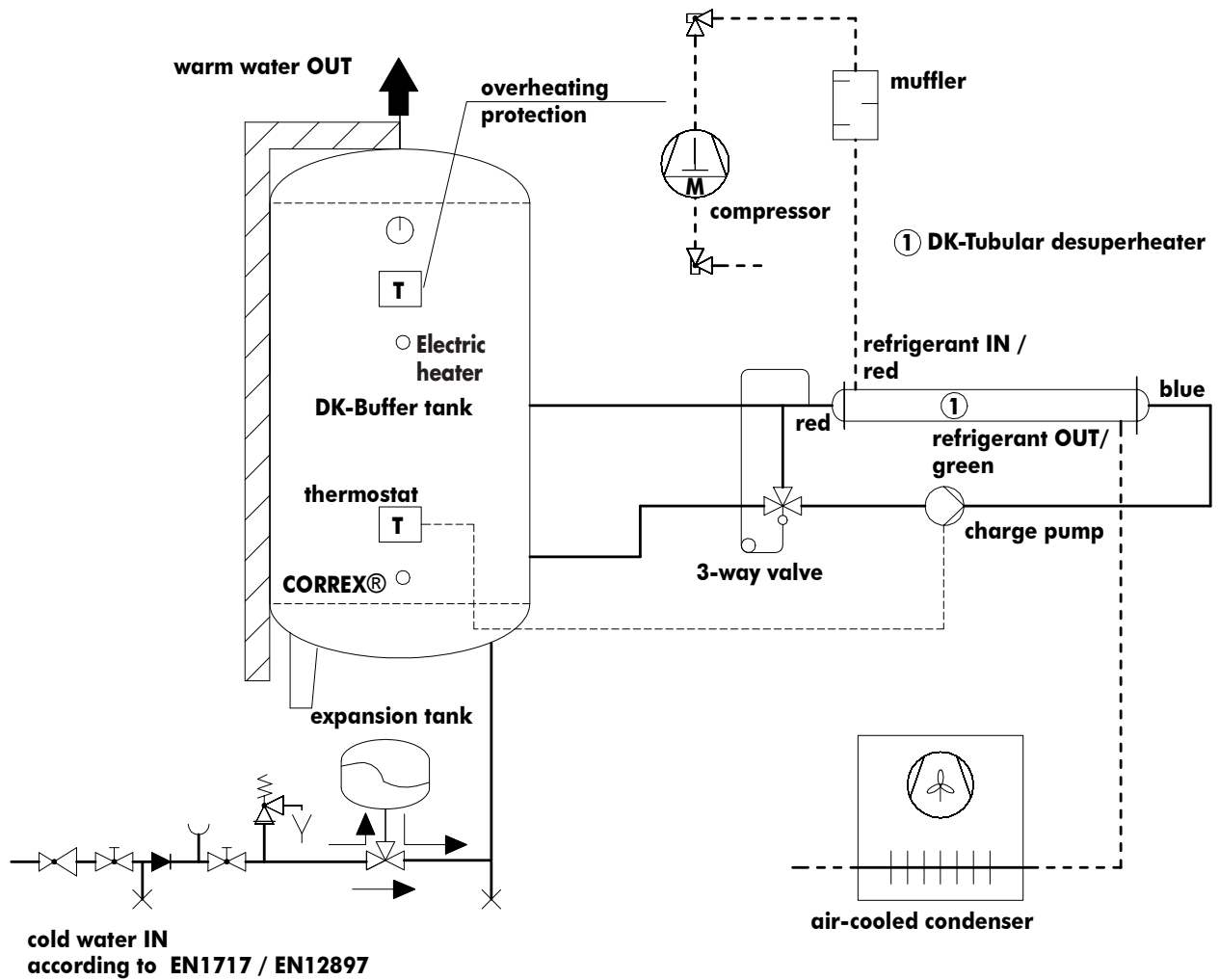



Cooling. Heating.  
Innovation.

## DK-Buffer tank with two separate tubular desuperheaters

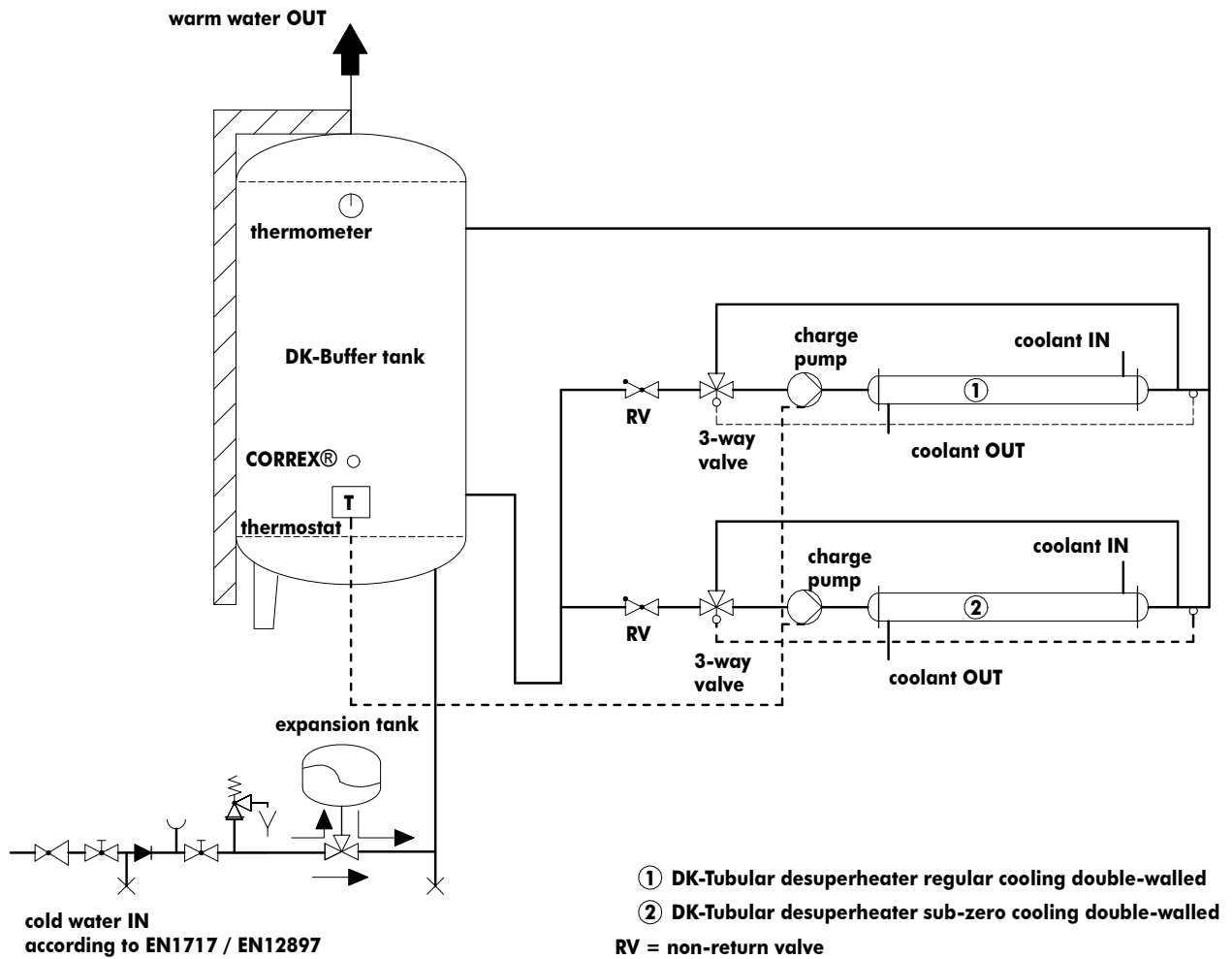



Cooling. Heating.  
Innovation.

## Paralleling of two buffer tanks with separate tubular desuperheater

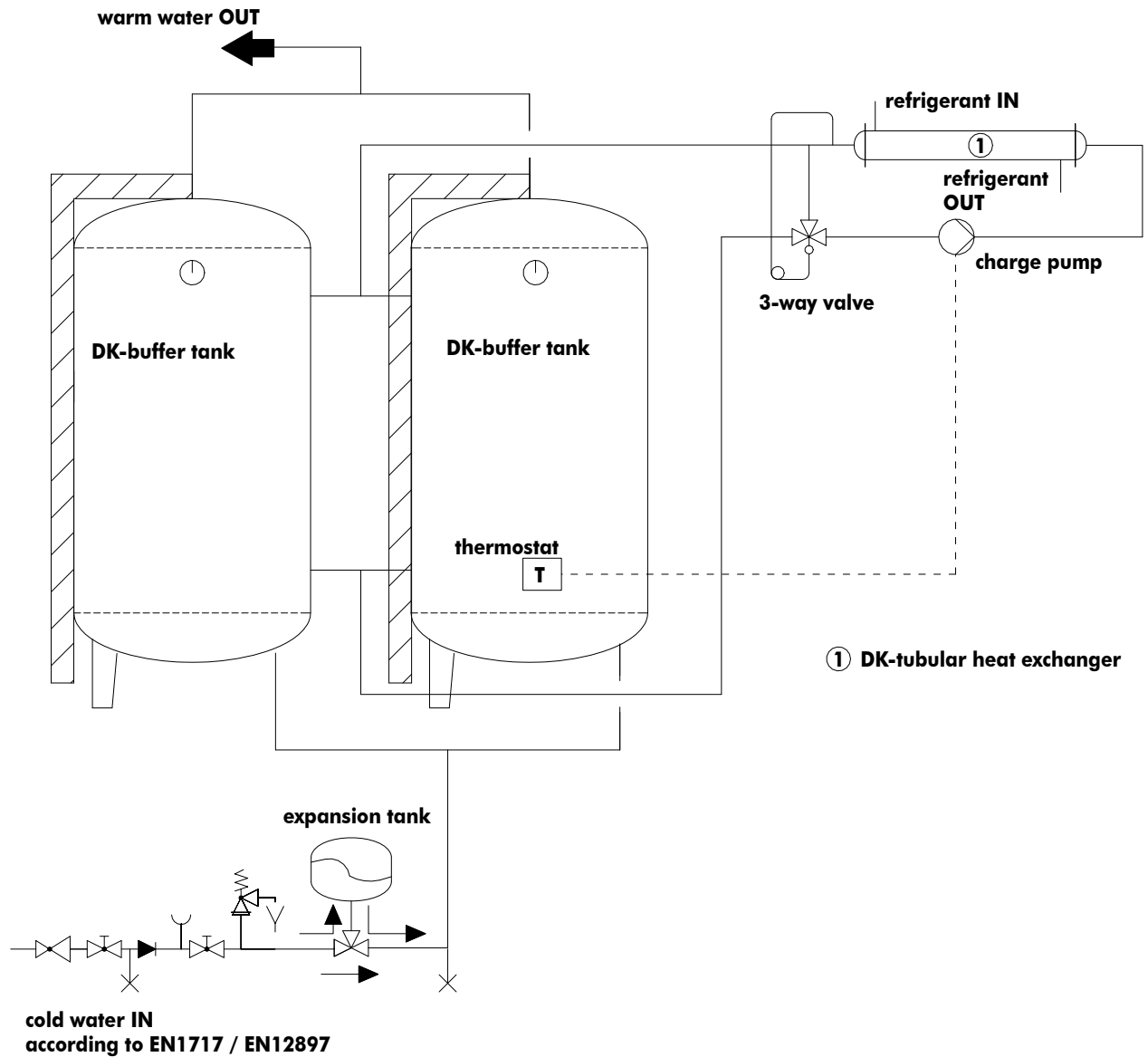



Cooling. Heating.  
Innovation.

## DK-Tubular Condenser with attached Pump

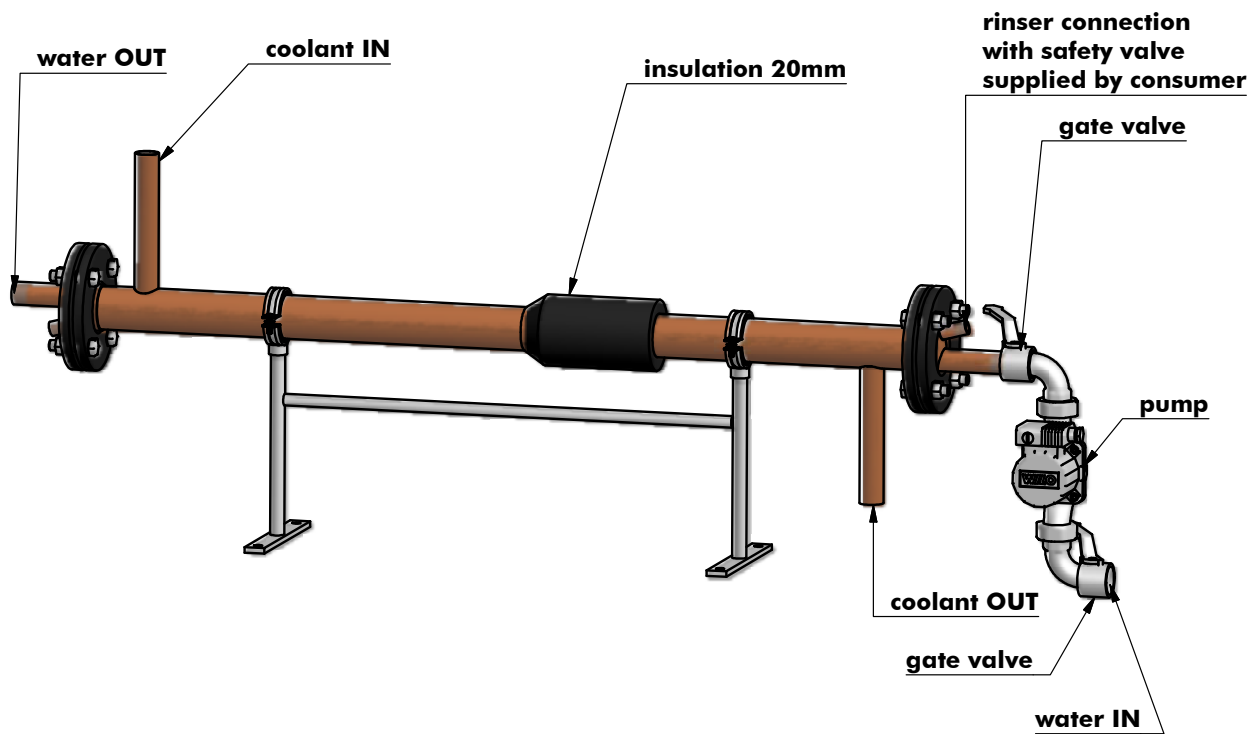

## DK-Tubular Desuperheater with attached Pump and 3-Way Valve

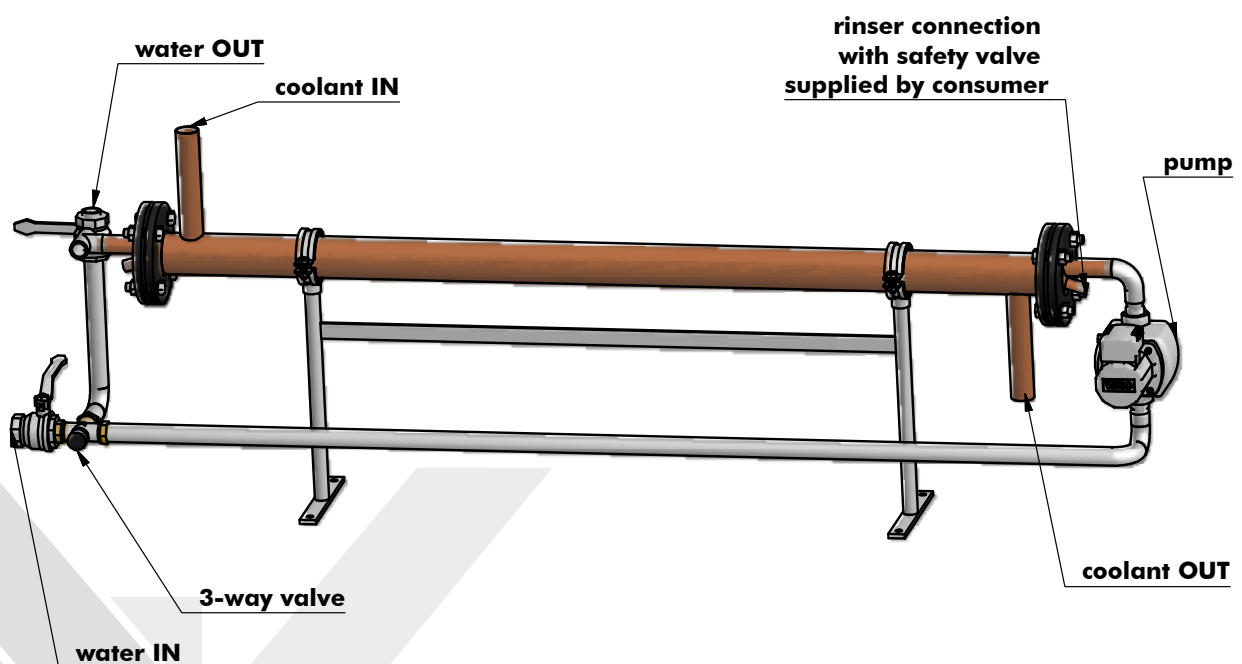



Cooling. Heating.  
Innovation.

## DK-Suction Gas Heat Exchanger

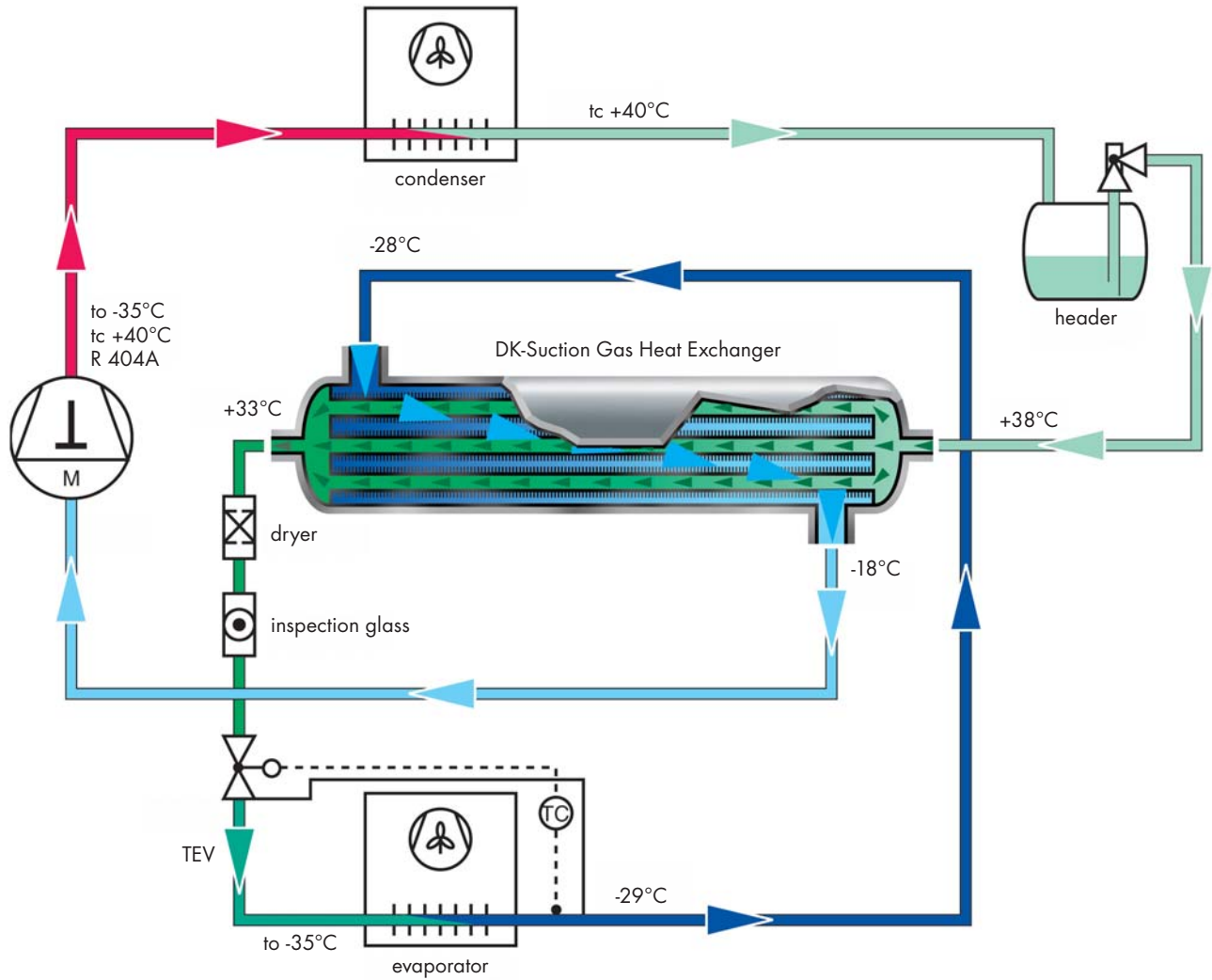





## Description of Suction Gas Heat Exchanger

DK-Suction Gas Heat Exchangers ensure the safety of the condenser and optimise the capacity of the refrigeration unit with a precision-degree valuation of the liquid subcooling and suction gas overheating of the refrigeration units.

### Improved Performance of the Refrigeration Unit

DK focuses on all activities related to the planning and manufacturing of components that aim at improving the performance balance of refrigeration units. Certain refrigerants – especially R404A – allow for a performance gain from subcooling the liquid that exceeds the performance loss following superheating of the suction gas, due to a larger volume. Subcooling the liquid by 10 K in a refrigeration unit to -10°C produces an increased output of approx. 10%. Other refrigerants, such as R134a, produce a smaller performance gain. The following *BITZER* table for the condenser model 4DC-5.2Y (or 4DC-7.2Y) exemplifies these relevant correlations. The table states the changes in performance during subcooling at 5, 10 and 15 K. When subcooling 10 K to -10/1c +45°C the evaporator produces a 9.2%-higher output. Very important here is that the rise in the pressure gas temperature is taken into consideration.

	Suction gas temperature at compressor inflow	Cooling performance compressor (EN 12900)	Cooling performance compressor	Cooling performance evaporator (7K useable superheating)	Coefficient of performance at evaporator	Percent additional performance evaporator	Discharge temperature
<b>Refrigerant R404A/R507A, Normal cooling -10°C/45°C</b>							
No HX	2 °C	13.12 kW	12.06 kW	11.54 kW	1.85	-	78 °C
5K subcooling	11.22 °C	13.12 kW	13.57 kW	12.08 kW	1.93	4.7	86.9 °C
10K subcooling	20.07 °C	13.12 kW	14.93 kW	12.60 kW	2.02	9.2	95.5 °C
15K subcooling	28.61 °C	13.12 kW	16.21 kW	13.09 kW	2.09	13.4	103.8 °C
<b>Refrigerant R404A/R507A, Deep freezing -35°C/40°C</b>							
No HX	-15 °C	4.25 kW	3.65 kW	3.27 kW	1.01	-	100.5 °C
5K subcooling	-5.22 °C	4.25 kW	4.10 kW	3.45 kW	1.07	5.5	110.5 °C
10K subcooling	4.12 °C	4.25 kW	4.51 kW	3.62 kW	1.12	10.7	120 °C
15K subcooling	13.09 °C	4.25 kW	4.90 kW	3.78 kW	1.17	15.6	129 °C
<b>Refrigerant R134a, Air condition 5°C/50°C</b>							
No HX	15 °C	14.11 kW	13.97 kW	13.69 kW	3	-	77.1 °C
5K subcooling	23.48 °C	14.11 kW	14.95 kW	13.92 kW	3.05	1.7	85.6 °C
10K subcooling	31.78 °C	14.11 kW	15.87 kW	14.16 kW	3.1	3.4	94.1 °C
<b>Refrigerant R134a, Normal cooling -10°C/45°C</b>							
No HX	2 °C	7.86 kW	7.59 kW	7.35 kW	2.16	-	82.8 °C
5K subcooling	10.81 °C	7.86 kW	8.12 kW	7.49 kW	2.2	1.9	92 °C
10K subcooling	19.41 °C	7.86 kW	8.62 kW	7.62 kW	2.24	3.7	101 °C
15K subcooling	27.8 °C	7.86 kW	9.09 kW	7.75 kW	2.28	5.4	109.7 °C
<b>Refrigerant R407C, Compressor 4DC-7.2Y, Air condition 5°C/50°C Dew points</b>							
No HX (t <sub>liquid</sub> = 45,4°C)	15 °C	20.2 kW	19.95 kW	19.58 kW	2.94	-	86.8 °C
5K (t <sub>liquid</sub> = 40,4°C)	23.83 °C	20.2 kW	21.4 kW	19.98 kW	3	2	95.7 °C
10K (t <sub>liquid</sub> = 35,4°C)	32.43 °C	20.2 kW	22.8 kW	20.4 kW	3.06	4.2	104.2 °C

Nov. 2002: Date based on Bitzer Software 3.3



**Cooling. Heating.  
Innovation.**

When operating a refrigeration unit with a thermo-controlled expansion valve, the evaporator is pre-set to overheating at 6 K, to ensure complete evaporation. This entails that only 85% of the evaporator surface instead of the entire evaporator is used for the actual evaporation of the refrigerant, while 15% of the evaporator surface are required to achieve overheating.

With the DK-Suction Gas Heat Exchanger, overheating in the evaporator can be set with an electronic expansion valve as low as possible and the probe of the expansion valve can be placed, as usual, at the end of the evaporator. And even when operating a thermo-controlled expansion valve operation is possible without overheating in the evaporator. The suction gas heat exchanger is then to be mounted directly at the evaporator's outlet and the probe of the expansion valve at the outlet of the suction gas heat exchanger.

The evaporator can thus be used 100%. When using an evaporator of the same capacity, a higher evaporation temperature thus produces the same refrigeration output. This is one of the main energetic advantages of the DK-Suction Gas Heat Exchanger.

### **Condenser Safety**

A major advantage of the Suction Gas Heat Exchanger is the optimal safety of the condenser. All condenser manufacturers welcome an increase in the suction gas temperature. The raised temperature prevents the oil in the condenser from cooling excessively, which is beneficial to the condenser's lubrication. Also, the DK-Suction Gas Heat Exchanger can eliminate so-called liquid slugging. This added safety feature for the condenser is achieved by completely evaporating all liquid particles contained in the suction gas heat exchanger.

### **Additional Advantages**

A particularity of the DK-Suction Gas Heat Exchanger is the precision-degree calculation of the liquid subcooling and suction gas superheating. This seems very important for us since, although excessive subcooling leads to an increase of the energetic benefit, it also raises the condenser's final temperature which, if too high, is known to cause the condenser to fail. A further advantage of the DK-Suction Gas Heat Exchanger is to be seen in the fact that a precision calculation of the number of inner tubes required inside the shell tube results in a balanced ratio of available surface for suction gas- and liquid-carrying lines; paired with the special mountings of the inner tubes completes the reasons why the DK-Suction Gas Heat Exchanger runs without a noteworthy loss of pressure in gas-carrying as well as liquid-carrying lines.

Our complete program supplies DK-Suction Gas Heat Exchangers with suction line connections ranging between 28 and 133 mm, as well as liquid line connections ranging from 16 to 64 mm.





## Design of a compressor with/without DK-Suction Gas Heat Exchanger

Design with the aid of the BITZER software

### without DK-Suction Gas Heat Exchanger

Default values	
<b>Type of condenser</b>	<b>4DC -5.2Y -40S</b>
Refrigerant	R404A
Reference temperature	Dew point
Evaporation	-10° C
Condensation	45° C
Liquid sub-cooling	0K
Suction gas temperature	2° C
Grid supply	400V -3 -50Hz
Usable overheating	7.00K
Output regulator	100%

### with DK-Suction Gas Heat Exchanger

Default values	
<b>Type of condenser</b>	<b>4DC -5.2Y -40S</b>
Refrigerant	R404A
Reference temperature	Dew point
Evaporation	-10° C
Condensation	45° C
Liquid sub-cooling	10K
Suction gas temperature	20° C
Grid supply	400V -3 -50Hz
Usable overheating	7.00K
Output regulator	100%

Result	
<b>Type of condenser</b>	<b>4DC -5.2Y -40S</b>
Refrigeration capacity	12.08 kW
Refrigeration capacity*	13.12 kW
Evaporation capacity	11.54 kW
Power consumption	6.25 kW
Power (400V)	10.89 A
Voltage range	380 -420V
Condensation capacity (with WA)	18.02 kW
Performance number	1.93
Performance number*	2.10
Mass flow rate	421 kg/h
Type of operation	Standard

Result	
<b>Type of condenser</b>	<b>4DC -5.2Y -40S</b>
Refrigeration capacity	14.93 kW
Refrigeration capacity*	13.12 kW
Evaporation capacity	12.60 kW
Power consumption	6.25 kW
Power (400V)	10.89 A
Voltage range	380 -420V
Condensation capacity (with WA)	19.06 kW
Performance number	2.39
Performance number*	2.10
Mass flow rate	393 kg/h
Type of operation	Standard

**It quickly emerges that the same power draw reaches an improvement of the refrigeration capacity of the condenser of 11.54 kW to 12.6 kW = 1.04 kW = 9.2%.**

\* according to EN 12900  
(20° C Suction gas temperature / 0 K Liquid sub-cooling)

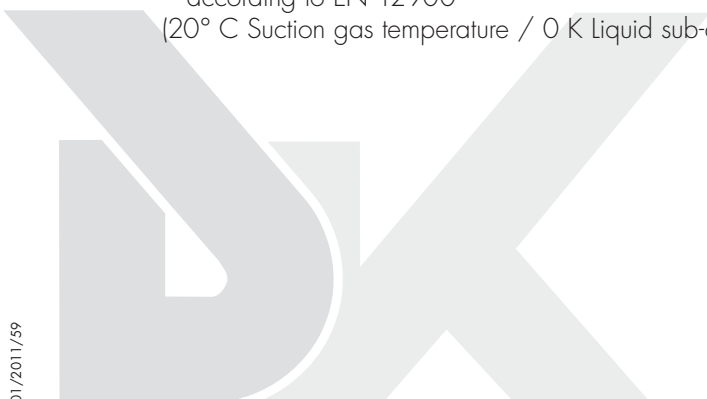



## Overview of DK-Suction Gas Heat Exchangers (1.0 m)

The following table itemizes the range of standard DK-Suction Gas Heat Exchangers: (1.0 m length of exchanger) model 42/3x13 to model 219/64x13 = 9 designs with liquid connections ranging between 12 and 64 mm and suction gas connections between 28 and 133 mm.

Type	External pipe (mm)	Internal tubes	Length of internal tubes (mm)	Distance mounting (mm)	Total length (mm)	Total height (mm)	Suction line (mm)	Liquid line (mm)	Surface LP side (m <sup>2</sup> )	Capacity of heat exchanger (W) <sup>1)</sup>	Content of outer pipe area (LP side) in dm <sup>3</sup>	Content of tube area (HP side) in dm <sup>3</sup>	Weight (kg/m)	Weight (kg per 0,1 m)
42/3x13	42	3x13	1,000	500	1,500	360	28	16	0.48	1,550	0.8	0.26	5	0.5
54/5x13	54	5x13	1,000	500	1,500	370	35	18	0.8	2,590	1.3	0.35	9	0.5
64/7x13	64	7x13	1,000	500	1,500	380	42	22	1.12	3,620	1.9	0.5	13	1
76/9x13	76	9x13	1,000	500	1,500	400	54	22	1.44	4,665	2.8	0.6	17	1
89/12x13	89	12x13	1,000	500	1,500	420	64	28	1.92	6,220	4.0	0.8	22	2
108/20x13	108	20x13	1,000	500	1,550	450	76	35	3.2	10,360	5.5	1.3	33	3
133/30x13	133	30x13	1,000	500	1,550	480	89	42	4.8	15,550	8.3	2.0	41	4
159/40x13	159	40x13	1,000	500	1,550	500	108	54	6.4	20,700	12.4	2.8	52	5
219/64x13	219	64x13	1,000	500	1,600	560	133	64	10.24	33,100	26.1	4.8	87	6

Those who are more familiar with the DK range will see parallels of the DK-Suction Gas Heat Exchanger with the single-walled tubular condensers and will notice that the tubular condensers accommodate many more tubes of the same type in the jacket tube.

### Examples:

- **DK-Tubular Condenser Type 159/50x13 = 50 tubes**
- **DK-Suction Gas Heat Exchanger Type 159/40x13 = 40 tubes**

The number of tubes for the suction gas heat exchangers in conjunction with the aforementioned tube pieces for the mounting has been calculated as such that it results in a free cross section in parallel with the suction gas connection (in this case 108 mm) and with the liquid connections of 54 mm.

It is not the maximum number of tubes that count or the maximum area, but the number of tubes required for the smooth operation of the refrigeration installation without any major loss of pressure.

Max. operating pressure: outer pipe area (OA) 16 bars - tube area (TA) 30 bars

1) Capacity quoted for R404A installation conditions:

Normal cooling refrigeration units: Subcooling of liquid from +40°C to +30°C - overheating of suction gas from ±0°C to +20°C

Deep freezing refrigeration units: Subcooling of liquid from +40°C to +35°C - overheating of suction gas from -25°C to -15°C



Cooling. Heating.  
Innovation.

## DK-Water Chiller with evaporator

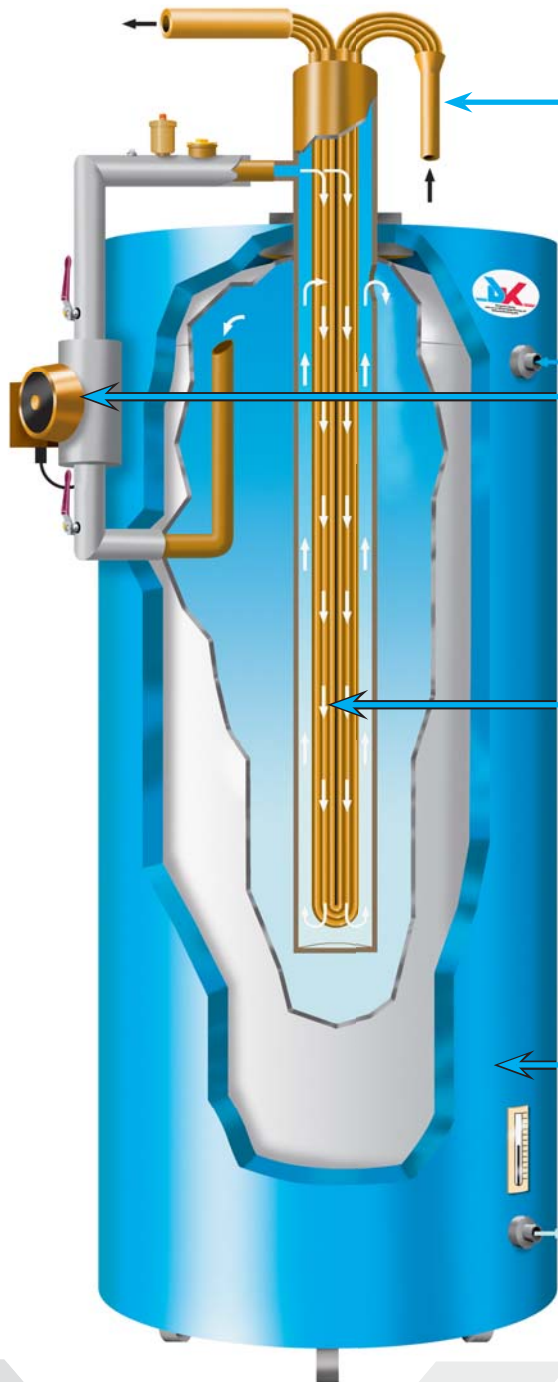

### Venturi distributor

Optimal dissipation of liquid

### Charge pump

For charging the storage tank

### Evaporator

Double walled for cooling mains water  
Single walled for cooling water  
Built in the storage tank

### Storage tank

Storage tank for cooling mains water:  
With inside special boiler enamel  
Storage tank for cooling water:  
Inside raw

Insulation out of PU foam insulation



## Information

### Description of the DK-Water Chiller

Similar as with the design of the DK-Heat Recovery unit (container with internal heat exchangers) the typical DK-Water Chiller consists of a container with a built-in evaporator, i.e. a combination of buffer and evaporator.

The only thing you have to do is to connect the fluid and the suction line of the refrigerating plants to the DK-Water Chiller and to establish the water connection to the consumers.

The DK storage tanks for open water systems (with oxygen supply) are enamelled, while closed water systems are equipped with „raw“ storage basins. Cold water containers with a capacity of 180, 280, 400, 700 and 950 l are supplied by DK isolated as steam diffusion proof containers. In the case of bigger containers, there is the risk that a prefabricated isolation is damaged during the transport, the integration and the assembly so that the steam diffusion resistance might no longer be ensured. Thus, larger containers will be supplied without insulation and must be separated on site following their installation.

### Description of the DK-KS-Evaporator

In the case of the DK-Water Chiller, the KS evaporators are equipped with a very complex fluid distribution unit and interconnected on the suction side. In addition, the precise guidance of the refrigerant is obtained by using bends at the opposite side. The result is an almost 100% even distribution of refrigerants to the single tubes, so that one can assume that the temperatures inside all tubes are the same. This is a prerequisite of a trouble-free operation with evaporation temperatures below zero and water temperatures near the around freezing point.

The DK-KS evaporator is also available with an additional flange to facilitate the removal of the housing in order to clean the evaporator without any problems. So, nothing stands in the way of the use of the DK water cooler with unclean media.

## Insulation

### DK-Water Chiller Tank

DK-PU foam insulation, 2 half-shells	s=55mm
Building material class:	DIN 4102/B3
Colour ton:	RAL 5017 blue
Thermal conductivity $\lambda$ (lambda):	0.036W/mK at +0°C
Application range:	-20°C to +105°C

### Shell-and-tube evaporator, liquid cooler, copper pipes Kaiflex KK®

Building material class:	DIN 4102 B2, self-extinguishing as per ASTM D 635-81
Thermal conductivity $\lambda$ (lambda):	0.04 W/mK at +40°C
Application range:	-57°C to +125°C
Diffusion of vapour resistance:	> 4000 $\mu$ (DIN 52615)



## **Application examples**

### **Typical application areas of the DK-Water Chiller**

- Air conditioning systems with temperatures +12/+6°C
- General process cooling plants +8/+4°C or +15/+10°C
- Asparagus cooling +6/+1°C
- Indirect cooling using glycol systems, e. g. -8/-4°C
- Deep-freeze systems -32 / -28°C
- Special plants such as oil cooling -50°C

### **Indirect cooling using glycol systems -8/-4°C**

Today, indirect cooling is already frequently used for ripening processes for instance of ham, since such processes require a fixed change between warmth and cold. Hot brine and cold brine are used in just one heat transfer system. The result is an ideal combination also for the DK-Heat Recovery system, because while some ripening cells are treated with cold brine, others can be treated with hot brine, heated by the DK-Heat Recovery device.

During the last few years the largest indirect cooling plants ever made by DK have been supplied to airport catering companies including, among others, a plant with a refrigerating capacity of 1,800 kW, -8/-4°C for normal cooling with 4 evaporators in a 12,000 l tank.

Here, the deep freezing plants are also operated with cold brine (Qo ca. 250kW, -32/-28°C).

In the case of large branched refrigeration systems, the DK-Water Chiller offers the advantage that the cold can be distributed within a hydraulic system. Such plants are shown in the pictures below.



### **Bakery / Cool water dough production**

**The DK-Water Chiller has gained a good reputation also in the bakery and baking goods trade where enamelled containers which are isolated in a steam-tight manner with a capacity of 950 l with double-walled evaporators.**

Especially in the dough production for white bread using common rapid kneading machines and warm additives during the summer, the dough heats up very quickly and the fermentation process starts prior to the designated point of time. For this reason, so-called dough cooling devices are used at water temperatures of +2°C. Since this water gets into the dough directly, the fact that the evaporator is double-walled is a big bonus and a good sales argument. In the course of the years, a DK range of plants has emerged that is able to supply cold water from 100 to 1,000 l per hour - cooling the water down from + 18 to +2°C.

**The equipment of salad washing plants with DK water coolers follows the same principle, since salad remains fresh for a considerably longer time when washed at below +4°C.**



## Technical data:

Type	External pipe (mm)	Internal tubes	Clear surface area of water (mm <sup>2</sup> )	Water connection max.	Refrigerant (mm <sup>2</sup> )	Refrigerant connection max. (mm)	Surface area of refrigerant (m/m <sup>2</sup> )	Total length: calculated length of finned tubes plus:
------	--------------------	----------------	--	-----------------------	--------------------------------	----------------------------------	---	---

### DK-KS tubular evaporator

- integrated in a copper housing in the case of open systems with oxygen supply
- integrated in steel housing in the case of closed systems without oxygen supply
- built-in in the tank

<b>54/4 x 15 KS</b>	54	4 x 15	1,189	¾ "	218	18	0.288	0.2
<b>64/6 x 15 KS</b>	64	6 x 15	1,665	1 "	327	22	0.432	0.2
<b>76/8 x 15 KS</b>	76	8 x 15	2,299	1 "	436	28	0.576	0.2
<b>89/14 x 15 KS</b>	89	14 x 15	2,700	1¼ "	763	35	1.008	0.2
<b>108/20 x 15 KS</b>	108	20 x 15	4,299	1½ "	1,090	42	1.44	0.3
<b>133/32 x 15 KS</b>	133	32 x 15	6,273	2 "	1,744	54	2.304	0.3
<b>159/48 x 15 KS</b>	159	48 x 15	8,615	2½ "	2,616	64	3.456	0.3
<b>219/92 x 15 KS</b>	219	92 x 15	16,496	80 DN	5,014	89	6.624	0.36
<b>267/128 x 15 KS</b>	267	128 x 15	35,047	100 DN	6,976	108	9.216	0.45

### DK-KS tubular evaporator for closed water systems

- integrated in steel housing, insulated in a steam-tight manner, including holders
- built-in in the tank

<b>219/92 x 15 KS</b>	219	92 x 15	16,496	80 DN	5,014	89	6.624	0.36
<b>273/128 x 15 KS</b>	273	128 x 15	35,047	100 DN	6,976	108	9.216	0.45
<b>400/216 x 15 KS</b>	400	216 x 15	91,499	150 DN	11,772	133	15.552	0.66
<b>400/256 x 15 KS</b>	400	256 x 15	83,755	150 DN	13,952	133	18.432	0.66

### DK tubular evaporator in double-wall safety version

Evaporator integrated into enamelled reservoir made for the water cooling for direct food production

<b>64/4 x 16/10</b>	64	4 x 16/10	1,627	1¼ "	100	12	0.76	0.2
<b>76/6 x 16/10</b>	76	6 x 16/10	2,281	1¼ "	150	16	1.14	0.2
<b>89/10 x 16/10</b>	89	10 x 16/10	2,552	1¼ "	251	18	1.90	0.2
<b>108/14 x 16/10</b>	108	14 x 16/10	4,612	1¼ "	352	22	2.66	0.3
<b>133/20 x 16/10</b>	133	20 x 16/10	6,489	1½ "	502	28	3.80	0.3
<b>159/28 x 16/10</b>	159	28 x 16/10	16,256	1½ "	703	35	5.32	0.4
<b>219/48 x 16/10</b>	219	48 x 16/10	19,959	2 "	1.206	42	9.12	0.4
<b>267/72 x 16/10</b>	267	72 x 16/10	35,126	3 "	1.809	54	13.68	0.5





## Refrigerant injection/load per tube

When calculating the evaporators, it is not only the area that is decisive. Of major importance are the refrigerant volumes per tube. The injection of the refrigerant plays a particular role. Depending on the type of refrigerant used, different outputs per tube can be reached.

Coolant	Injection 6 x 0.8 mm	Injection 7 x 0.9 mm
R404A / R507A	1.9 kW/tube	2.9 kW/tube
R134a	2.4 kW/tube	3.6 kW/tube
R407C / R22	3.0 kW/tube	4.2 kW/tube

### Example:

The largest evaporator is the model 400/256x15KS

Jacket tube: 400 mm diameter

Inner tube: 256 pcs

The simple deflection results in a 128-fold injection ( $256/.2 = 128$ ).

When using R404A and injection lines 7 x 0.9 mm the maximum output per tube totals 2.9 kW.

max. output of heat exchanger:  $128 \text{ (tubes)} \times 2.9 \text{ (kW/tube)} = 371.2 \text{ kW}$

When using the refrigerant R407C or R22 the maximum load per tube is 4.2 kW, so that a maximum refrigeration output of 537.6 kW can be reached.





Cooling. Heating.  
Innovation.

## DK-Water Chiller Type 180 to 950, standing design

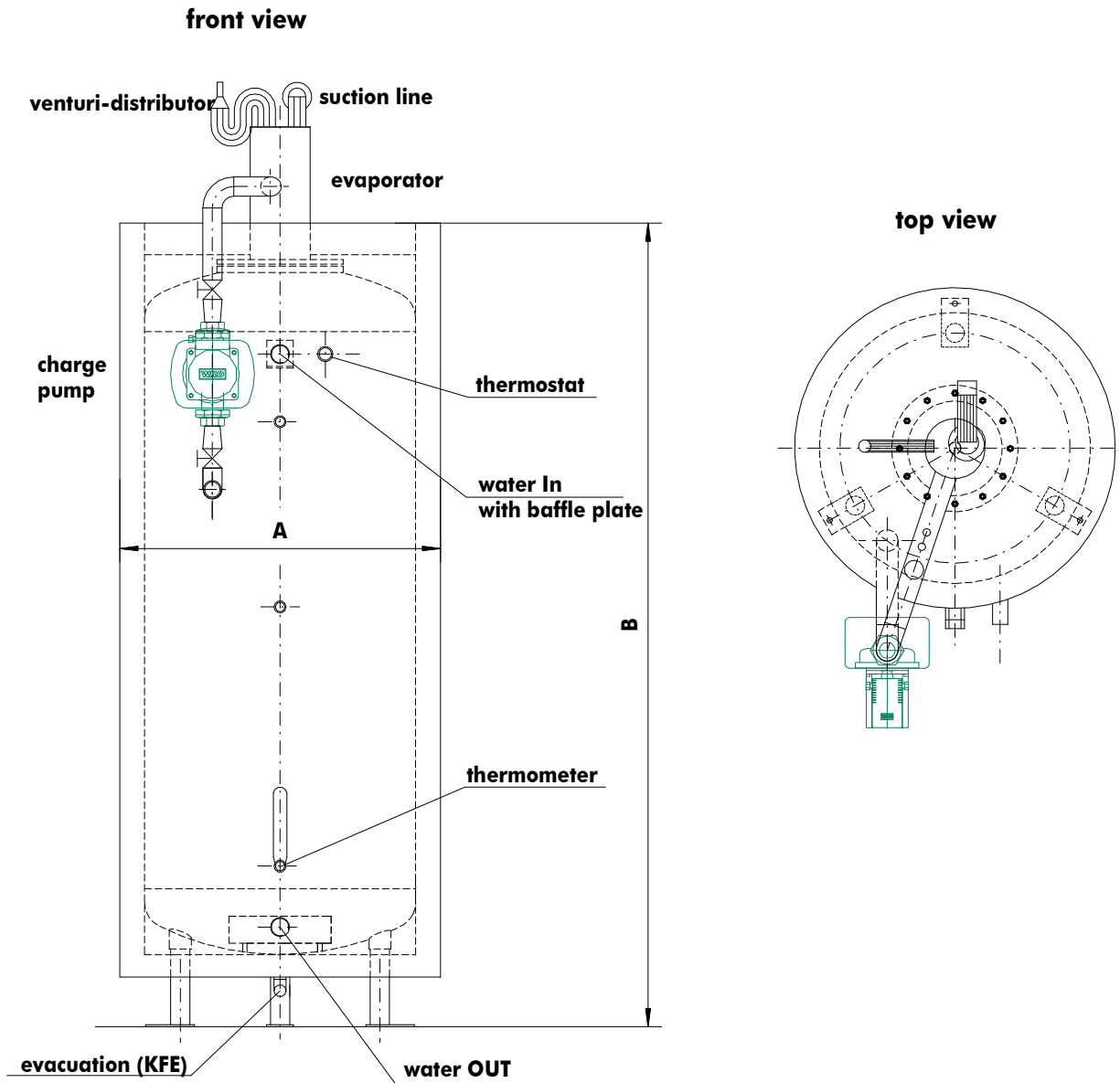

Insulation:  
55 mm PU foam  
sealed against diffusion of vapor

### Table of dimensions

	180	280	400	700	950
A	610	710	710	860	860
B	1320	1270	1760	1970	2490



Cooling. Heating.  
Innovation.

# DK-Water Chiller Type 180 to 950, lying design

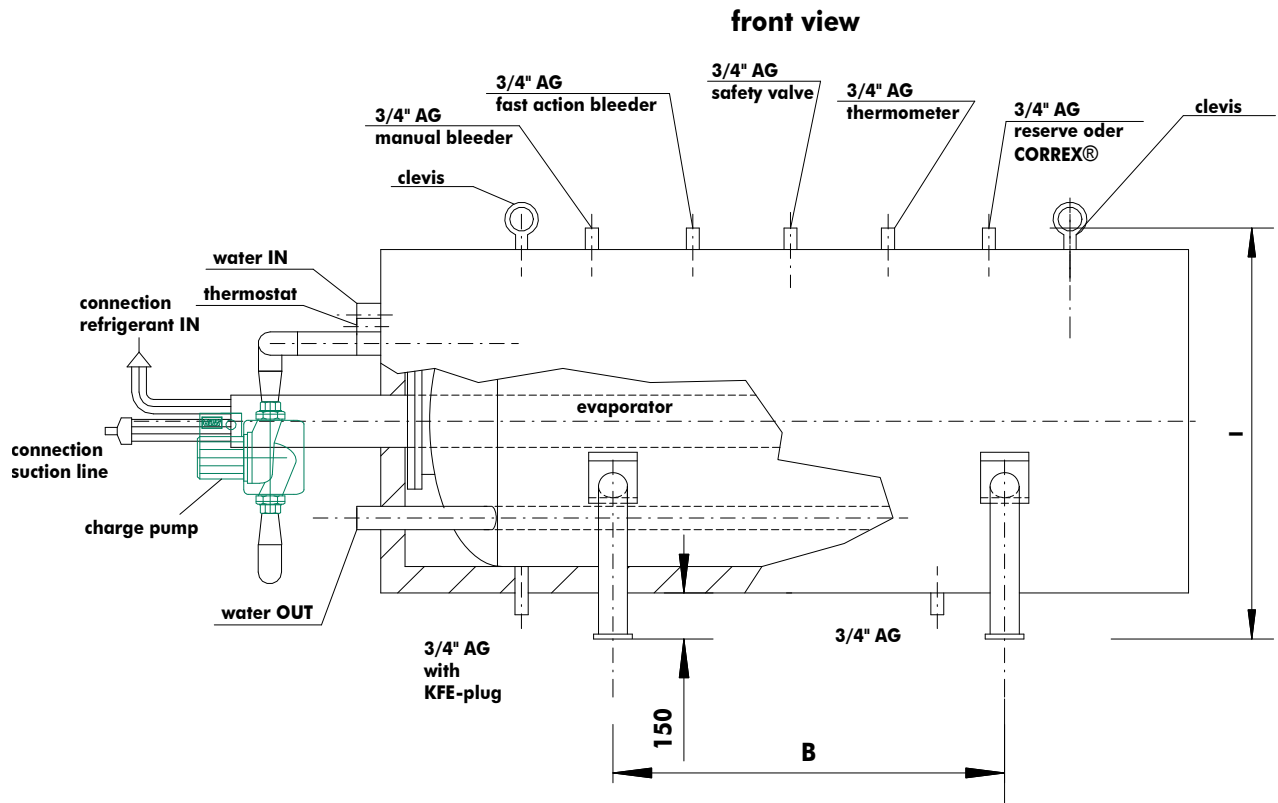

**side view from left**

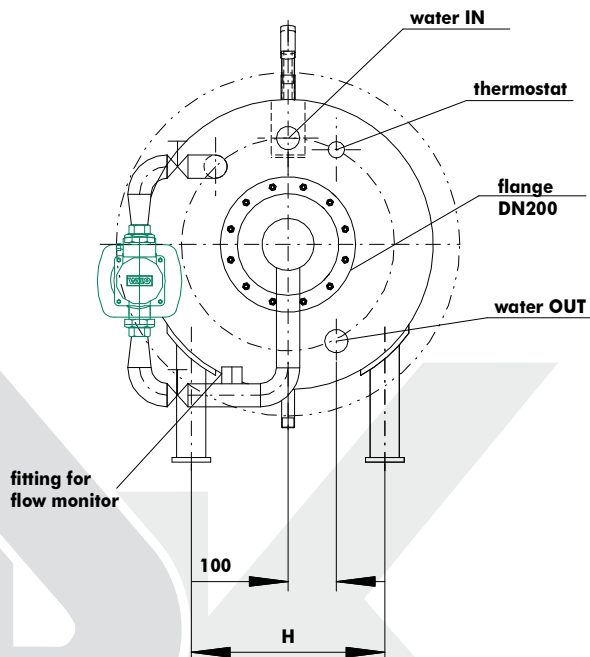

**Table of dimensions**

	180	280	400	700	950
ø	610	710	710	860	860
B	430	480	810	1090	1500
G	1230	1180	1670	1890	2400
H	350	400	400	500	500
I	810	910	910	1060	1060
I = Height plus installation parts					



Cooling. Heating.  
Innovation.

# DK-Cold water buffer tank Type 180 to 950, standing design

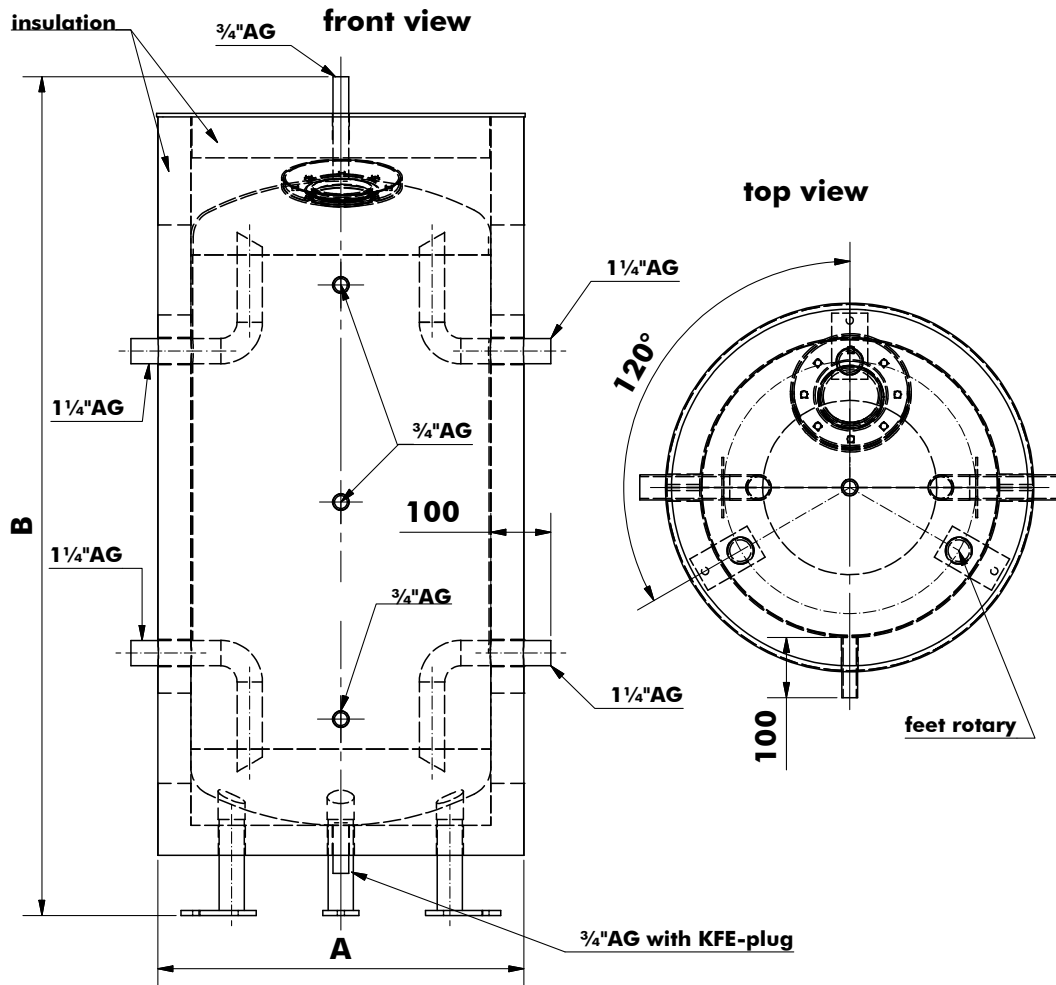

base plate  
60x110 (180-400l)

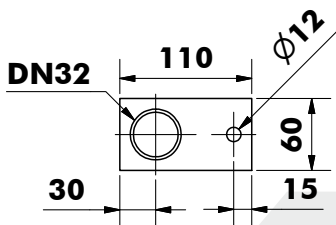

base plate  
80x140 (700+950l)

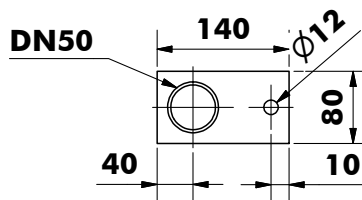

Table of dimensions

	180	280	400	700	950
A	610	710	710	860	860
B	1410	1350	1850	2100	2580



Cooling. Heating.  
Innovation.

## DK-Cold water buffer tank 1000 – 10.000 Liter

Chilled water buffer (range of application up to -20C°) **without insulation** for 6 bar operating pressure; inside raw; outside with 2-component primer; featuring 4 connections for primary and secondary circuits à 2", as well as 3 x 3/4" inside the vessel's shell (top/centre/bottom) and evacuation/venting each 1", incl. chilled water thermometer; excl. of TÜV approval. Production certificate supplied.

### Available dimensions

Order number	Content	Diameter	Height
10170	1,000 l	900 mm	2,000 mm
10171	1,500 l	900 mm	2,580 mm
10172	1,500 l	1,000 mm	2,250 mm
10173	2,000 l	1,100 mm	2,450 mm
10174	2,000 l	1,200 mm	2,050 mm
10175	2,500 l	1,200 mm	2,450 mm
10176	3,000 l	1,200 mm	2,800 mm
10177	3,000 l	1,300 mm	2,680 mm
10028	4,000 l	1,300 mm	3,450 mm
10028	4,000 l	1,500 mm	2,700 mm
10028	5,000 l	1,500 mm	3,200 mm
10028	5,000 l	1,600 mm	2,950 mm
10028	5,000 l	1,800 mm	2,430 mm
10028	6,000 l	1,800 mm	2,840 mm
10028	7,000 l	1,800 mm	3,250 mm
10028	7,000 l	2,000 mm	2,750 mm
10028	8,000 l	2,000 mm	3,070 mm
10028	8,000 l	2,200 mm	2,650 mm
10028	9,000 l	2,000 mm	3,390 mm
10028	9,000 l	2,200 mm	2,910 mm
10028	10,000 l	2,000 mm	3,710 mm
10028	10,000 l	2,200 mm	3,180 mm

Lying design is available

Tank for range of application up to -50°C available on request





# DK-Cold water buffer tank Type 1000 to 5000, Connection in flange version

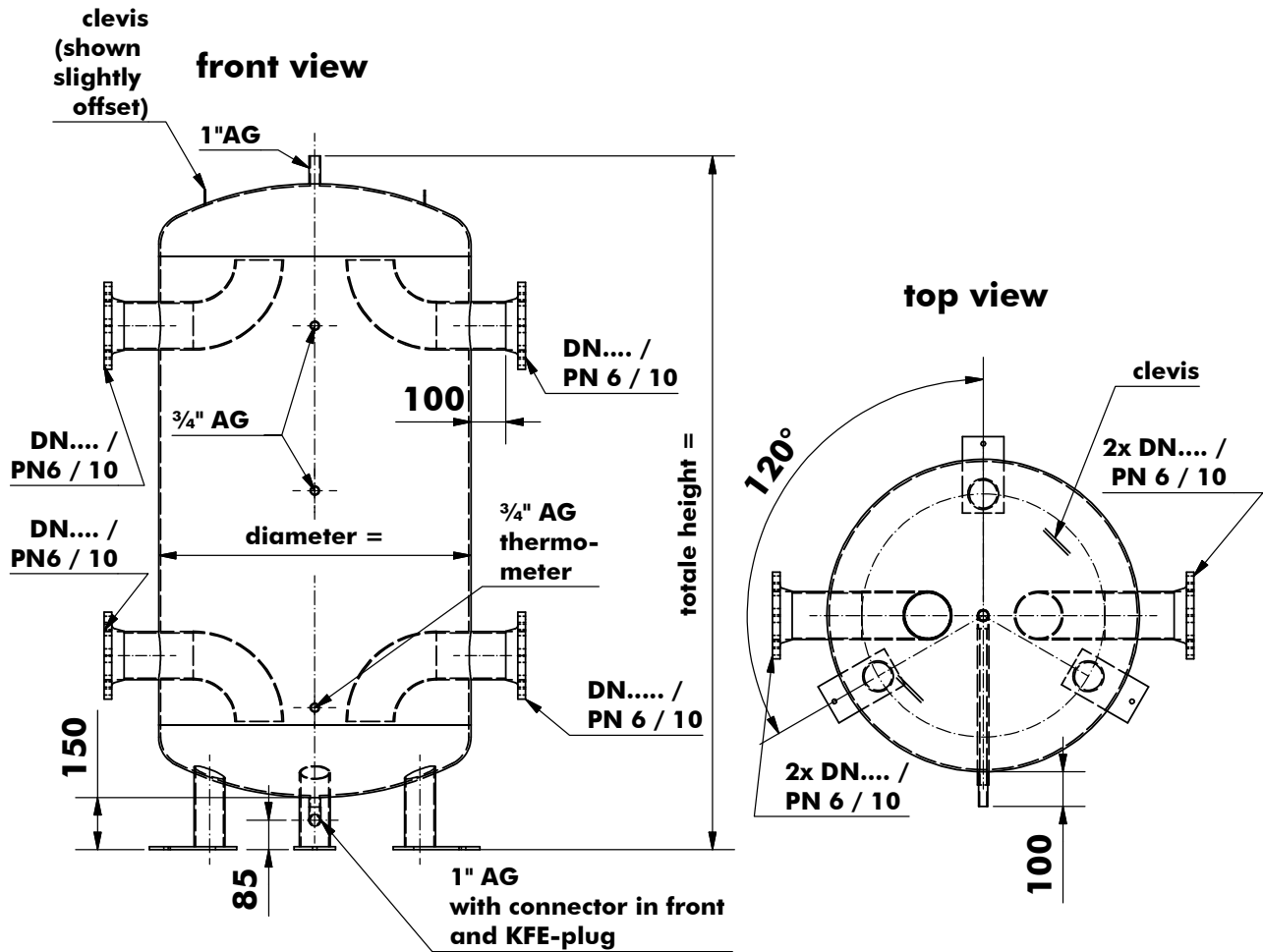

An insulation for steam diffusion containers cannot be delivered because the opportunity exists that the insulation can be damaged during the transport. Our proposal is to install the insulation by the customer after the setting up and completion of the connection.



Cooling. Heating.  
Innovation.

## DK-Cold water buffer tank as hydraulic switch gear

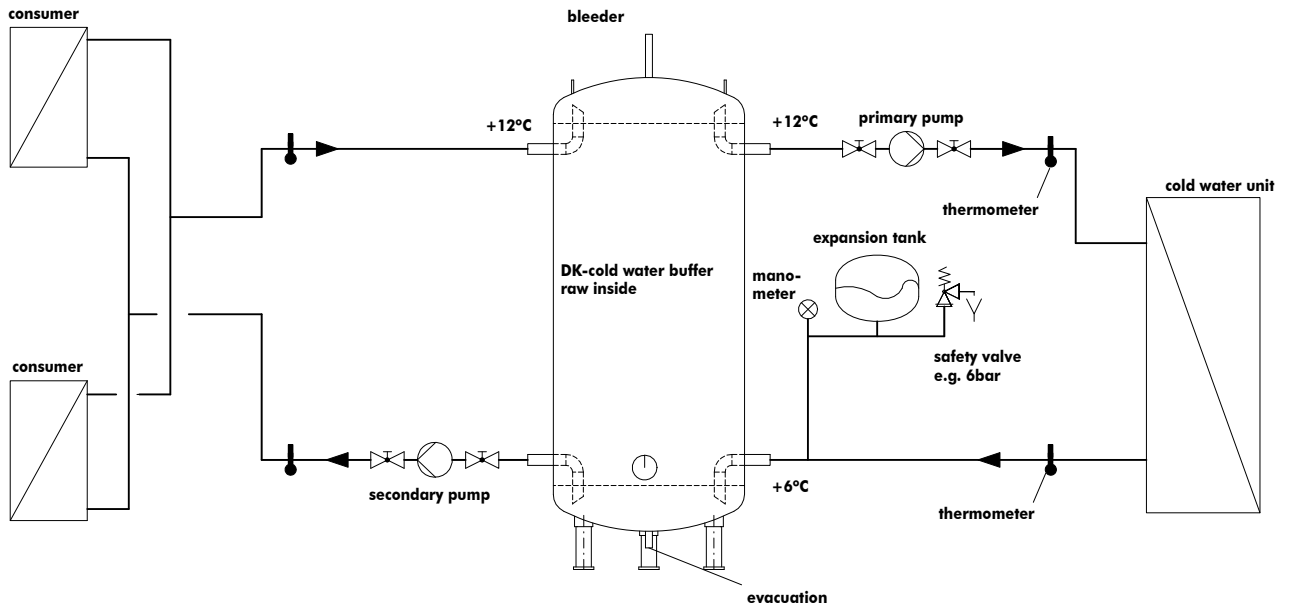



Cooling. Heating.  
Innovation.

## DK-Water Chiller for drinking water with circulation pump

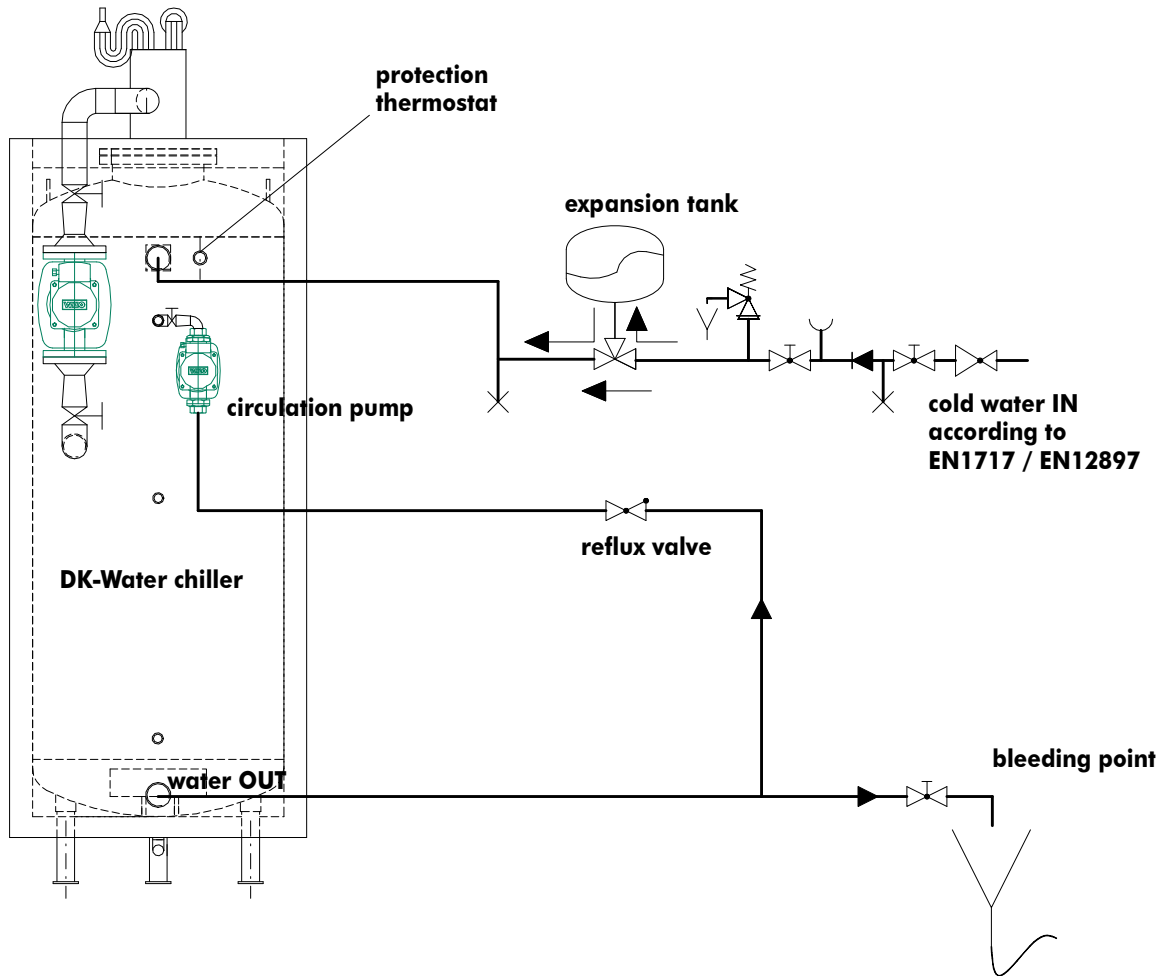





Cooling. Heating.  
Innovation.

## DK-Water Chiller with additional buffer

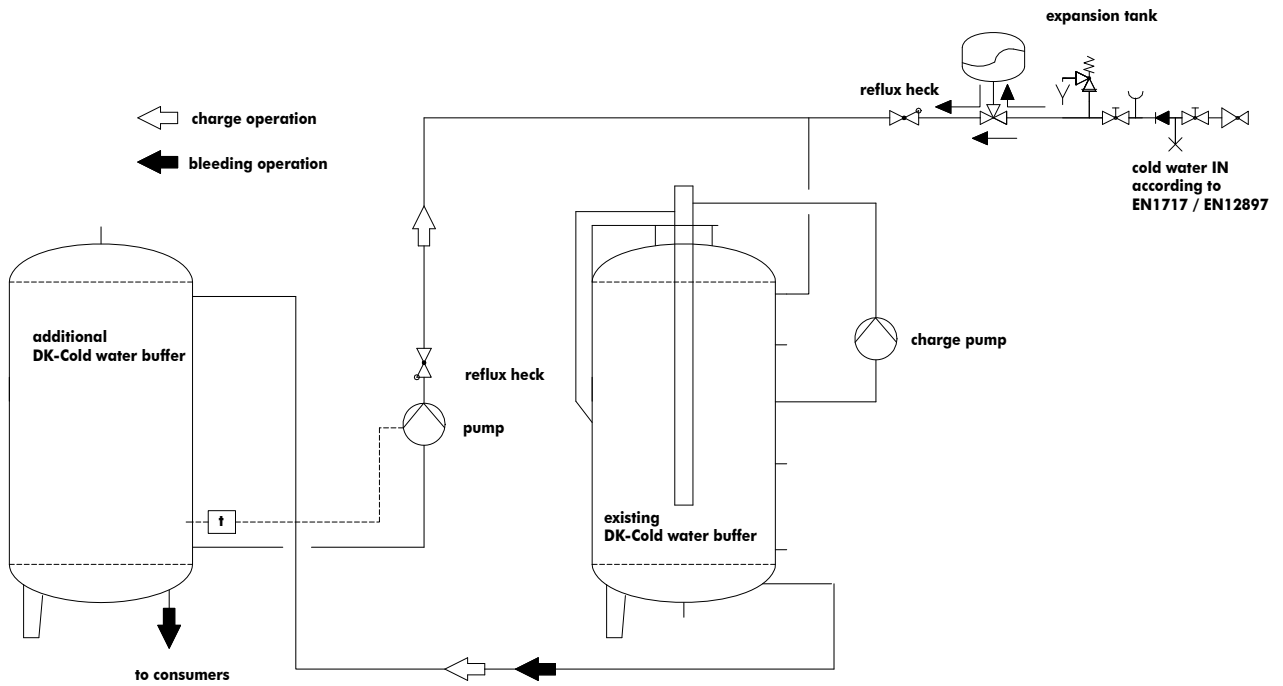



Cooling. Heating.  
Innovation.

## DK-Water Chiller / Stainless steel open system with level control

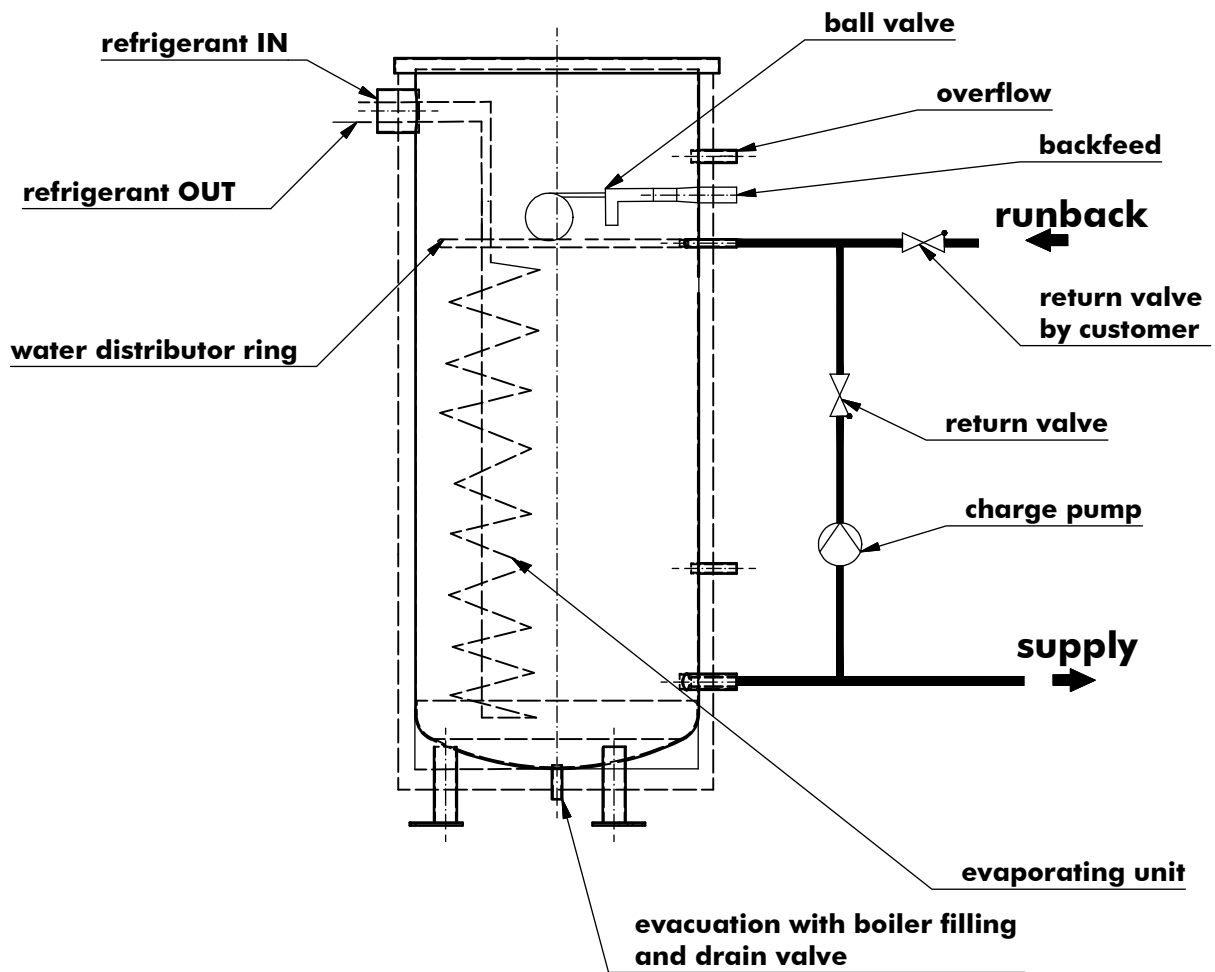









## Spare parts

Illustration	Description	Order no.
	<b>Cover for inspection hole and seal</b> 110 mm round 120 mm round <i>if enamel on flat face is poss. defective a full-face seal can be supplied incl. of new screws 8x25</i>	S31906 & S31907 S31908 & S31909
	<b>Cover for inspection hole with sleeve 12 mm and seal</b> 110 mm round 120 mm round (if magnesium anode available)	S31906 & S31907 S31908 & S31909
	<b>Cover for inspection hole and seal</b> 100/150 mm <b>Cover for inspection hole and seal</b> 80/120 mm for reservoir with magnesium anode with 12 mm sleeve	S31902 & S31900 S31903 & S31901
	<b>Flange cover and seal</b> DN 200 for heat recovery storage with <b>side flange</b> Hole circle: 245/12x16 mm	S31650 & S31600
	<b>Flange gasket</b> DN 200 For heat recovery storage with <b>bottom flange</b> Hole circle: 245/12x14 mm	S31602
	<b>Flange gasket</b> DN 200 for chilled water reservoir Hole circle: 245/12x16 mm	S31601



## Spare parts

Illustration	Description	Order no.
	<p><b>Manhole gasket DN 500</b> 610 x 500 x 3 / hole circle 565/32x18 mm</p> <p><i>for older product lines DN 450 (570 x 450 x 3 / hole circle 520/28 x 23 mm) gaskets can also be supplied</i></p> <p><b>- dimensions must be measured on site!</b></p>	<p>S31700</p> <p>S31701</p>
	<p><b>CORREX® External Current Anode</b> incl. plug-in potentiostat for heat recovery vessels for chilled water vessels</p> <p><b>CORREX® External Current Anode</b> incl. 2 probe elements incl. dual cable for heat recovery systems</p>	<p>S30000</p> <p>S33000</p> <p>S31000</p>
	<p><b>Magnesium Anodes</b> with external thread for vessels with bottom flange for vessels 120/1 for vessels 200/1 for vessels 300/1 and 500/1</p>	<p>S31100</p> <p>S31200</p> <p>S31300</p>
	<p><b>Magnesium Anodes</b> with M 12 setscrew for vessels with side flange for vessels 300/4 (<b>one anode</b>) for vessels 500/4 (<b>one anode</b>) for vessels 750/5 (<b>two anodes</b>) for vessels 1000/5 (<b>two anodes</b>)</p>	<p>S31400</p> <p>S31500</p> <p>S31400 &amp; S31200</p> <p>S31500 &amp; S31300</p>
	<p><b>Thermometer 0-120°C</b> for heat recovery vessels</p>	<p>S33500</p>
	<p><b>Angled Thermometer -30/+50°C</b> for chilled water vessel</p>	<p>S33600</p>



## Spare parts

Illustration	Description	Order no.
	<b>Boiler Thermostat</b> Switching range +25° to +90°C	S30001
	<b>Electrical heater for Enamelled Vessels</b> incl. fitted thermostat Model kW 2.0 Model kW 3.0 Model kW 4.5 Model kW 6.0 <b>Thermostat</b> loose	S30004 S30005 S30006 S30007 S33004
	<b>Overheating-prevention-thermostat</b> required when fitting electrical heating	S30008
	<b>Electrical heater for Raw Vessels</b> incl. thermostat and safety limiter Model kW 2.0 Model kW 3.0 Model kW 4.5 Model kW 6.0 Model kW 9.0	S37035 S37046 S37037 S37038 S37039
	<b>Ranco Anti-freezing Thermostat</b> (2.0) for chilled water vessel	S30221
	<b>3-Way Valve</b> 3-way mixing valve 3/4" 3-way mixing valve 1" 3-way mixing valve 1 1/2" Temperature probe for 3-way valve	S55803 S55805 S55804 S60084



## Cathodic Protection

It is technically not feasible to enamel a vessel without any flaws in the coating. Such flaws in the enamel coating are protected cathodically with the help of a **CORREX® External Current Anode** or with a **magnesium sacrificial anode**.

If a specific protection current is applied to the flaw (i.e. the unprotected steel), corrosion is excluded. The different valence of the electrochemical series of metals is used, which builds up the necessary protection current. Metal fittings, such as heat exchangers, electrical heating, probes of thermometers and thermostats impair this function.

The consequence:

The largest voltage potential is no longer between the magnesium anode and the small steel surface to be protected, but between the magnesium anode and the metal fittings. Quite frequently, the surfaces of these fittings are much larger than the flaws in the enamel so that there is a large current flow between the anode and the installed fittings, leaving the bare steel without protection. Magnesium anodes tend to be consumed much more quickly in such a case and when, following a relatively short period of time, no magnesium is left; the unprotected steel in the flawed enamel becomes the anode and sacrifices itself to the higher-valued metallic fitting. The consequence is what is called crevice corrosion, a genuine galvanic process. Only those who are aware of these correlations can take countermeasures. Galvanic currents are only linear. The heat exchangers of the DK-Heat Recovery System are fitted into plastic covers (stack effect) and the connection ends are covered inside the vessel with silicone sleeves. The heat exchangers are thus galvanically "in the shade" and are not effective. Heater battery fitted to the top, and even electrical heating fittings are installed into the vessel without producing an electrically conductive connection.

As a rule it should be attempted to avoid flaws in the enamel as best as possible. For this, DK equips all connecting nipples with an external thread so that the enamel can be applied to the very front edge. Only for the magnesium anode and electrical heater fittings are sleeves of 1, 1/4" resp. 1 1/2" welded in. These, however, are "turned out" sleeves with only 1 cm-long threads. This thread length is completely covered by the fittings. Such sleeves cannot be conventionally purchased and must be produced in low volume productions. All of this is very elaborate and dictates a relatively high price, but forms the basic requirements for a unit that functions perfectly for years.

**Manufacturers producing large volumes of enamelled vessels tend to waive these elaborate steps and are thus much cheaper. Their vessels, however, cannot be used for our purposes.**

The **CORREX® External Current Anode** guarantees a reliable and lasting protection of the vessel. For this reason, the anode need not undergo maintenance as the magnesium sacrificial anodes have to. The CORREX® External Current Anode secures a long and safe life. Moreover, the CORREX® External Current Anode provides precision control of the protection current, an optimal function control, no overprotection (electrolytic gas risk) and no formation of anode slime.

A 230 V-outlet with continuous voltage should be installed in the immediate vicinity to the vessel of the DK-Heat Recovery System since the supplied connecting cable of the CORREX® External Current Anode must not be severed and extended. Otherwise, there is the risk that the polarity is reversed: instead of protection against corrosion, an increase in corrosion is the result.



Cooling. Heating.  
Innovation.

**DK-Kälteanlagen offers two different types:**

CORREX® External Current Anode 230 V / 4W

&

CORREX® External Current Anode 230 V/4 W with 2 probe elements

(for reservoirs 1000 l and reservoirs 750 l as of 8 m<sup>2</sup> Heat Exchanger surface necessary)

**Magnesium sacrificial anodes** have to be inspected after 2 years for the first time. If consumed by over 50%, the anode must be replaced by a new anode.

Order number	For storage type	Diameter (mm)	Length (mm)	Connection	Fitted
50/1	31100	22	400	3/4"	from front
120/1	31100	22	400	3/4"	from front
200/1	31200	33	400	1 1/4"	from front
300/1	31300	33	600	1 1/4"	from front
500/1	31300	33	600	1 1/4"	from front
300/4	31400	33	550	M 12	from below
500/4	31500	33	735	M 12	from below
750/5	31400	33	550	M 12	from below
	31200	33	400	1 1/4"	from front
1000/5	31500	33	735	M12	from below
	31300	33	600	1 1/4"	from front



## Dealing with legionella

When talking heat recovery, the subject of legionella frequently arises and only few know what this is about. Legionella are bacteria which in principle are contained in any potable water. However, the excessive growth of legionella must be prevented.

The use of copper for heat exchangers in DK-Heat Recovery systems reduces the growth of legionella since copper inhibits the growth of the bacteria. How to perform thermal water installations with regard to legionella is regulated by the DVGW work sheet 511.

In principle, a differentiation is made between so-called small and large installations. Small installations are vessels with a capacity of up to 400 l and do not require any measures. All vessels beyond that capacity are considered large installations whose total capacity of water must be heated at least once a day to +60°C.

### Brief overview – operation of installations

DVGW = German Technical and Scientific Association for Gas and Water

Potable water heater	Content (l)	Operation/Temperature
Small installations	≤ 400	Operating temperature ≤ 60 °C is possible
Large installations	> 400	Temperature of 60°C*) at warm water outflow of potable water heater must be maintained. The full water capacity from pre-heating stages must be heated at least once a day to +60°C

\*)taking into account the switching differential of the regulator, a temperature of 55°C must be reached.

For this, DK offers a so-called **Legionella-kill-unit**. A connecting line with a pump and return valve is installed between the warm water outflow and the cold water inflow. The upper part of the vessel can hold an electrical heater or a PWW heater battery. A thermostat to the lower part of the vessel senses if once a day the water temperature reaches +60°C. No further measures are necessary after that. Should +60°C not have been reached, it is best to activate the electrical heater or the PWW heater battery including the pump of the bypass line at a time when warm water is not used, e.g. at 2 a.m., to ensure that the entire contents of the vessel is post-heated to +60°C.

If the vessel precedes another thermal water installation as a pre-heating vessel, then the sanitary company should install a switch to the after-heating vessel to heat the entire warm water system to +60°C. No further measures need to be taken in this case for the DK-Heat Recovery System.

### Legionella-kill-unit

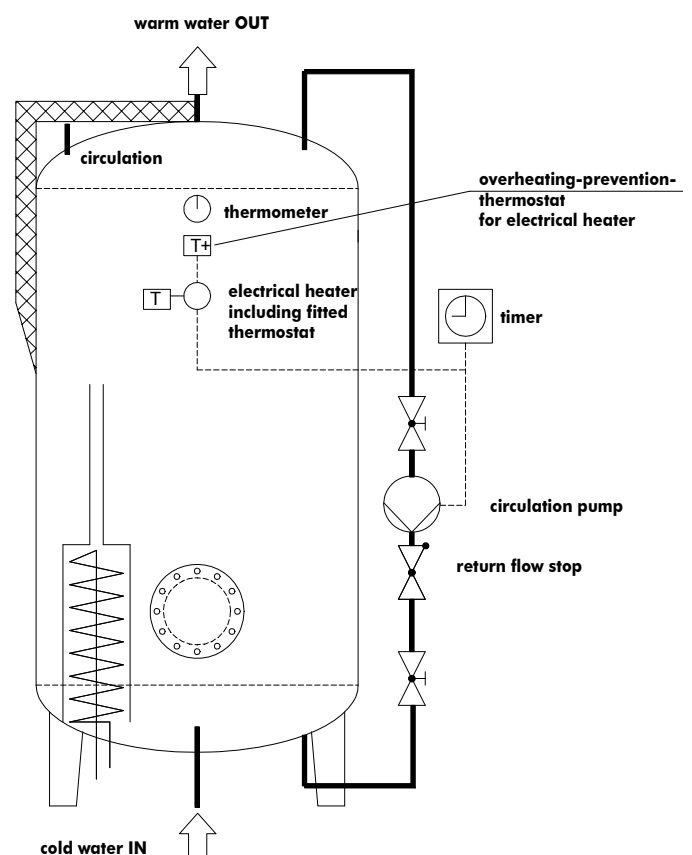





# TENDER TEXT PAGE 1

Standard program HR

Pos.	Piece	Price
	<p>.....</p> <p><b>Unit DK Heat Recovery comprising:</b></p> <p>Drinking water storage model</p> <p>_____ mm diameter, no insulation          _____ mm diameter, with insulation          _____ mm overall height of construction          _____ l nominal capacity</p> <p>Walls 3 – 4.5 mm made of USt 37-2.          An oval blank plug 100/150 mm in the lower bottom, also the required nipple connections for installation of heat exchangers.          In the lower part of the vessel's jacket a single ended flanged nipple 200/280 mm diameter in accordance with DIN 4805 at inspection opening.</p> <p>CW and WW each 1 1/4", thermometer connection 3/4" incl. thermometer, circulation and thermometer connection each 3/4" as well as 1 1/2" connection for electrical heating at customer.</p> <p>Vessel built and determined in accordance with DIN 44899 sheet 5 and worksheet W 511. Vessel suitable for 6 bar operating pressure at +95°C operating temperature, water pressure tested for 8 bar, certified.</p> <p>Corrosion protection:          outside enamel mist, inside double enamel layer with magnesium reactive anode</p> <p>alternatively: _____ units CORREX® External Current Anode</p> <p>Insulation with glass fibre reinforced polyester hard case with PU foam. Insulation supplied with 2 shells attached to each side of the vessel with 2 foamed-in quick acting closures.</p>	<p>.....</p>



## TENDER TEXT PAGE 2

### Standard program HR

Pos.	Piece	Price
.....	Special counterflow heat exchanger in double-walled safety design of a quality fit for food consumption for freon. Exchanger made of copper finned helical and electrotinned tube. Counterflow tubing made of odourless and tasteless heat resistant plastic. Exchanger built in vessel with brass screwing in vessel. Counterflow water volume adjusted to the respective condensation heat through throttle.  <b>Type:</b> 16/10 mm 0.4m <sup>2</sup> pipe connection 10 mm (soldered) <b>Capacity:</b> max. 1500 Watt ( $\Delta t_m$ 25 K)	.....
.....	Special counterflow heat exchanger as above, but with  <b>Type:</b> 16/10 mm 0.8m <sup>2</sup> pipe connection 10 mm (soldered) <b>Capacity:</b> max. 3000 Watt ( $\Delta t_m$ 25 K)	.....
.....	Special counterflow heat exchanger as above, but with  <b>Model:</b> 18/12mm 1.2m <sup>2</sup> pipe connection 12 mm (soldered) <b>Capacity:</b> max. 6000 Watt ( $\Delta t_m$ 25 K)	.....
.....	Special counterflow heat exchanger as above, but with  <b>Model:</b> 22/16 mm 1.0m <sup>2</sup> pipe connection 16 mm (soldered) <b>Capacity:</b> max. 6000 Watt ( $\Delta t_m$ 25 K)	.....
.....	Special counterflow heat exchanger as above, but with  <b>Model:</b> 22/16 mm 2.0m <sup>2</sup> pipe connection 16 mm (soldered) <b>Capacity:</b> max. 12000 Watt ( $\Delta t_m$ 25 K)	.....
.....	Special counterflow heat exchanger as above, but with  <b>Model:</b> 22/16 mm 3.0m <sup>2</sup> pipe connection 16 mm (soldered) <b>Capacity:</b> max. 18000 Watt ( $\Delta t_m$ 25 K)	.....



## TENDER TEXT PAGE 3

Standard program HR

Pos.	Piece		Price
	.....	Special counterflow heat exchanger as above, but with  <b>Model:</b> 28/20 mm 1.5 m <sup>2</sup> pipe connection 22 mm (soldered) <b>Capacity:</b> max. 9000 Watt ( $\Delta t_m$ 25 K)	.....
	.....	Special counterflow heat exchanger as above, but with  <b>Model:</b> 28/20 mm 3.0 m <sup>2</sup> pipe connection 22 mm (soldered) <b>Capacity:</b> max. 18000 Watt ( $\Delta t_m$ 25 K)	.....
	.....	Heat exchanger for heating water exchanger made of helical and electroplated copper. Electroplated exchanger built in ineffectively in upper part of vessel case.  <b>Surface:</b> 2.5 m <sup>2</sup> <b>Connecting dimension:</b> 22 mm (screwing)	.....



## TENDER TEXT Page 1

### Service Water Buffer Tank enamelled with connections for tubular desuperheater

Pos.	Piece	Price
.....	<p>Service water buffer storage</p> <p>_____ mm diameter, no insulation            _____ mm diameter, with insulation            _____ mm total height            _____ l capacity</p> <p>Walls made of 3-4.5 mm ST 37-2, can be enamel-coated oval blank plug 100/150 mm in bottom, CW and WW each 1 1/4", thermometer connection 3/4" incl. thermometer, thermostat and circulation connection each 3/4", electric heating connection 1 1/2", as well as supply lines and mountings to install an external tubular desuperheater/ tubular condenser. Vessel built and determined in accordance with DIN 44899, sheet 5 and worksheet W 511, suitable for 6 bar operating pressure at +95°C operating temperature, water pressure tested for 8 bar, certified.</p> <p>Corrosion protection            outside enamel mist,            inside double enamel layer            with magnesium reactive anode</p> <p>Insulation made of glass fibre reinforced polyester hard case with PU foam. Insulation supplied with 2 shells attached to each side of the vessel with 2 foamed-in quick acting closures.</p>	.....
.....	<p>CORREX® External Current Anode            -maintenance free-            (alternatively to built-in serial magnesium reactive anode)</p>	.....
.....	<p>electrical heater _____ kW            incl. built-in thermostat</p>	.....
.....	<p>Overheating protection thermostat            (set to +95°C when supplied)</p>	.....
.....	<p>Boiler thermostat (switching range +25/+95°C)            to switch a magnetic valve in hot gas bypass line</p>	.....



## TENDER TEXT Page 2

### Service Water Buffer Tank enamelled with connections for tubular desuperheater

Pos.	Piece	Price
	<p>..... Tubular desuperheater/tubular condenser double-walled safety design comprising: Copper tube _____ mm with _____ inserted double-walled Copper finned tube 16/10 mm Length per finned tube: _____ m Total length of construction: _____ m Connection refrigerant carrying side max.: _____ mm Connection water-carrying side max.: _____ mm Surface refrigerant carrying side: _____ m<sup>2</sup> Water circulation volume: _____ m<sup>3</sup>/h <math>\Delta p</math> water: _____ bar incl. mounting incl. insulation</p> <p>Type</p> <p>Tubular desuperheater/condenser as tertiary heat exchanger built according to design D as per EN 1717, part 4, par. 5.2</p>	.....
	<p>..... temp.-depend. controlled water valve Type SW charge pump Type incl. screws, stop valve and tubular desuperheater/condenser mounted vertically to vessel.</p> <p>If galvanised water lines are subsequently attached to the tubular desuperheater / condenser it is necessary to nickel-plate the heat exchanger on the water carrying side.</p> <p>The surcharge for this is 25 %.</p>	.....



## TENDER TEXT

for customised productions enamelled or REXIT-coated

Pos.	Piece		Price
	.....	<p><b>DK Heat Recovery comprising:</b></p> <p>Service water standing reservoir            _____ mm diameter, <b>no</b> insulation            _____ mm diameter, <b>with</b> insulation            _____ mm total height</p> <p>Walls made of ST-37-2,            discharge opening in the bottom of the container as well as required            nipple connection to install heat exchangers. To the lower part of the            vessel's jacket a manhole 450 or 500 mm diameter as per DIN            4805 as inspection or assembly flange. Cold water inlet and water            outlet each 2", thermometer, thermostat and circulation connection            each 3/4", electrical heating connection 2".            Vessel built and determined as per DIN 44899, sheet 5 and            worksheet W 511.            Vessel suitable for 6 bar operating pressure at +95°C operating            temperature, for 1.3-fold of permissible operating pressure water            pressure tested, certified.</p> <p><b>Corrosion protection            (for reservoirs of up to 1200 mm diameter)</b>            primed outside            inside double-layer enamel, incl. CORREX® External Current            Anode/2 sensors</p> <p><b>Corrosion protection            (for reservoirs of up to 1200 mm diameter)</b>            primed outside            inside 5-fold plastic coating (REXIT K 59 T-M),            design tested by TÜV Essen,            inspection no. 710506/01 2.3. 1-124/97</p> <p>Insulation made of 80 mm strong closed pore foam comprising coat            and end plate, cover made of PVC tissue case with strapped or            Velcro closure</p>	.....



# TENDER TEXT Page 1

## Water Chiller with built-in KS-Evaporator

Pos.	Piece	Price
	<p>..... <b>Cold water buffer storage for closed water system (no oxygen supply)</b></p> <p>inside raw, outside thick primer</p> <p>_____ mm diameter with insulation            _____ mm total height            _____ l capacity</p> <p>with connections for cold water inlet and outlet 1 1/4" or 2" pump connection, 3 connections 3/4" distributed to vessel's jacket inc. machine thermometer -30/+50°C, switch length 160 mm installed in bottom connection of 3 connections <b>Drainage 3/4" with KFE tap 3/4"</b>, inc. safety valve 1"-2.5 bar, <b>Thermometer connection 1"</b>, inc. flange in upper vessel bottom to hold shell-&amp;-tube evaporator.</p> <p>Vessel built and determined in accordance with DIN 44899, sheet 5 and worksheet W 511, suitable for 6 bar operating pressure at +95°C Operating temperature, water pressure tested for 8 bar, certified (application range up to -20°C)</p> <p>incl. insulation with pressure foamed design with glass fibre reinforced plastic hard case sealed against diffusion of vapour. Insulation at point of impact and connections bonded against diffusion of vapour.</p> <p><b>KS-shell-&amp;-tube evaporator</b></p> <p>..... comprising:</p> <p>Copper shell tube _____ mm diameter with _____ inserted single-walled Cu-KS-Evaporator tubes 15 mm Length per evaporator tube: _____ m Total length: _____ m incl. _____-fold deflection resulting in an evaporator length of _____ x _____ = _____ m, incl. _____-fold injection with distributor</p> <p>..... Capillary tube 5 or 6 mm, Fluid connection: _____ mm incl. suction-side conversion to _____ mm Connection water in shell: _____ inch Surface: _____ m<sup>2</sup></p>	<p>.....</p> <p>.....</p> <p>.....</p>



## TENDER TEXT Page 2

### Water Chillers with built-in KS-Evaporator

Pos.	Piece		Price
		Type	
	.....	<b>Cold water charge pump</b> Type Supply voltage: 230/400 V Connection dimension: for forced overflow of evaporator incl. stop valve and insulated tubes mounted to outside of vessel incl. manual and fast-action bleeder at highest point of tube	.....
	.....	<b>Ranco switch thermostat 016-H6989</b>	.....
	.....	<b>Ranco frost protection thermostat (2,0) D9040</b> K22-L2564 Length of Capillary tube 2.0m with probe sleeve installed in evaporator package	.....
		PS Enamelled vessel of double-walled safety evaporators can be supplied for use in the food sector.	





## TENDER TEXT

### Cold Water Buffer Standard

Pos.	Piece	Price
	<p>..... <b>Cold water buffer storage for closed water system (no oxygen supply)</b></p> <p>inside raw, outside primed</p> <p>_____ mm diameter, with insulation            _____ mm total height            _____ l capacity</p> <p>Cold water inlet and outlet 1 1/4" (2 connections primary, 2 connections secondary) connections in vessel with 90° arc in bumped boiler end so that there is an effective loading and unloading of storage.            3 connections 3/4" distributed to vessel case, connection 3/4" to drain lower bottom, connection 3/4" to bleed upper bottom, incl. machine thermometer -30/+50°C, shaft length 160 mm, built into lower one of 3 connections</p> <p>Vessel built and determined in accordance with DIN 44899, sheet 5 and worksheet W 511, suitable for 6 bar operating pressure at +95°C operating temperature, water pressure tested for 8 bar, certified</p> <p>incl. insulation with pressure foam design with glass fibre reinforced hard case sealed against diffusion of vapour.            Insulation at impact point and connections bonded against diffusion of vapour.</p>	<p>.....</p>
	<p>..... Surcharge for larger water connections            flange design DN ____ / ____ PN (inlet / outlet)</p>	<p>.....</p>
	<p>..... Surcharge for additional water connections            flange design DN ____ / ____ PN (inlet / outlet)</p>	<p>.....</p>



## TENDER TEXT

### Cold Water Buffer Customised Design

Pos.	Piece	Price
	<p>..... <b>Cold water buffer storage customised design -raw- (no insulation)</b></p> <p>Cold water buffer storage for closed water systems (no oxygen supply) inside raw, outside thick primer</p> <p>_____ mm diameter            _____ mm total height            _____ l capacity</p> <p>Cold water inlet and outlet each 2", thermometer connection 3/4" incl. thermometer, 3 connections 3/4" (e.g. for thermostats) in vessel case, connection 3/4" for drainage in lower bottom with KFE tap, connection 3/4" for bleeding in upper bottom.</p> <p>Vessel built and determined in accordance with DIN 44899, sheet 5 and worksheet W 511, suitable for 6 bar operating pressure at +95°C operating temperature, water pressure tested for 8 bar, certified</p> <p>An insulation which is sealed against diffusion of vapour, such as made of Armaflex plates, is not available as the vapour-sealed outer skin could be damaged during transport and during installation. We therefore suggest installing such insulation after setting up and completing the connections at the customer.</p> <p>..... Surcharge for larger water connections of flange design DN _____ (inlet and outlet)</p> <p>..... Surcharge for larger water connections of flange design DN _____ (inlet and outlet)</p>	<p>.....</p> <p>.....</p> <p>.....</p>