



BRINGING  
**SPACES UNDER CONTROL.**



ALWAYS IN  
CONTROL  
**OF YOUR  
PRECOOLING  
AND RIPENING**



Quality equipment is a precondition for optimum results in fruit cooling and ripening for a wide range of fruits, including bananas. Perfectly insulated fruit ripening rooms ensure satisfactory performance. BG Door has developed a superior range of gas-tight doors and ripening room equipment using high-grade materials. A thorough assessment of your requirements enables us to prepare an exclusive tailor-made design for your facility. Making sure you're always in control of your ripening.

Thanks to our broad experience and close cooperation with major specialists in the field of banana ripening we can offer you several disciplines. Knowing what you want to reach is important during the whole process from information to after sales. Our tailor-made advice is the starting point for successful projects.

**Additional services**

- ▶ Consultancy before, during and after the project.
- ▶ Supply and assembly of special designed gastight doors.
- ▶ Quick service and maintenance, with or without local back-up.

# GASTIGHT SECTIONAL DOORS



**S**uited for storage rooms, fruit ripening chambers (including tropical fruit and in particular bananas). The door consists of sections. Tracks are self-supporting and (depending on the rail system) the door leaf is guided horizontally, vertically or following the roof pitch. The spring systems are pre-assembled with powder-coated springs. Cable break bottom fixtures are standard supply. The sections are structured according

to the sandwich principle. The insulation core consists of CFC-free solid polyurethane foam. The interior and exterior sheet, consists of 0.5 mm thick galvanized coated steel sheet. The sophisticated panel connections with special sealing, in combination with the 3-flap gaskets around the door perimeter, ensure optimum gas tightness. Supplied standard with kick-out window that doubles as an emergency exit.



**RUNNING INSIDE,  
OUTSIDE OR OVER**  
TOP OF ROOMS



**UP-TO-DATE  
SAFETY DEVICES**  
INTEGRATED



**HIGHEST GAS TIGHTNESS**  
CERTIFICATION  
CLASS 6+ TÜV NORD

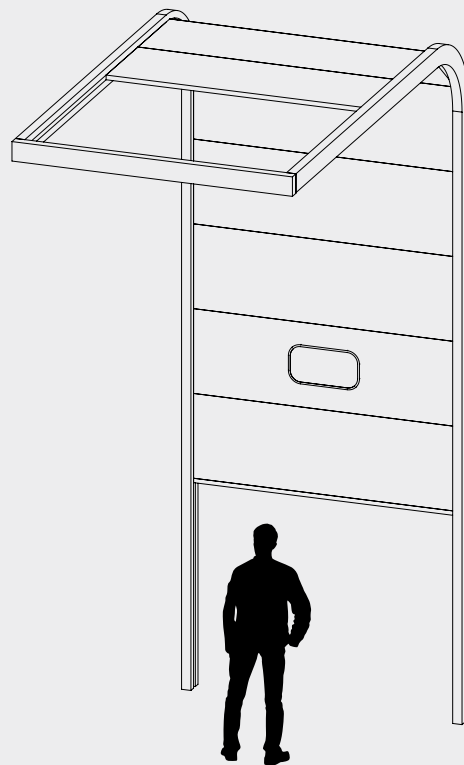

## CHARACTERISTICS

- ▶ 40 or 80 mm thickness embossed with lines on external side, flat non-embossed on inside.
- ▶ Variety of standard colours available on external side.
- ▶ Grey White RAL 9002 on internal side.
- ▶ Any other colour by spray coating available.
- ▶ Electric operation: motor directly on shaft, fitted with all safety devices like bottom safety edge and slack cable protection.
- ▶ Door control can be connected to Ripening Room control systems.

 Gas Tight

# GASTIGHT PANEL DOORS



**S**uited for storage rooms, fruit ripening chambers (including tropical fruit and in particular bananas). The door consists of a single door leaf with sections that have been pre-fitted into an anodised, aluminium frame. The tracks are self-supporting and the door leaf is guided vertically. The spring systems are pre-assembled with powder-coated springs. Cable break bottom fixtures are standard supply. The sections are structured according to the sandwich principle. The

insulation core consists of CFC-free solid polyurethane foam. The interior and exterior sheet consists of 0.5 mm thick galvanized coated steel sheet. The sophisticated panel connections with special sealing, in combination with the 3-flap gaskets around the door perimeter, ensure optimum gas tightness. Supplied standard with kick-out window that doubles as an emergency exit.



**PRE-ASSEMBLED**  
FOR EASY  
INSTALLATION



UP-TO-DATE  
**SAFETY DEVICES**  
INTEGRATED



**HIGHEST GAS TIGHTNESS**  
CERTIFICATION  
CLASS 6+ TÜV NORD

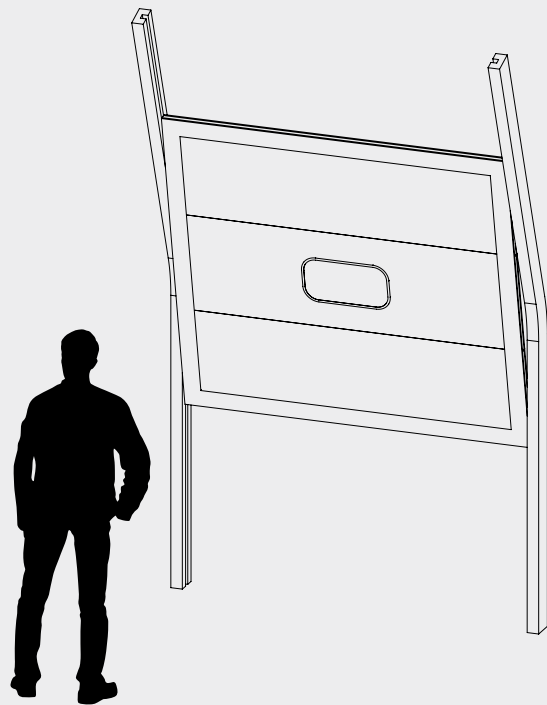

## CHARACTERISTICS

- ▶ Available in 40/80/100 mm thickness embossed with lines on external side, flat non-embossed on inside.
- ▶ GPD 40 in various standard colours, GPD 80/100 standard in RAL 9010 Clear White and RAL 9002 Grey White.
- ▶ Can be spray coated in selected RAL or NCS colours.
- ▶ Electric operation: motor directly on shaft, fitted with all safety devices like bottom safety edge and slack cable protection.
- ▶ Door control can be connected to Ripening Room control systems.

 Gas Tight

# GASTIGHT FLEX DOORS



**S**uited for storage rooms, fruit ripening chambers (including tropical fruit and in particular bananas). Especially suitable where free clearance is limited. The door is rolled up around a steel cylinder above the clear span; side-guided by means of aluminium guides with pneumatic cylinder, which is activated after closure and seals the door hermetically. The track cylinders must

be connected to 8 bar operational air pressure. The door leaf consists of 1 mm PES fabric with 4 mm polyurethane insulation on the inside. The flexible bottom gasket is weighted and therefore guarantees a perfect sealing. The side guides are executed with radar safety strips to a height of 2.5 m, providing optimum safety to persons and objects when the door closes.





PREMIUM  
**SEGMENT**



SUITABLE FOR  
**LIMITED  
ISLE SPACE**



OPTIMUM GAS  
TIGHTNESS BY  
**SPECIAL TRACK SYSTEM**

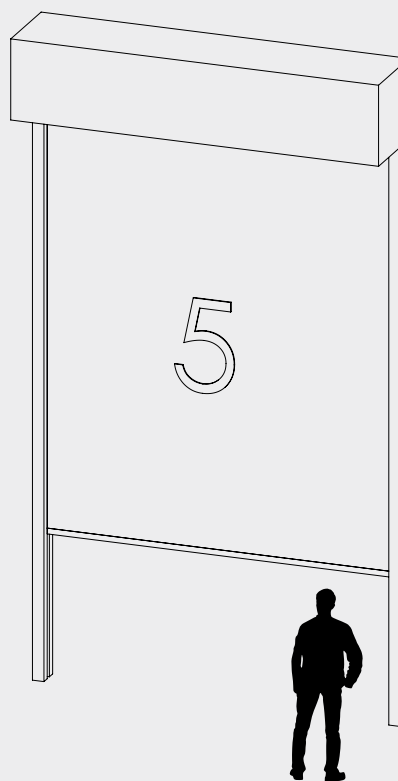

## CHARACTERISTICS

- ▶ Covers, side guides and top cylinder in any required colour; door leaf in standard White colour.
- ▶ Temperature range -30°C to +70°C.
- ▶ Door leaf with full colour logo can be connected to Ripening Room control system.

 Temperature

# ISO THERM DOORS



**S**uited for cold storage rooms, temperature-controlled areas. Extremely user-friendly and suitable for frequent use. The door consists of sections and is 80 mm thick. The insulation core consists of CFC-free solid polyurethane foam. The interior and exterior sheet, consisting of 0.5 mm thick galvanised steel sheet, have an oven-hardened, polyester coating. A partition between the interior and exterior sheet

guarantees a high insulation value; bottom and top profile are thermal bridge interrupted. The thermal bridge interrupted panels are provided with PVC capping for minimal condensation. Double executed bottom and top gaskets, to secure high insulation values.



PERFECTLY  
**SUITABLE FOR  
COOL ROOMS**



**THERMAL BRIDGE  
INTERRUPTED  
PANELS AND SEALS**



UP-TO-DATE  
**SAFETY DEVICES  
INTEGRATED**

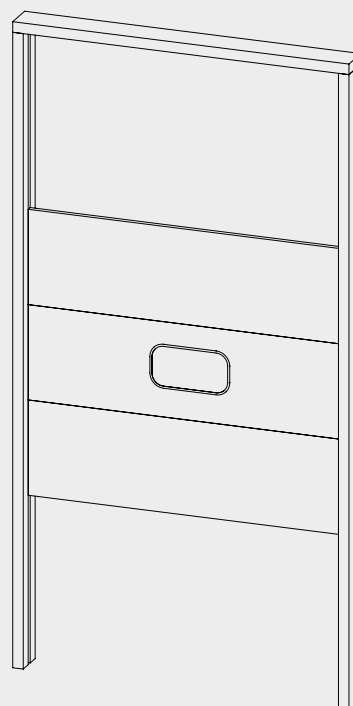

## CHARACTERISTICS

- ▶ ITD 80 - Thermo Door thickness 80 mm.  
Finish: Thermal bridged interrupted bottom and top profile, in- and outside in Grey White RAL 9002.
- ▶ ITD 80 - Door thickness 80 mm.  
Finish: inside and outside embossed surface in Grey White RAL 9002.
- ▶ Thermally interrupted assembly frame, for minimal condensation.
- ▶ Pass door with lowered threshold, 40 mm.
- ▶ Pass door suitable to escape, threshold 20 mm.

- ▶ Electric operation: Motor directly on shaft (400V/50Hz) fitted with optical sensor safety device and slack cable protection.
- ▶ Windows: milled or full glass sections in quadruple acrylic full glass sections with thermally interrupted profiles.

## INSULATION VALUE

- ▶ Door 4.000 x 4.000 mm (wxh) complete door with thermal interrupted frame 0,5 W/m<sup>2</sup>K.

 Temperature

# ISO ROLL DOORS



Insulated flexible roll door for temperature-controlled zones or areas for inside use, e.g. (fruit) storage unit. Suitable for internal partition with relatively high temperature differences. Door leaf consists of PVC. Trevira fabric 2mm outside and 0.5mm inside. In between is insulating polyether 46/120 in the thickness of the door model. The individual panels of 2,000 mm wide are interlinked in the door, so that there is no limit to the width that can be supplied. Condensation problems are limited to a minimum due to the water

vapour permeability of the materials used, while at the same time, the maximum insulation value is achieved because of the complete absence of thermal bridges. Electric operation by means of direct drive: electric motor, control unit, transmissions and limit switches. Controlled by means of 3 buttons (open - stop - close). When closing the door, the 'close' button must be pressed continuously for safety reasons (dead man's switch).



PERFECTLY  
**SUITABLE FOR  
COOL ROOMS**



**THERMAL BRIDGE**  
INTERRUPTED  
PANELS AND SEALS



UP-TO-DATE  
**SAFETY DEVICES**  
INTEGRATED

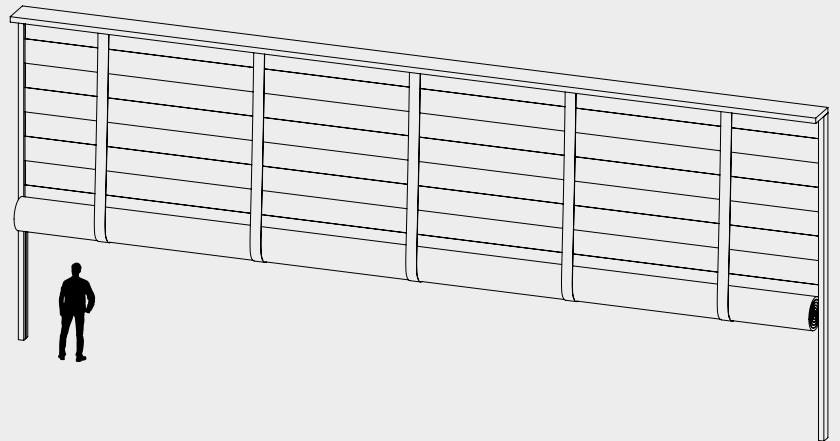

## CHARACTERISTICS

- ▶ Opening and closing speed is approx. 0.10 m/sec.
- ▶ Temperature range: - 35°C to +80°C.
- ▶ Iso roll door in 40/60/80 mm thickness.
- ▶ Thermally interrupted profiles.

✘ Separation

# SEPARATION FLEX DOORS



**C**ompartimentation for temperature-controlled units: as a partition wall in production halls to avoid dirt, dampness or draught. Suitable for large spans. Consists of single canvas with a vertical hoisting belt at every 1500 mm. The hoisting belts are rolled around a steel winding shaft, so that the canvas is pulled up like a folding curtain. The side fitting hangs freely at approx. 10 mm from the wall. Two steel receiver guides are fitted on the floor at both ends to lock the bottom tube.



CREATES  
**NON-INSULATED  
SEPARATION WALL**



**LARGE AREAS**  
SMALL TEMPERATURE  
DIFFERENCES



LIGHT-WEIGHT  
**NO DAMAGE  
BY COLLISION**

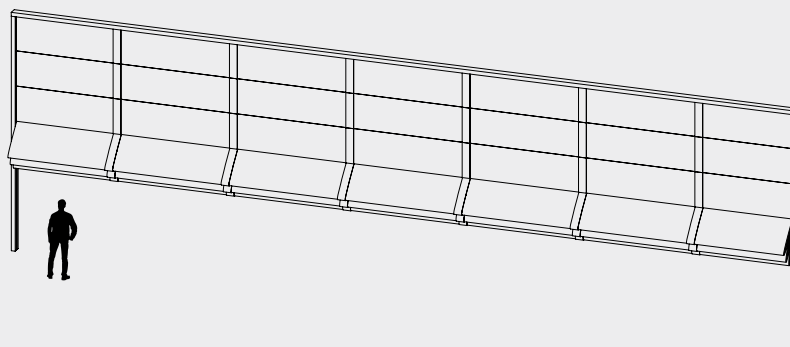

## CHARACTERISTICS

- ▶ Electric operation by means of a 220V/50Hz tube motor.
- ▶ Dimensions: up to 50 metres wide / 8 metres high.
- ▶ Several SEPA Flex Doors can be linked to provide limitless width.
- ▶ Available in 46 standard colours.

✘ Separation

# DUAL FLEX DOORS



**L**ifting folding door, particularly suitable for sealed units under pressure. For internal or external use, such as blasting cabins (high-pressure jet cabins). The door leaf consists of steel or aluminium profiles of 170 mm thickness, with PES fabric of 900 g/m<sup>2</sup> on inside and outside. The lifting mechanism consists of several polyester hoisting belts that are linked at the inside of the bottom beam. Electrically operated by 400V plug-in motor.





PERFECTLY  
SUITABLE AS  
**BLAST CABIN DOOR**



**INDUSTRIAL  
HEAVY USE**  
HOIST UP TYPE



**OPTIMUM  
SEALS**

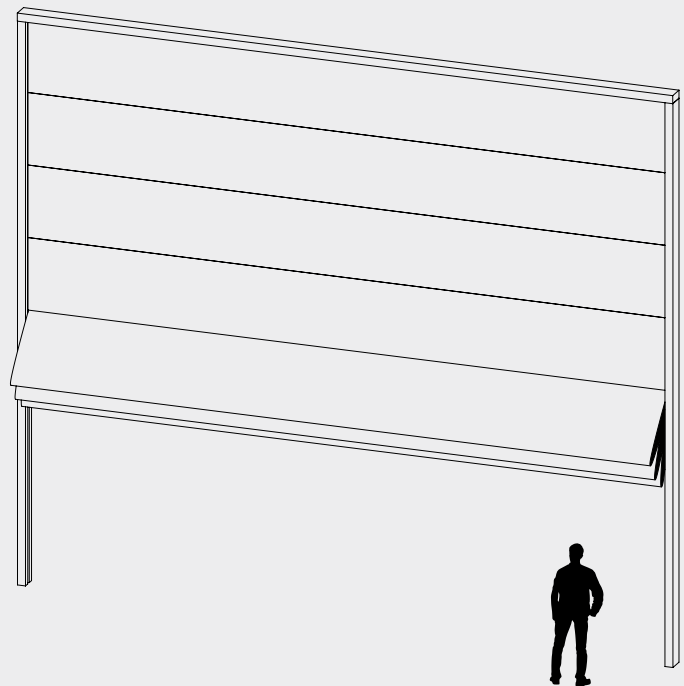

## CHARACTERISTICS

- ▶ Withstands temperatures from +70°C to -35°C.
- ▶ Pulling strength of canvas: 4000 N/5cm according to DIN 53 354.
- ▶ Tear resistance: 600 N according to DIN 53 356.
- ▶ The material is UV resistant and rot-proof.

# SECTIONAL OVERHEAD DOORS



**F**or industrial use and all types of business units: for interior as well as exterior use. The door consists of sections. The sections are structured according to the sandwich principle and are approx. 40 mm thick. The insulation core consists of CFC-free solid polyurethane foam. The interior and exterior sheet, consisting of 0.5 mm thick galvanized steel plate.

A thermal partition between the interior and exterior sheet guarantees a high insulation value. The sophisticated panel connections with sealing that remains supple, in combination with adequate sealing around the door leaf, ensure that wind and water are kept outside.



HIGH-QUALITY  
**OVERHEAD  
DOORS**



UP-TO-DATE  
**SAFETY DEVICES**  
INTEGRATED



AVAILABLE IN  
**40 / 60 / 80 MM**  
**PANEL THICKNESS**

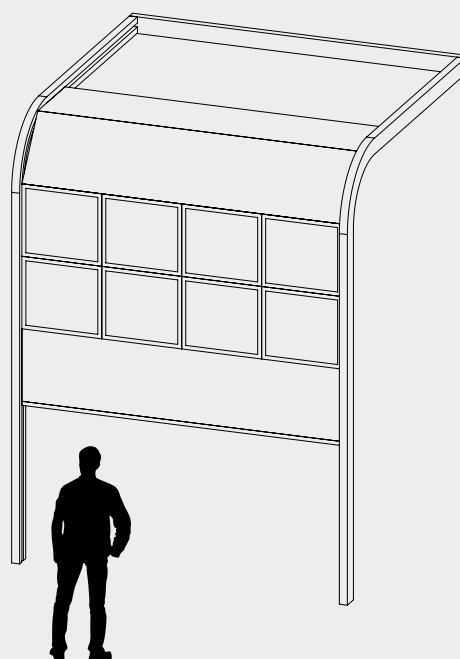

## CHARACTERISTICS

- ▶ 40 mm insulated door panels, embossed with lines.
- ▶ Additional windows milled in panels or full glass panels.
- ▶ 40 mm full glass panels with aluminium profiles.
- ▶ Optional panoramic window panels.

## OPTIONAL

- ▶ Electrical operation, photocell protection, remote control.
- ▶ Heavy-duty version for 100,000 cycles.
- ▶ Stainless steel door fittings.
- ▶ Pass door with 20 mm low threshold.
- ▶ Pass door with canopy.

# SPEED ROLL DOORS



**S**peed Roll Doors are fast moving doors for universal internal and external applications. The perfect solution for use as partition, for climate control and for improving the internal work flow. The doors are provided with self-supporting tracks with modular design. Speed roll doors are available for various applications, such as the food industry, cooling areas, pharmacy, laboratories and clean rooms.



**FOR INTERNAL  
AND EXTERNAL  
USE**



**UP-TO-DATE  
SAFETY DEVICES  
INTEGRATED**



**AVAILABLE FOR  
COOLING AND  
FREEZING**

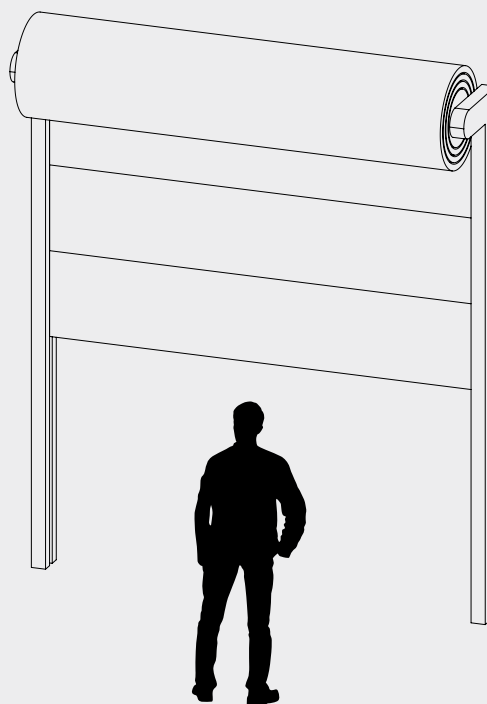

## CHARACTERISTICS

- ▶ Composite or aluminium anodised side guides.
- ▶ Wind proof Class 2 (up to 10 Beaufort / 120 km/hour).
- ▶ Bottom safety edge device by optical sensors.
- ▶ Fixed photocell protection on the daylight side (light curtain).
- ▶ Cover for roll and motor can be supplied.
- ▶ Frequency controlled door motor.

## OPERATION

- ▶ Pull cord switch.
- ▶ Remote control by receiver and transmitter.
- ▶ Radar movement detector.
- ▶ Loop detector.

# HOIST UP DOORS



**B**G Door is dealer of hoist up doors and can arrange installation, maintenance and after sales. The hoist-up doors consist of horizontal aluminium or steel profiles on which polyester fabric has been stretched on the inside and the outside. The horizontal profiles are guided in vertical rails, and are 100-1200 mm thick, depending on the door type and wind impact. The mega large hoist up doors can be sized up to 45 metres width and height as a standard version and available in various colours. Polyester hoisting belts are linked

to the crush-down protection. The stainless steel hoist protection is activated and checked on each opening and closing movement. The crush-down protection ensures that a closed door cannot be lifted manually (break-in).



VERY LARGE  
**OPENING UP TO 45 M**  
AS STANDARD



UP-TO-DATE  
**SAFETY DEVICES**  
INTEGRATED RESISTANT



TO  
**VERY HIGH**  
**WIND LOADS**

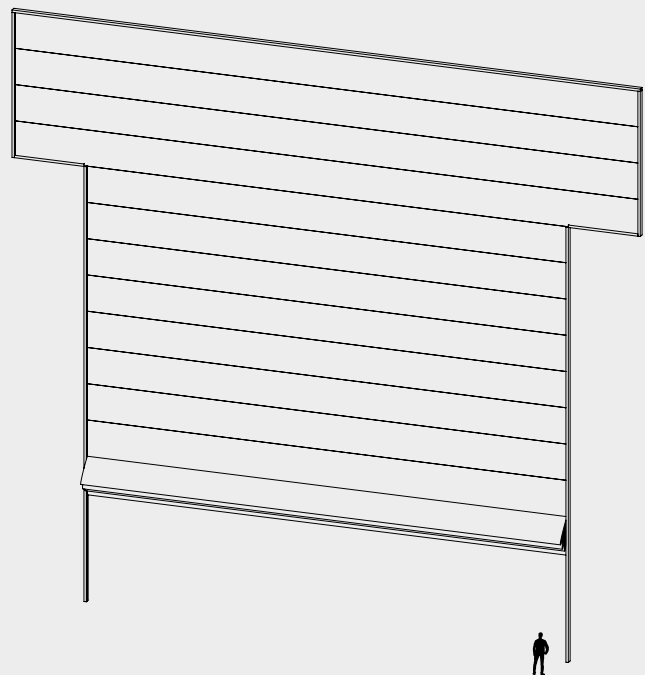

## CHARACTERISTICS

- ▶ Reinforced polyester fabric (weight 900 g/m<sup>2</sup>).
- ▶ Withstands temperatures from +70°C to -35°C.
- ▶ Flame-extinguishing in accordance with DIN 4102, B1/ SIS 650082, BS 5438.
- ▶ Tear resistance according to DIN 53356.
- ▶ Material is UV resistant and rot-proof.
- ▶ Noise reduction: 18 Db – 27 Db, depending on model.
- ▶ Wind impact 120 Km/h to 250 km/h (0.7 KN/m<sup>2</sup> - 3 Kn/m<sup>2</sup>), depending on model/version.
- ▶ Aluminium guide rails with brush profile for optimum sealing.
- ▶ Options are windows included in canvas, a translucent version, a special version for high-pressure jetting cabins and metal spraying plants and removal of central partitions.

# MOBILE PRECOOL UNIT



**O**ur Mobile Precool Unit allows you to cool down your (soft) fruit and vegetables rapidly down to the desired temperature. The movable precool unit uses the existing cool air from your own cold store. It distributes the cool air actively and efficiently through the product in the boxes. The unit can handle two rows of pallets up to a maximum of 24 pallets. The Mobile Precool Unit comes with a timer control and optional temperature sensor or air humidity sensor, both with display and set point. Besides cooling the Mobile Unit can be used for drying also.





REDUCTION OF  
**COOLING TIME**  
UP TO 75%



REDUCE WEIGHT LOSS  
AND EXTEND  
**SHELF LIFE**



MOVABLE BY  
**FORK LIFT**  
FOR FLEXIBILITY

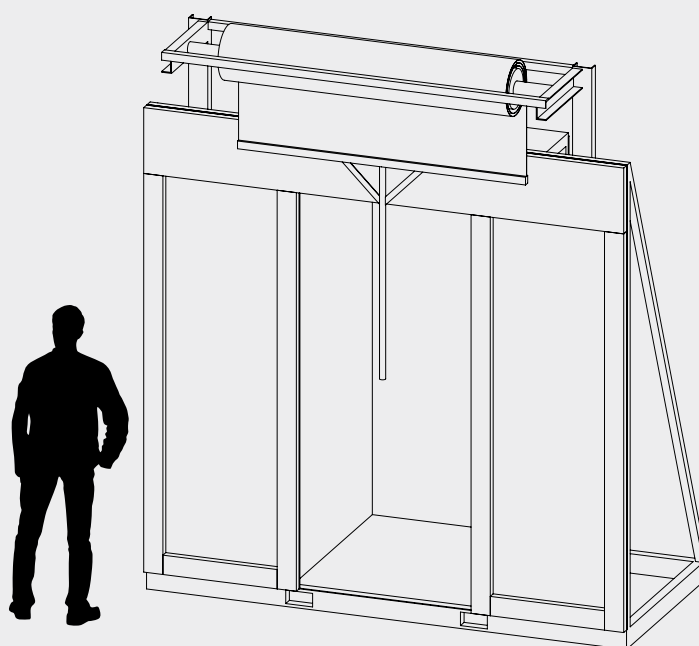

## CHARACTERISTICS

- ▶ Basic unit suitable for 2 pallets wide and 6 pallets deep, extension up to 2 x 12 pallets (full truck load).
- ▶ Operation: EC ventilator on/off including timer.
- ▶ Tarp including remote control with hand-held transmitter.
- ▶ Side cushion for pallets sealing.
- ▶ Your company logo or name on Tarp curtain (when required).

## TYPE MPU FQ20

<b>Capacity</b>	0-20.000 m <sup>3</sup> /h
<b>Rpm</b>	890
<b>Pressure</b>	160 Pa
<b>Power</b>	2.0 kW

## TYPE MPU EC20

<b>Capacity</b>	20.000 m <sup>3</sup> /h
<b>Rpm</b>	890
<b>Pressure</b>	140 Pa
<b>Power</b>	2.0 kW

Fruit Storage Ripening  
**ECOTOP START**



**E**cotop Start is a plug-and-play ripening unit, ready for use. It is pre-mounted and tested and includes an air cooler, heat pump (cooling and heating), control system, temperature sensor, manual operated tarp and gastight door. Suitable for all sorts of pallets, box types and part-loaded rooms. EcoTop Start offers a variety of benefits. This simple, flexible and economic construction boasts low energy consumption. Includes adjustable cooling capacity and adjustable airflow for high humidity ripening. Giving you maximum fruit quality at low ownership costs.



PRE-ASSEMBLED  
**PLUG-AND-PLAY**  
RIPENING SYSTEM



**NO REFRIGERATION**  
SYSTEM  
NECESSARY



FLEXIBLE AND  
**ECONOMICAL FOR**  
STARTING RIPENING

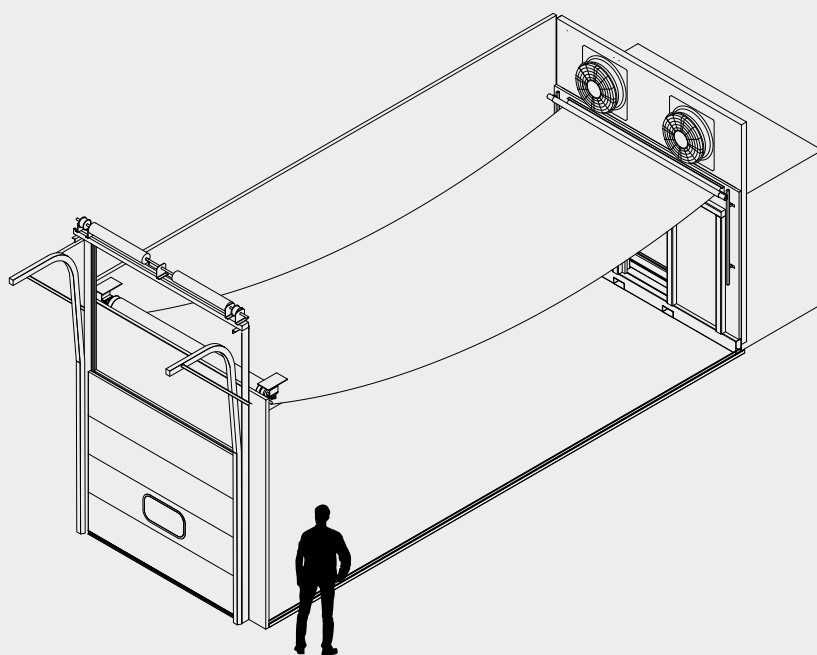

## CHARACTERISTICS

- ▶ Insulated panels: 60 mm.
- ▶ Fresh air ventilation: simply by opening the door.
- ▶ Prepared with a connector for an ethylene gas generator. The control system is prepared for immediate operation with ethylene gassing.
- ▶ Side-bumpers (recycled plastic) and illumination.
- ▶ Gas generator.
- ▶ Insulated panels.
- ▶ Online process control.

# Fruit Storage Ripening **TARP SYSTEMS**



**T**he Tarp is manufactured from Trevira fabric with PVC coating and has fibreglass reinforcement bars to resist air pressure. The Tarp is fixed onto the suction wall with special guide tracks and rollers for adjustment to different pallet heights. This pressure roller secures the Tarp to follow the pallets and guides it to cover the pallets completely airtight. We advise placing our integrated and depressible foam buffers (100x100) on the suction wall to prevent air by-pass behind the pallets.

#### **TARP RT** - Ripening Tarp track system.

Fitted with a manual movable roller pipe in a rails system, electrically operated by single-phase 220V tube motor easy to use by a personnel switch.

#### **TARP RF** - Ripening Tarp Fixed point system.

Fixed point with roller pipe on the ceiling of the room and electrically operated by 3-phase 400V/50Hz. Operator with fixed switch in front of the room.

#### **TARP PT** - Pre Cool Tarp track system.

Fitted with a manual movable roller pipe in a rails system, electrically operated by single-phase tube motor easy to operate using a personnel switch.



EASY TO USE  
**BY A PERSONNEL**  
SWITCH



**FIXED POINT**  
WITH ROLLER  
PIPE



ADJUSTABLE  
**TO DIFFERENT**  
PALLET HEIGHTS

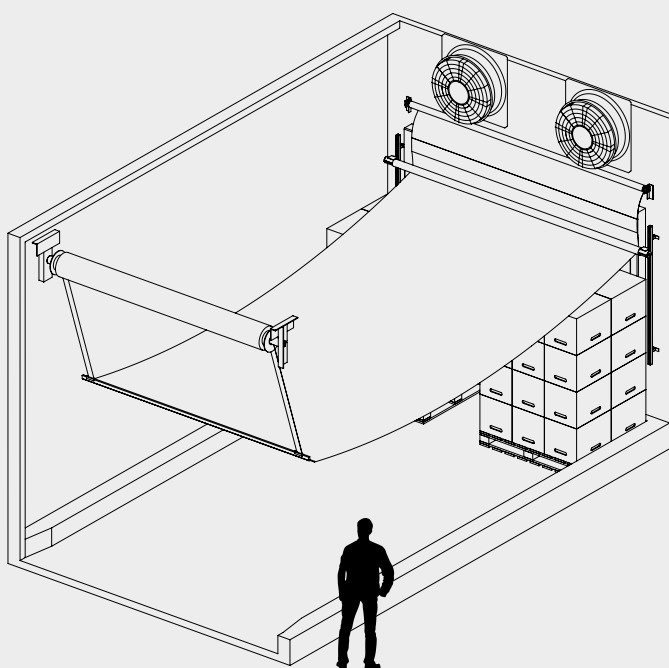

#### **TARP PF** - Pre Cool Fixed point system.

Fixed point with roller pipe at the ceiling of the room and electrically operated by single-phase tube motor. Operator with fixed switch in front of the room.

#### **TARP PB** - Pre Cool Box motor Fixed-point system.

Fixed point with roller pipe at the ceiling of the room and electrically operated by 3-phase 400V/50Hz. Operator with fixed switch in front of the room.

#### **TARP PW** - Pre Cool Wall installed system.

Wall installed with roller pipe and electrically operated single-phase 220V tube motor. Operated with supplied remote control and aluminium hand stick.

#### **CHARACTERISTICS**

##### **RIPENING**

- ▶ Curtain wide 3.000 mm.
- ▶ Foam buffers 4 vertical, 1 Horizontal.

##### **PRE COOLING**

- ▶ Curtain wide 1.500 mm.
- ▶ Foam buffers 2 vertical, 1 Horizontal.
- ▶ Tarp Type 1 we advise in case of many partial loads.

##### **TARP**

- ▶ PVC-coated fabric weight approx. 650 gr/m<sup>2</sup> with reinforcements of glass fibre tubes at every fixed mm to resist the pressure difference.

# CURTAINS AND FOAM BUFFERS



**F**or precooling and small quantity ripening we manufacture suction walls with foam buffers and special electrically operated curtain closures. Custom made for part loads and especially for various types of fruit and different sized pallets and boxes. These precool walls are also suitable for various other products that require rapid cooling. Due to the side-seal foam buffers and upper closure system by electrically or manually operated curtains, the cool airflow is guided over your product in the best and fastest way. The installation can be done in cooperation with your local refrigeration technicians.



SMALLER  
QUANTITIES



DIFFERENT  
PACKAGING



EASY ACCES  
TO PART  
LOADS

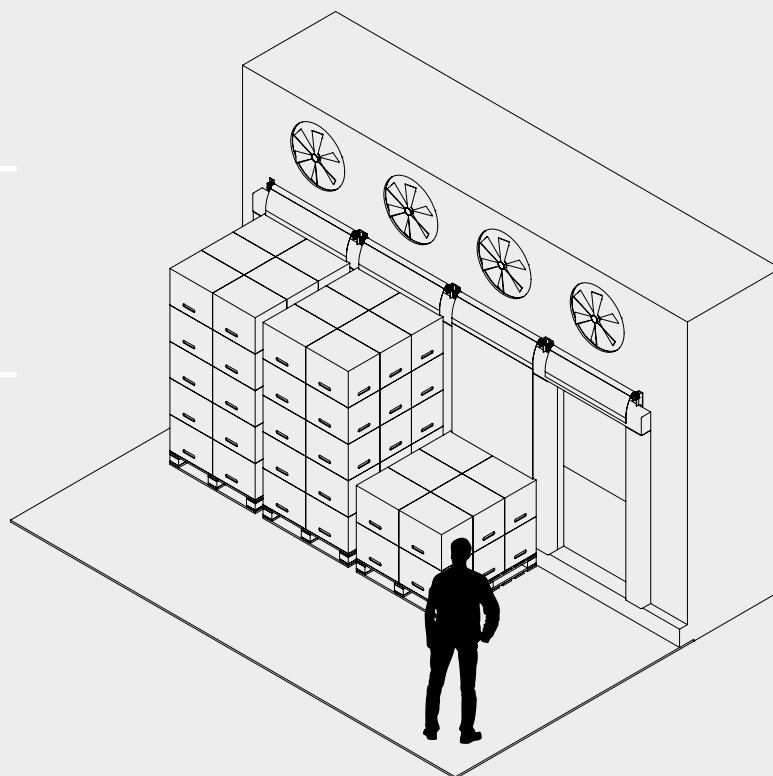

## CHARACTERISTICS

- ▶ Curtains electrically operated by 220 volt tube motor and wall push button.

## OPTION

- ▶ Manually operated curtains.
- ▶ Curtains PVC-coated fabric weight approx. 650 Gr/m<sup>2</sup>.
- ▶ Reinforcement by glass fibre tubes to resist pressure differences.
- ▶ Foam buffers thickness 50, 80 or 100 mm.
- ▶ Standard colours tarp and foam buffers:  
Ral 1003, 5002, 5005.



BRINGING  
**SPACES UNDER CONTROL.**



Zuideinde 44 - 52  
2991 LK, Barendrecht  
The Netherlands  
[www.bgdoor.com](http://www.bgdoor.com)