

INDAC₂

Industrial Air Curtain

Biddle



OPTIMAL CLIMATE SEPARATION

The Biddle IndAC₂ industrial air curtain, is the perfect solution for separating climates in industrial buildings. Doors are often open for long periods of time to facilitate transport in and out of the building. The IndAC₂ air curtain can be used for climate separation between indoor and outdoor environments and for indoor climate separation between two spaces with different temperatures.

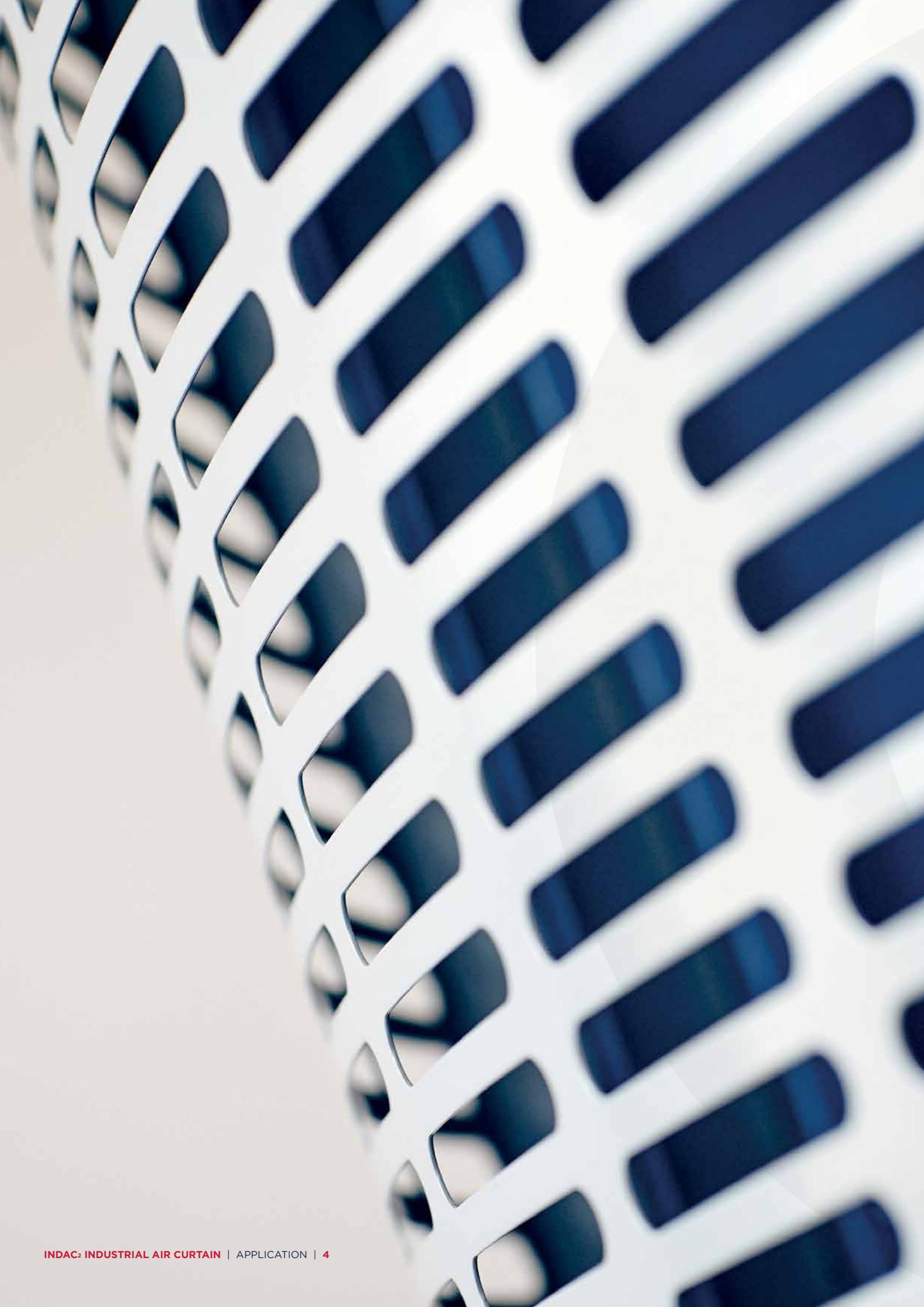

HIGH CLIMATE SEPARATION EFFICIENCY

Open doors cause energy loss and disturb the inside climate; the difference between the inside and outside temperature leads to an exchange of air, resulting in cold air entering and warm, heated air, flowing out. When the IndAC₂ air curtain is mounted above or next to an open door it provides a very efficient climate separation at the lowest energy consumption.

The comfort of staff operating near the door is improved by heating the cold incoming air through the air curtain, thus preventing draught. A corridor might seem like a relatively cheap option, but it can hinder traffic and make stock movements harder. An air curtain enables fast and safe logistics and saves energy at the same time, in turn providing a high return on investment.

By separating the outdoor climate from the indoor conditioned environment the IndAC₂ makes it possible to keep the door open whilst maintaining the indoor temperature.

FEATURES AND BENEFITS:

- Separation efficiency – rectifier technology
- Stable indoor climate - no draughts
- Comfortable working conditions
- Accessible entrance
- Safer and faster transport
- Maximum efficiency
- High performance stepless fans

ENERGY SAVING AND EFFICIENT

With the automatic control option fitted, the IndAC₂ continuously selects the correct settings. The automatic control in combination with stepless fans ensures that the settings are always set very precisely, which results in high separation efficiency and energy savings. Once the air curtain is installed and commissioned the user does not have to worry about the settings, as the output of the IndAC₂ will adjust to meet the challenges of the environment.

APPLICATIONS

The IndAC₂ air curtain is specifically designed for use in factories, warehouses, logistics centres and production areas but can also be used for internal climate separation in chill rooms or cold stores (ambient version) with a front hall or loading bay and in environments with a high ambient temperature.



HOW IT WORKS

With the automatic control option fitted, the IndAC₂ continuously selects the correct settings. Once the air curtain is installed and commissioned the user does not have to worry about the settings, as the output of the IndAC₂ will adjust to meet the challenges of the environment.

Sensors ensure that the IndAC₂ is supplied with all details regarding the climate outside and inside near the doorway. All the information is continuously translated by the CHIPS technology into the correct setting of the air curtain. The temperature and fan speed of the IndAC₂ are automatically adjusted, which means the unit is always operating at the desired setting. A constant, comfortable and energy efficient indoor climate is the result.

The desired room temperature is set by the user in the b-touch control panel **(1)**. The outside temperature sensor **(2)** measures the outdoor temperature. The fan speed of the air curtain is determined based on the set room temperature, the outside temperature and the door height. The air inlet temperature sensor **(4)** measures the actual room temperature. Based on this room temperature the discharge temperature is being calculated. If necessary, the fan speed is adjusted.

- ① B-touch
- ② Outside temperature sensor
- ③ Discharge temperature sensor
- ④ Air inlet temperature sensor
- ⑤ Door contact switch



IMPRESSIVE TECHNOLOGY CHIPS

With changing weather conditions and insufficient attention to or knowledge of an air curtain, it can be the case that an air curtain is not set up correctly. It can either blow too strong or too weak, with a discharge temperature that is too high or it is not switched on at all.

Energy loss is a result with low comfort (draught) and an unnecessarily high noise level. Biddle has developed the fully automatic and energy saving CHIPS-technology to save energy and provide a high level of comfort. The CHIPS-technology adjusts the discharge temperature and the strength of the air stream to the changing conditions around the doorway independent of each other. The technology has been translated into a fully automatic control for IndAC₂ industrial air curtain. The diagram below clarifies the operation of the CHIPS-technology in various conditions.

The situation in the middle is the optimal situation: Sufficient strength to reach the floor (optimum climate separation) and sufficient heat to warm incoming air to the indoor temperature required (comfort).

Due to the CHIPS-technology the IndAC₂ air curtain always functions in the correct speed and discharge temperature, with optimal energy savings as a result. The energy savings of the IndAC₂ with automatic control can increase by up to 75% compared to a manual controlled conventional air curtain.

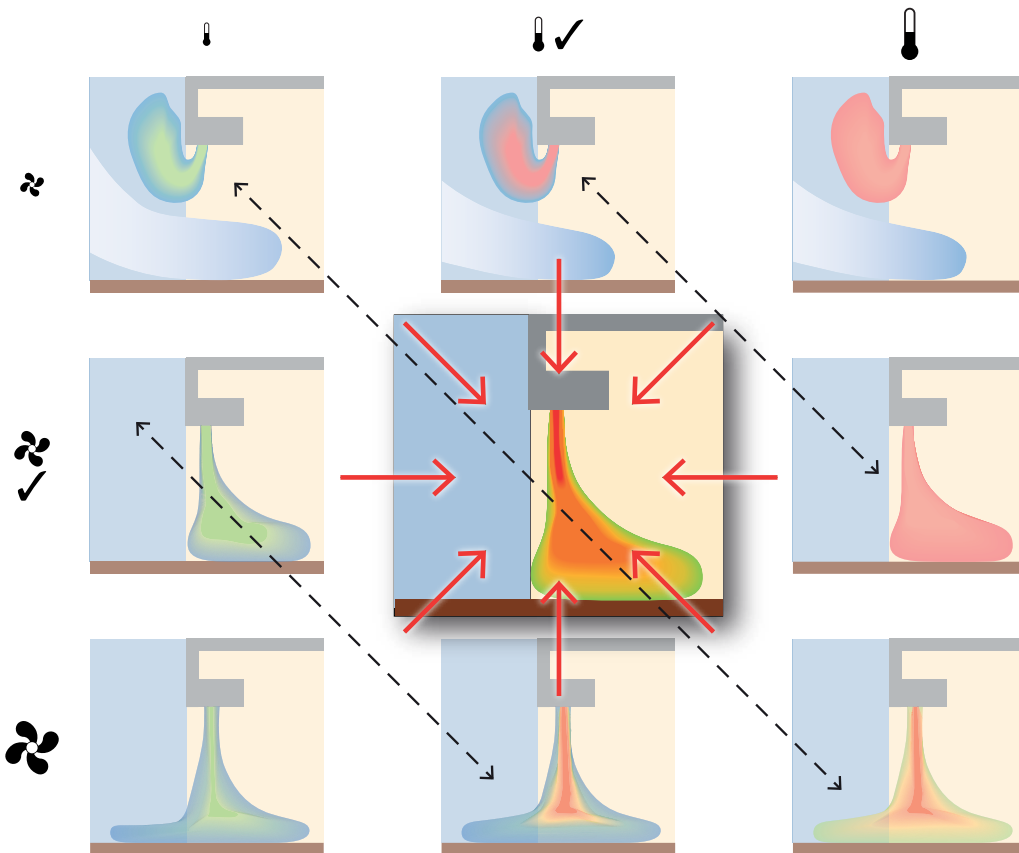

CHIPS



PATENTED DOUBLE RECTIFIER

Whilst developing the IndAC₂, Biddle chose to use the well known outlet discharge pattern, the Double Rectifier. The IndAC₂ is equipped with radial backward curved fans which homogeneously distribute the air across the whole discharge opening, producing high efficiency and comfort levels.

If a conventional industrial air curtain without a rectifier discharges air at the same velocity as a unit with a Double Rectifier, the downward penetration is tangibly less. The air stream does not reach the floor, and the open door is not covered off properly. Consequences include draught, loss of heat and comfort complaints.

The IndAC₂ makes sure the air, which is about to flow out through the open door, stays in the room. The Double Rectifier, which minimizes turbulence in the discharge air stream and surrounding air, ensures that the air movement generated by the fans, is directed downward in a deeply penetrating laminar air stream. As a consequence the energy consumption is reduced and comfort levels are increased all year round.

VARIOUS HEATING SOURCES

The IndAC₂ air curtain is suitable for connection to water or electric heating sources. An ambient model, without a heating battery, is also available. The versions with water coils and electric heating batteries are suitable for large industrial doorways to separate interior and outside temperature. Ambient models are suitable for climate separation in internal spaces for which no heated air stream is required.

CONTROLS

The IndAC₂ air curtain can come with a basic control option or the b-touch control.



Basic Control



b-touch Control Panel

ACCURATE STEPLESS CONTROL

The b-control is a 0-10V potentiometer that functions stepless and makes it easy to manually set the air curtain accurately to the desired fan speed. To be assured of the best possible climate separation the manual setting should be adjusted to circumstances several times a day.

AUTOMATIC ON AND OFF

Use of the optional door contact switch enables the IndAC₂ to be automatically switched on when the door opens and off when the door is closed.

ENERGY SAVING

The IndAC₂ is standard equipped with energy saving and high performance EC fans. These fans support the stepless operation of the b-control.

CONTROL OF MULTIPLE UNITS

With one b-control multiple units can be controlled. The IndAC₂ ST with b-control has the capacity to control a combination of units that cover a door width of max. 5 meters. The IndAC₂ MX with b-control has the capacity to control a combination of units that cover a door width of max. 7.5 meters.

B-TOUCH CONTROL

The fully automatic IndAC₂ comes with Biddle's touchscreen control panel: the b-touch. The simple menu structure of the b-touch makes it very easy to choose the desired settings using the clear preset menu. The IndAC₂ can be automatically set up using the intelligent software which is situated inside the air curtain. Usage and fault diagnostic data can be easily extracted via the b-touch data port. The data port also permits software updates, which means it is no longer necessary to open the unit for this. Extracting information from the air curtain can easily be achieved via the b-touch. Once set, the control panel is no longer necessary.

MODBUS COMMUNICATION

The IndAC₂ fitted with automatic control enables communication via Modbus from a remote PC or BMS system. If required b-touch and Modbus can be used in parallel allowing local and remote control of the air curtain.

MULTIPLE UNITS

When more units are connected, the b-touch control panel can control up to a max. of ten master units. One master unit and two slave units can be controlled simultaneously. In that case, only the master unit contains the intelligent software. The master unit can be connected to another master unit to which two slave units can also be connected.



A SOLUTION FOR EVERY SITUATION

COIL TYPES

H1	Water heating
	High water temperatures
	1 row element
H2	Water heating
	Low water temperatures
	2 row element
E	Electrical heating
	Only available with automatic control
	Only available in ST
A	Ambient, no heating coil
H1p	Water heating
	High water temperatures
	High pressure
	On customer order, always with welded flanges

CONTROL OPTIONS

- 🔴 Automatic control with b-touch control panel and CHIPS Technology
- 🔴 Basic control with b-control (0-10V)
- 🔴 BMS: Modbus communication (automatic control)

TYPES

The IndAC₂ is available in a standard (ST) and a maximal version (MX). The selection is based on the door heights.

- 🔴 IndAC₂ ST: 3-6m
- 🔴 IndAC₂ MX: 5-8m

LENGTHS

- 🔴 IndAC₂ ST: 150, 200 and 250cm
- 🔴 IndAC₂ MX: 150 and 225cm

MOUNTING

IndAC₂ air curtains in combination with an automatic control can be installed directly above the door. IndAC₂ with basic control can also be installed next to the door. Different installation positions are possible depending on the room layout around the door.

INSTALLATION

The available room layout around a door determines where and how an air curtain can be best installed. Thanks to a diverse range of installation positions, the IndAC₂ air curtain can be matched to the constructional possibilities offered by the local situation. Depending on the situation, the air curtain is either installed horizontally above or vertically next to the door, covering the full length or width of the doorway. For the vertical position there are two options: square to the wall and parallel to the wall. The unit should always be positioned as close to the door as possible. In case the situation does not allow a position close to the door, Biddle offers optional side shields. There are a total of five installation positions, which are shown below.

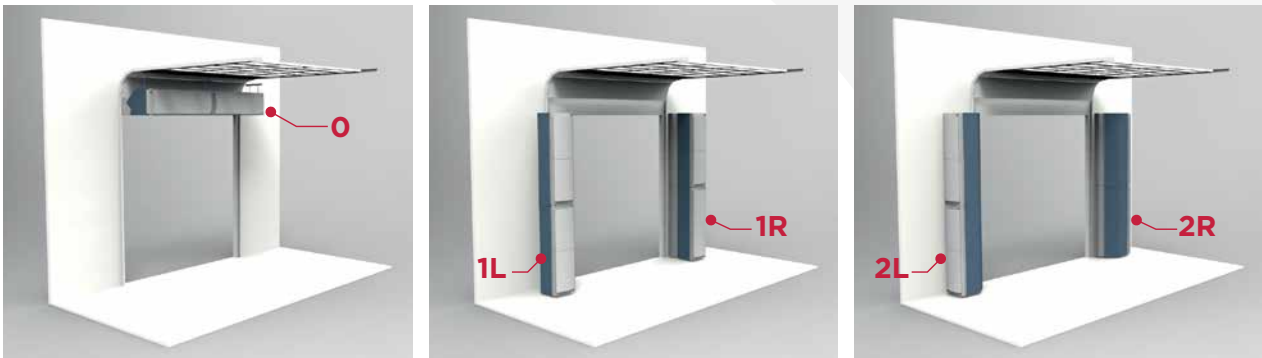

- 0** Horizontal, above door
- 1L** Vertical, left side, square to wall
- 1R** Vertical, right side, square to wall
- 2L** Vertical, left side, parallel to wall
- 2R** Vertical, right side, parallel to wall

MODULAR

The modular design of the IndAC₂ facilitates the installation of multiple devices next to or above each other, in order to cover all door heights or widths. The IndAC₂ ST with b-control can cover door widths of 5 meters. The IndAC₂ MX with b-control can cover door widths of 7.5 meters. With the automatic b-touch control maximal three units can be connected. For the exact amount of your specific type of air curtain, please contact your Biddle sales team who will be happy to develop a solution to suit you.

EASY TO MOUNT AND CLEAN

The various parts of the IndAC₂ are very easy to access, making it easy to install, maintain and clean. The unit contains a minimum of 'internal obstacles', resulting in a smooth air flow through the unit in which dust has little chance of collecting.

DESIGN

The IndAC₂ has a robust and modern design. With the pronounced industrial design of this air curtain, the appearance is consistent with the latest developments within the industry.

WHAT'S IN IT FOR ME?

STANDARD DELIVERY

- Two suspension brackets - for horizontal installation
- Two coupling plates - for vertical installation (only for basic unit)
- Wall bracket - for vertical installation (only for basic unit)

These components are also needed:

- Automatic control (b-touch) or basic control (b-control)
- Base plate / plinth (required for vertical installation)

Optional:

- Filter module (filter G4) for IndAC₂ ST
- Flanges
- Side shields

OPERATING PACKAGE

The unit can be supplied with a basic control or an automatic control. A corresponding operating package is supplied.



AUTOMATIC CONTROL

- b-touch touchscreen control panel
- Biddle control cable
- outdoor temperature sensor
- door contact switch
- water-side control (valve and actuator)
- room sensor for automatic CHIPS control (optional)



BASIC CONTROL

- b-control 0-10 V stepless fan controller
- door contact switch (optional)

ELECTRICAL CONNECTIONS

AUTOMATIC CONTROL

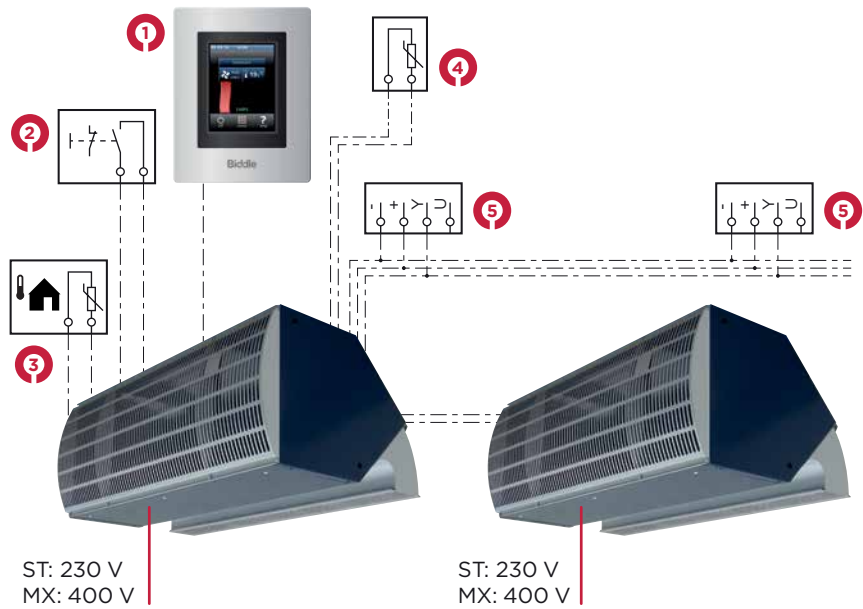

- 1 b-touch
- 2 Door switch
- 3 Outdoor sensor
- 4 Room sensor (optional)
- 5 Valve actuator

BASIC CONTROL

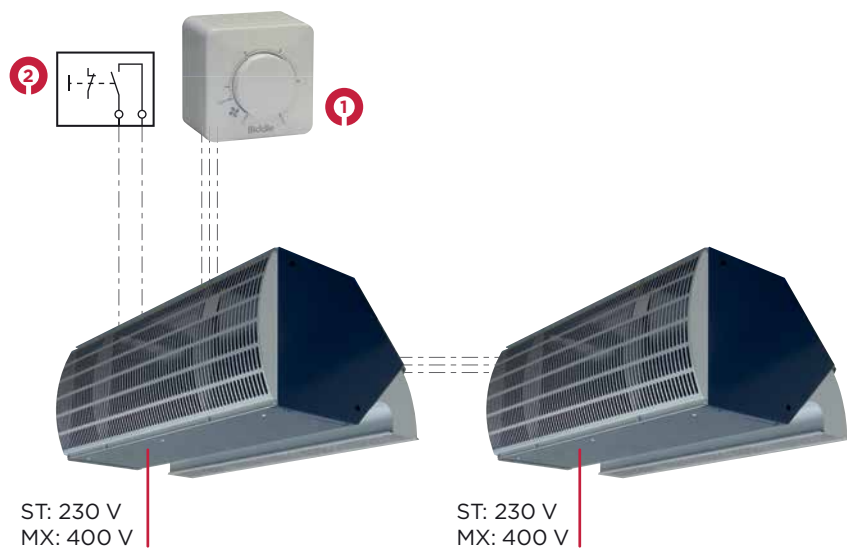

- 1 b-touch
- 2 Door switch (optional)

SPECIFICATIONS

CASING

The casing and the inlet grille are manufactured from zinc-plated sheet steel, strengthened to minimise deformations and vibrations, and have a full-polyester powder coating. The IndAC₂ is supplied in two colour combinations: RAL 5011/RAL 9006 and fully RAL 9006. Other colours are available on request.

MOTOR / FAN ASSEMBLY

The radial backward curved fans are mounted in the casing such that they cause no vibration. Each fan is driven by a rotor motor with EC technology. The fan casing are manufactured from aluminium and the impeller is made of plastic. The motor of the IndAC₂ is protected against overheating.

HEATING BATTERY

The heating battery LPHW is manufactured with 1/2" copper tubes and aluminium fins. The water connections are G1" female thread (except for IndAC₂ H1p). The maximum operating pressure is 16 bar at 120°C. The water connections of the H1p-battery have flanges. The maximum operating pressure is 23,8 bar at 175°C. The electric heating battery is manufactured with aluminium fins. The battery is controlled electronically and fitted with overload protection. When the device is switched off, the fans will continue to rotate until the fins have cooled sufficiently.

FORMULAS EXPLAINED

WATER FLOW RATE

When water and room temperatures other than the values represented in the tables are used, the water flow rate can be roughly calculated using the formula below. Before doing so, the heating capacity must first be recalculated based on the table with correction coefficients.

- m_w = water flow rate [l/h]
- Q = heating capacity [kW]
- C_{pw} = specific heat of water (=4.18) [kJ/kg°C]
- ΔT_w = water temperature differential [°C]
- ρ_w = density of water at 90°C (=0.984) [kg/l]

$$m_w = \frac{Q}{C_{pw} \Delta T_w \rho_w} 3600 \text{ [l/h]}$$

WATERSIDE PRESSURE LOSS

When water temperatures other than the values represented in the tables are used, the waterside pressure loss can be calculated using the formula below. To do so, the water flow rate must first be calculated.

- ΔP_{w1} = water pressure loss, table values [kPa]
- ΔP_{w2} = water pressure loss [kPa]
- m_{w1} = water flow rate table values [l/h]
- m_{w2} = water flow rate, calculated using formula [l/h]

$$\Delta P_{w2} = \Delta P_{w1} \left(\frac{m_{w2}}{m_{w1}} \right)^2 \text{ [kPa]}$$

SOUND

The sound data represented in the technical tables were measured at a distance of 5m from the device, in a room with a reverberation time of 0.8 seconds and with a volume of 2500m³. If a unit is used in a deviating room, or if multiple devices are used in a single room, the sound pressure level must be recalculated. This can be done using the below formula below.

- L_p = sound level [dB(A)]
- T = reverberation value in deviating room [s]
- T_o = reverberation value is 1.2s
- V = volume of deviating room [m³]
- V_o = volume of reference room [250m³]
- d = distance from the unit
- d_o = reference distance is 5m
- n = number of units

$$L_p = \text{table value} + \left(10 \log \left(\frac{T}{T_o} \right) - 10 \log \left(\frac{V}{V_o} \right) + 10 \log \left(\frac{d_o^2}{d^2} \right) + 10 \log (n) \right) \text{ [dB(A)]}$$

CORRECTION FACTORS

HEATING CAPACITY

IndAC₂ ST

Water range	Air inlet temperature									
	+5°C		+10°C		+15°C		+18°C		+20°C	
	H1	H2	H1	H2	H1	H2	H1	H2	H1	H2
120/100 °C	2.24 ¹	3.12 ¹	2.10 ¹	2.72 ¹	1.97 ¹	2.34 ¹	1.89 ¹	2.11 ¹	1.84 ¹	1.97 ¹
110/90 °C	2.00 ¹	3.12 ¹	1.87 ¹	2.72 ¹	1.74 ¹	2.34 ¹	1.66 ¹	2.11 ¹	1.61 ¹	1.97 ¹
100/80 °C	1.75	3.02 ¹	1.63	2.72 ¹	1.50	2.34 ¹	1.42	2.11 ¹	1.37	1.97 ¹
90/70 °C	1.50	2.62 ¹	1.38	2.41 ¹	1.25	2.20 ¹	1.18	2.08 ¹	1.13	1.97 ¹
82/71 °C	1.53	n/a	1.41	n/a	1.28	n/a	1.20	n/a	1.15	n/a
80/60 °C	1.25	2.21 ¹	1.12	2.00 ¹	1	1.80 ¹	0.93	1.68 ¹	0.88	1.60 ¹
70/50 °C	0.99	1.80	0.87	1.60	0.75	1.40	0.68	1.28	0.64	1.21
60/40 °C	0.74	1.39	0.62	1.19	0.51	1	0.44	0.88	0.39	0.81
50/40 °C	0.76	1.35	0.64	1.15	0.52	0.95	0.46	0.84	0.41	0.76

¹ Water range not suitable in case of an uncontrolled basic model.

- The discharge temperature of the IndAC₂ in combination with an automatic control is limited on 50°C.
- Inlet temperatures up to 120°C / 16 bar are only permitted if the water-side devices are tuned in to not exceed the maximum discharge temperature at the lowest fan setting.

IndAC₂ MX

Water range	Air inlet temperature									
	+5°C		+10°C		+15°C		+18°C		+20°C	
	H1	H2	H1	H2	H1	H2	H1	H2	H1	H2
120/100 °C	2.25 ¹	4.28 ¹	2.11 ¹	3.72 ¹	1.98 ¹	3.20 ¹	1.90 ¹	2.90 ¹	1.85 ¹	2.71 ¹
110/90 °C	2.01 ¹	3.87 ¹	1.87 ¹	3.61 ¹	1.74 ¹	3.20 ¹	1.67 ¹	2.90 ¹	1.61 ¹	2.71 ¹
100/80 °C	1.76	3.40 ¹	1.63	3.15 ¹	1.50	2.90 ¹	1.43	2.76 ¹	1.38	2.66 ¹
90/70 °C	1.51	2.91 ¹	1.38	2.67 ¹	1.25	2.43 ¹	1.18	2.29 ¹	1.13	2.19 ¹
82/71 °C	1.54	n/a	1.41	n/a	1.29	n/a	1.21	n/a	1.16	n/a
80/60 °C	1.25	2.42 ¹	1.12	2.19 ¹	1	1.95 ¹	0.93	1.81 ¹	0.88	1.72 ¹
70/50 °C	0.99	1.94	0.87	1.70	0.75	1.47	0.68	1.34	0.63	1.25
60/40 °C	0.73	1.45	0.62	1.22	0.50	1	0.43	0.87	0.39	0.78
50/40 °C	0.76	1.47	0.64	1.24	0.52	1.02	0.45	0.89	0.41	0.80

¹ Water range not suitable in case of an uncontrolled basic model.

- The discharge temperature of the IndAC₂ in combination with an automatic control is limited on 50°C.
- Inlet temperatures up to 120°C / 16 bar are only permitted if the water-side devices are tuned in to not exceed the maximum discharge temperature at the lowest fan setting.
- If circumstances differ from those described here, such as different water temperatures or more than one unit in a single room, please do not hesitate to ask for our advice.



INDAC₂

Technical Details



INDAC₂ ST-150-H1

Unit length	m	1.5				
Door width/height	m	3-6				
Electrical supply	V/ph/Hz	230/1/50				
Max. Input current	A	3				
Max. Input power	kW	0.52				
Max. Specific fan power	W/l/s	0.28				
Weight	kg	92				
Water range	°C	80/60				
Speed		2V	4V	6V	8V	10V
Air volume	m ³ /h	1506	3253	4937	6111	6738
Power consumption	kW	0.03	0.07	0.18	0.33	0.52
Air inlet temperature	°C	15				
Heating capacity	kW	13.3	21	26.2	29.2	30.6
Discharge air temperature	°C	40.8	33.8	30.5	28.9	28.3
Water flow rate	l/h	583	920	1150	1280	1342
Water pressure drop	kPa	0.4	1	1.5	1.8	2
Water pressure drop with 2 & 3-port valve	kPa	0.8	1.8	2.8	3.4	3.8
Sound pressure level at 5m	dB(A)	24	40	50	57	60

INDAC₂ ST-150-H2

Unit length	m	1.5				
Door width/height	m	3-6				
Electrical supply	V/ph/Hz	230/1/50				
Max. Input current	A	3				
Max. Input power	kW	0.52				
Max. Specific fan power	W/l/s	0.28				
Weight	kg	95				
Water range	°C	60/40				
Speed		2V	4V	6V	8V	10V
Air volume	m ³ /h	1506	3253	4937	6111	6738
Power consumption	kW	0.03	0.07	0.18	0.33	0.52
Air inlet temperature	°C	15				
Heating capacity	kW	14	23.1	29.3	32.9	34.6
Discharge air temperature	°C	42.2	35.7	32.3	30.7	30
Water flow rate	l/h	609	1003	1273	1427	1501
Water pressure drop	kPa	0.5	1.2	1.8	2.3	2.5
Water pressure drop with 2 & 3-port valve	kPa	0.8	2.2	3.4	4.3	4.7
Sound pressure level at 5m	dB(A)	24	40	50	57	60

INDAC₂ ST-200-H1

Unit length	m	2				
Door width/height	m	3-6				
Electrical supply	V/ph/Hz	230/1/50				
Max. Input current	A	4				
Max. Input power	kW	0.69				
Max. Specific fan power	W/l/s	0.28				
Weight	kg	118				
Water range	°C	80/60				
Speed		2V	4V	6V	8V	10V
Air volume	m ³ /h	2008	4337	6582	8148	8984
Power consumption	kW	0.03	0.1	0.23	0.44	0.69
Air inlet temperature	°C	15				
Heating capacity	kW	18.9	30.1	37.9	42.3	44.4
Discharge air temperature	°C	42.5	35.3	31.8	30.1	29.4
Water flow rate	l/h	829	1321	1660	1853	1945
Water pressure drop	kPa	0.9	2.2	3.4	4.2	4.5
Water pressure drop with 2 & 3-port valve	kPa	1.6	4	6.1	7.6	8.3
Sound pressure level at 5m	dB(A)	25	41	51	58	61

INDAC₂ ST-200-H2

Unit length	m	2				
Door width/height	m	3-6				
Electrical supply	V/ph/Hz	230/1/50				
Max. Input current	A	4				
Max. Input power	kW	0.69				
Max. Specific fan power	W/l/s	0.28				
Weight	kg	123				
Water range	°C	60/40				
Speed		2V	4V	6V	8V	10V
Air volume	m ³ /h	2008	4337	6582	8148	8984
Power consumption	kW	0.03	0.1	0.23	0.44	0.69
Air inlet temperature	°C	15				
Heating capacity	kW	20.1	33.5	42.9	48.3	50.8
Discharge air temperature	°C	44.2	37.6	34	32.3	31.5
Water flow rate	l/h	871	1455	1862	2094	2206
Water pressure drop	kPa	1	2.7	4.2	5.3	5.8
Water pressure drop with 2 & 3-port valve	kPa	1.8	4.8	7.7	9.7	10.7
Sound pressure level at 5m	dB(A)	25	41	51	58	61

INDAC₂ ST-250-H1

Unit length	m	2.5				
Door width/height	m	3-6				
Electrical supply	V/ph/Hz	230/1/50				
Max. Input current	A	5				
Max. Input power	kW	0.87				
Max. Specific fan power	W/l/s	0.28				
Weight	kg	144				
Water range	°C	80/60				
Speed		2V	4V	6V	8V	10V
Air volume	m ³ /h	2510	5421	8227	10185	11230
Power consumption	kW	0.04	0.12	0.29	0.55	0.87
Air inlet temperature	°C	15				
Heating capacity	kW	24.5	39.3	49.6	55.4	58.2
Discharge air temperature	°C	43.5	36.2	32.6	30.9	30.1
Water flow rate	l/h	1076	1724	2172	2429	2551
Water pressure drop	kPa	1.7	4.1	6.3	7.8	8.5
Water pressure drop with 2 & 3-port valve	kPa	2.9	7.1	11	13.7	15
Sound pressure level at 5m	dB(A)	26	42	52	59	62

INDAC₂ ST-250-H2

Unit length	m	2.5				
Door width/height	m	3-6				
Electrical supply	V/ph/Hz	230/1/50				
Max. Input current	A	5				
Max. Input power	kW	0.87				
Max. Specific fan power	W/l/s	0.28				
Weight	kg	150				
Water range	°C	60/40				
Speed		2V	4V	6V	8V	10V
Air volume	m ³ /h	2510	5421	8227	10185	11230
Power consumption	kW	0.04	0.12	0.29	0.55	0.87
Air inlet temperature	°C	15				
Heating capacity	kW	26.1	44	56.6	63.7	67.2
Discharge air temperature	°C	45.3	38.7	35.1	33.3	32.5
Water flow rate	l/h	1132	1909	2453	2765	2915
Water pressure drop	kPa	1.9	5	8	10	11
Water pressure drop with 2 & 3-port valve	kPa	3.2	8.7	14	17.6	19.5
Sound pressure level at 5m	dB(A)	26	42	52	59	62

INDAC₂ MX-150-H1

Unit length	m	1.5				
Door width/height	m	5-8				
Electrical supply	V/ph/Hz	400/3/50				
Max. Input current	A	3.1				
Max. Input power	kW	1.8				
Max. Specific fan power	W/l/s	0.45				
Weight	kg	201				
Water range	°C	80/60				
Speed		2V	4V	6V	8V	10V
Air volume	m ³ /h	3198	6613	9809	12231	14356
Power consumption	kW	0.07	0.24	0.61	1.22	1.8
Air inlet temperature	°C	15				
Heating capacity	kW	24.7	37.2	45.5	50.7	54.6
Discharge air temperature	°C	37.5	31.4	28.5	27.1	26.1
Water flow rate	l/h	1081	1631	1995	2220	2394
Water pressure drop	kPa	0.5	1	1.4	1.8	2
Water pressure drop with 2 & 3-port valve	kPa	0.6	1.4	2.1	2.5	2.9
Sound pressure level at 5m	dB(A)	38	49	59	66	69

INDAC₂ MX-150-H2

Unit length	m	1.5				
Door width/height	m	5-8				
Electrical supply	V/ph/Hz	400/3/50				
Max. Input current	A	3.1				
Max. Input power	kW	1.8				
Max. Specific fan power	W/l/s	0.45				
Weight	kg	207				
Water range	°C	60/40				
Speed		2V	4V	6V	8V	10V
Air volume	m ³ /h	3198	6613	9809	12231	14356
Power consumption	kW	0.07	0.24	0.61	1.22	1.8
Air inlet temperature	°C	15				
Heating capacity	kW	23.8	36.4	44.7	49.8	53.8
Discharge air temperature	°C	36.7	31.1	28.3	26.9	25.9
Water flow rate	l/h	1031	1580	1939	2162	2334
Water pressure drop	kPa	0.3	0.6	0.8	1	1.2
Water pressure drop with 2 & 3-port valve	kPa	0.4	1	1.5	1.8	2.1
Sound pressure level at 5m	dB(A)	38	49	59	66	69

INDAC₂ MX-225-H1

Unit length	m	2.25				
Door width/height	m	5-8				
Electrical supply	V/ph/Hz	400/3/50				
Max. Input current	A	4.6				
Max. Input power	kW	2.7				
Max. Specific fan power	W/l/s	0.45				
Weight	kg	277				
Water range	°C	80/60				
Speed		2V	4V	6V	8V	10V
Air volume	m ³ /h	4797	9919	14713	18347	21534
Power consumption	kW	0.11	0.36	0.91	1.83	2.7
Air inlet temperature	°C	15				
Heating capacity	kW	40.5	61.9	76.2	85	91.9
Discharge air temperature	°C	39.6	33.2	30.1	28.5	27.5
Water flow rate	l/h	1776	2713	3339	3727	4028
Water pressure drop	kPa	1.5	3.3	4.9	6	6.9
Water pressure drop with 2 & 3-port valve	kPa	2	4.5	6.7	8.2	9.5
Sound pressure level at 5m	dB(A)	40	50	60	67	70

INDAC₂ MX-225-H2

Unit length	m	2.25				
Door width/height	m	5-8				
Electrical supply	V/ph/Hz	400/3/50				
Max. Input current	A	4.6				
Max. Input power	kW	2.7				
Max. Specific fan power	W/l/s	0.45				
Weight	kg	286				
Water range	°C	60/40				
Speed		2V	4V	6V	8V	10V
Air volume	m ³ /h	4797	9919	14713	18347	21534
Power consumption	kW	0.11	0.36	0.91	1.83	2.7
Air inlet temperature	°C	15				
Heating capacity	kW	41.1	64.5	80.1	89.8	97.4
Discharge air temperature	°C	40	34	30.9	29.3	28.2
Water flow rate	l/h	1783	2798	3476	3898	4227
Water pressure drop	kPa	0.8	1.9	2.9	3.6	4.2
Water pressure drop with 2 & 3-port valve	kPa	1.3	3.2	4.8	6	7
Sound pressure level at 5m	dB(A)	40	50	60	67	70

INDAC₂ ST-150-E

Unit length	m	1.5				
Door width/height	m	3-6				
Electrical supply motor and controller	V/ph/Hz	230/1/50				
Electrical supply E module	V/ph/Hz	400/3/50				
Max. Input current	A	3				
Max. Current consumption (3 phase)	A	67.6				
Max. Input power	kW	0.52				
Max. Power consumption, heating	kW	46.8				
Max. Specific fan power	W/l/s	0.28				
Weight	kg	119				
Speed		2V	4V	6V	8V	10V
Air volume	m ³ /h	1506	3253	4937	6111	6738
Air inlet temperature	°C	15				
Heating capacity	kW	14.8	22.2	29.6	37.1	44.5
Discharge air temperature	°C	44.4	35.4	33	33.1	34.7
Sound pressure level at 5m	dB(A)	24	40	50	57	60

INDAC₂ ST-200-E

Unit length	m	2				
Door width/height	m	3-6				
Electrical supply motor and controller	V/ph/Hz	230/1/50				
Electrical supply E module	V/ph/Hz	400/3/50				
Max. Input current	A	4				
Max. Current consumption (3 phase)	A	91				
Max. Input power	kW	0.69				
Max. Power consumption, heating	kW	63				
Max. Specific fan power	W/l/s	0.28				
Weight	kg	154				
Speed		2V	4V	6V	8V	10V
Air volume	m ³ /h	2008	4337	6582	8148	8984
Air inlet temperature	°C	15				
Heating capacity	kW	20	29.9	39.9	49.9	59.9
Discharge air temperature	°C	44.7	35.6	33.1	33.3	34.9
Sound pressure level at 5m	dB(A)	25	41	51	58	61

INDAC₂ ST-150-A

Unit length	m	1.5				
Door width/height	m	3-6				
Electrical supply	V/ph/Hz	230/1/50				
Max. Input current	A	3				
Max. Input power	kW	0.52				
Max. Specific fan power	W/l/s	0.28				
Weight	kg	78				
Speed		2V	4V	6V	8V	10V
Air volume	m ³ /h	1506	3253	4937	6111	6738
Power consumption	kW	0.03	0.07	0.18	0.33	0.52
Sound pressure level at 5m	dB(A)	24	40	50	57	60

INDAC₂ ST-200-A

Unit length	m	2				
Door width/height	m	3-6				
Electrical supply	V/ph/Hz	230/1/50				
Max. Input current	A	4				
Max. Input power	kW	0.69				
Max. Specific fan power	W/l/s	0.28				
Weight	kg	100				
Speed		2V	4V	6V	8V	10V
Air volume	m ³ /h	2008	4337	6582	8148	8984
Power consumption	kW	0.03	0.1	0.23	0.44	0.69
Sound pressure level at 5m	dB(A)	25	41	51	58	61

INDAC₂ ST-250-A

Unit length	m	2.5				
Door width/height	m	3-6				
Electrical supply	V/ph/Hz	230/1/50				
Max. Input current	A	5				
Max. Input power	kW	0.87				
Max. Specific fan power	W/l/s	0.28				
Weight	kg	123				
Speed		2V	4V	6V	8V	10V
Air volume	m ³ /h	2510	5421	8227	10185	11230
Power consumption	kW	0.04	0.12	0.29	0.55	0.87
Sound pressure level at 5m	dB(A)	26	42	52	59	62

INDAC₂ MX-150-A

Unit length	m	1.5				
Door width/height	m	5-8				
Electrical supply	V/ph/Hz	400/3/50				
Max. Input current	A	3.1				
Max. Input power	kW	1.8				
Max. Specific fan power	W/l/s	0.45				
Weight	kg	190				
Speed		2V	4V	6V	8V	10V
Air volume	m ³ /h	3198	6613	9809	12231	14356
Power consumption	kW	0.07	0.24	0.61	1.22	1.8
Sound pressure level at 5m	dB(A)	38	49	59	66	69

INDAC₂ MX-225-A

Unit length	m	2.25				
Door width/height	m	5-8				
Electrical supply	V/ph/Hz	400/3/50				
Max. Input current	A	4.6				
Max. Input power	kW	2.7				
Max. Specific fan power	W/l/s	0.45				
Weight	kg	249				
Speed		2V	4V	6V	8V	10V
Air volume	m ³ /h	4797	9919	14713	18347	21534
Power consumption	kW	0.11	0.36	0.91	1.83	2.7
Sound pressure level at 5m	dB(A)	40	50	60	67	70

INSTALLATION POSITION 0, 1L AND 1R

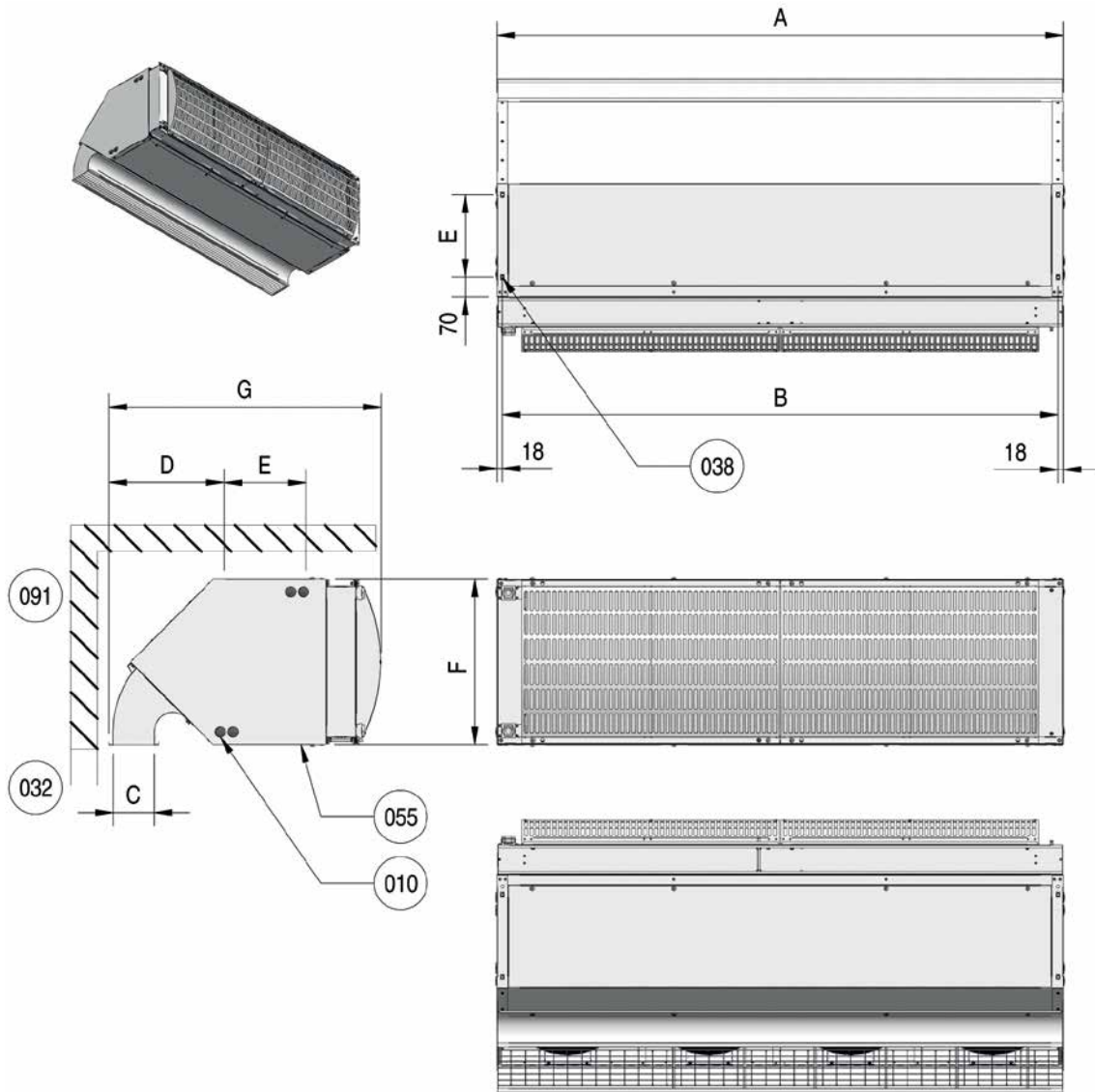

							☄	💧	⚡	☄	💧
										+ 041	+ 041
	A	B	C	D	E	F	G	G	G	G	G
IndAC ₂ ST 155-..	1500	1464					853	956	976	976	1079
IndAC ₂ ST 200-..	2000	1964	146	407	290	583	853	956	976	976	1079
IndAC ₂ ST 250-..	2500	2464									
IndAC ₂ MX 150-..	1500	1464									
IndAC ₂ MX 225-..	2250	2214	209	547	450	808	1193	1316	-	-	-

INDEX

The corresponding numbers in the water connections sketch are explained below:

10-Cable feed through. **32**-Door **38**-Female thread for suspension/fixation M12 (4x).

41-Filter module. **55**-Inspection panel. **91**-Wall. **64**-Return. **81**-Supply.

INSTALLATION POSITION 2L AND 2R

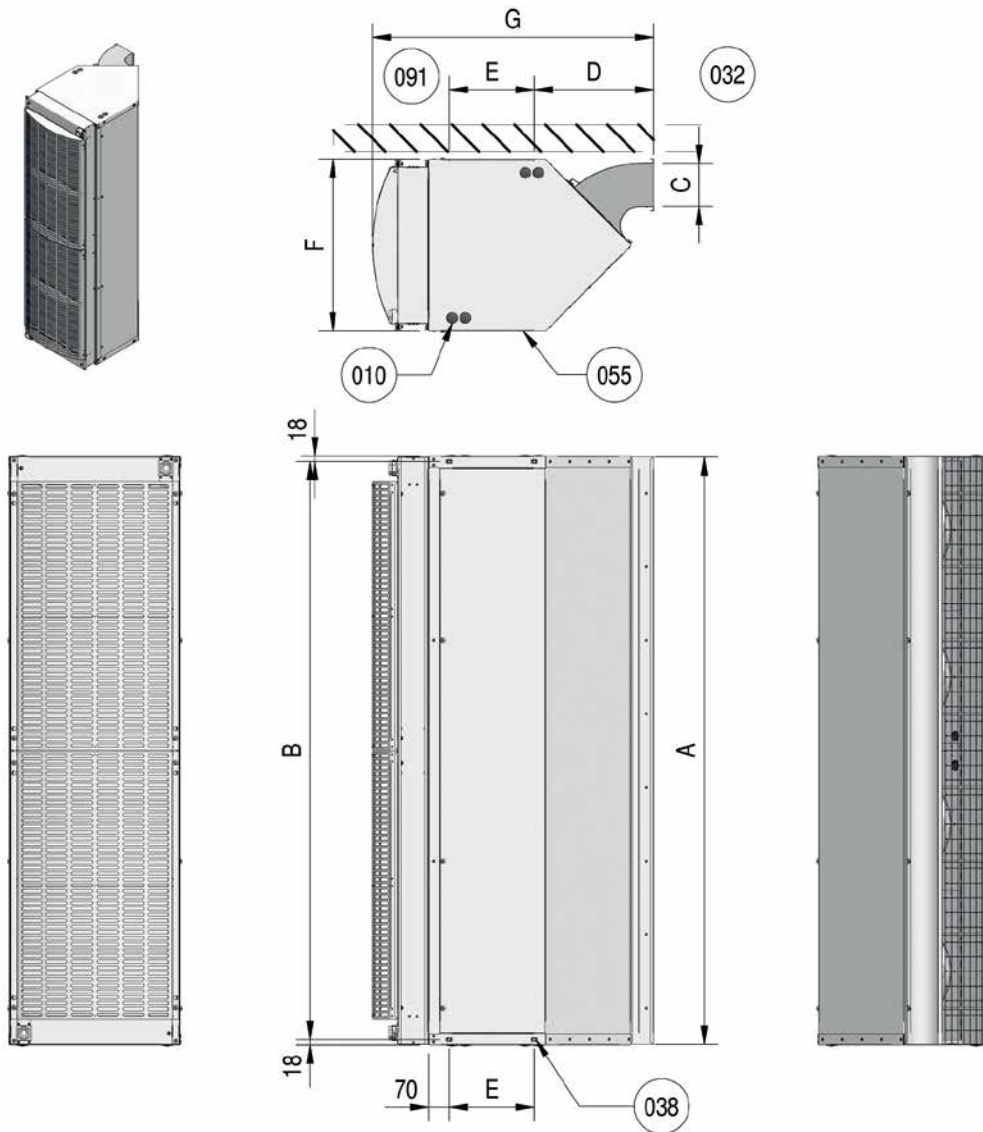

							☄	💧	⚡	☄	💧
										+ 041	+ 041
	A	B	C	D	E	F	G	G	G	G	G
IndAC ₂ ST 155-..	1500	1464									
IndAC ₂ ST 200-..	2000	1964	146	407	290	583	853	956	976	976	1079
IndAC ₂ ST 250-..	2500	2464									
IndAC ₂ MX 150-..	1500	1464									
IndAC ₂ MX 225-..	2250	2214	209	547	450	808	1193	1316	-	-	-

INDEX

The corresponding numbers in the water connections sketch are explained below:
10-Cable feed through. **32**-Door **38**-Female thread for suspension/fixation M12 (4x).
41-Filter module. **55**-Inspection panel. **91**-Wall. **64**-Return. **81**-Supply.

WATER CONNECTIONS

ST-...-H1-0
MX-...-H1/H2-0

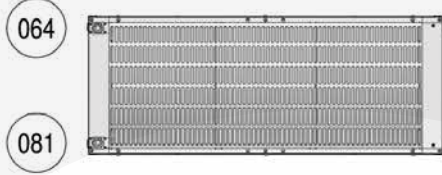

ST-...-H2-0

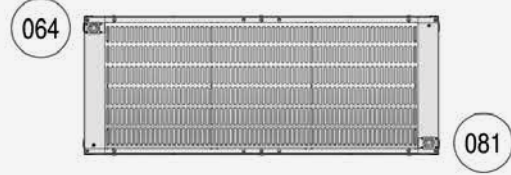

ST-...-H1-1L
ST-...-H1-2L
MX-...-H1/H2-1L
MX-...-H1/H2-2L

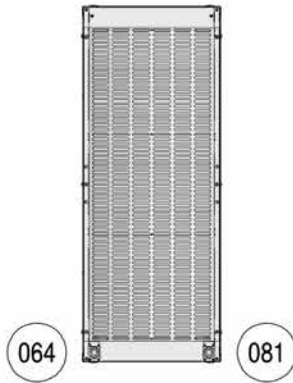

ST-...-H1-1R
ST-...-H1-2R
MX-...-H1/H2-1R
MX-...-H1/H2-2R

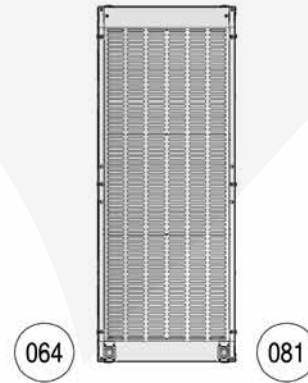

ST-...-H2-1L
ST-...-H2-2L

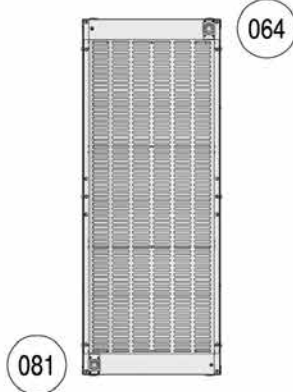

ST-...-H2-1R
ST-...-H2-2R

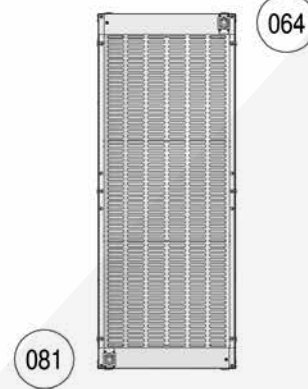

STANDARD

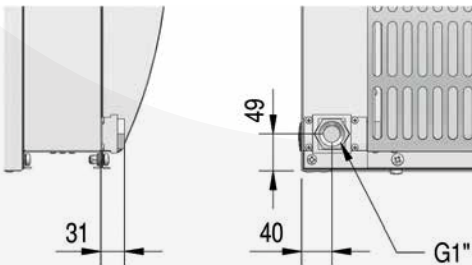

ACCESSORY SET

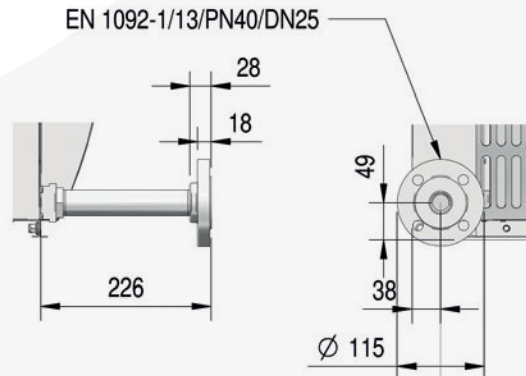

INDEX

The corresponding numbers in the water connections sketch are explained below:
10-Cable feed through. **32**-Door **38**-Female thread for suspension/fixation M12 (4x).
41-Filter module. **55**-Inspection panel. **91**-Wall. **64**-Return. **81**-Supply.

BIDDLE AIR SYSTEMS

St. Mary's Road
Nuneaton
Warwickshire
CV11 5AU

T +44 (0) 2476 384 233

E sales@biddle-air.co.uk

www.biddle-air.co.uk



Biddle

Every effort has been made to ensure descriptions are correct at the time of print.
Errors and omissions excepted. INDAC2|V1|11|2019